

Motor SCM 012-130

SAE



Sunfab SCM is a range of robust axial piston motors especially suitable for mobile hydraulics.

Sunfab SCM is of the bent-axis type with spherical pistons. The design results in a compact motor with few moving parts, high starting torque and high reliability.

The SCM covers the entire displacement range 12-130 cm³/rev at a maximum working pressure of 40 MPa.

SUNFAB SCM combines a tapered roller bearing and a radial bearing for high radial load tolerance and long life time.

Sunfab SCM's high level of reliability is based on the choice of materials, hardening methods, surface structures and the quality assured manufacturing process.

Type		012 SAE B	017 SAE B	025 SAE B	034 SAE B	047 SAE C	064 SAE C	084		108		130 SAE D
								SAE C	SAE D	SAE C	SAE D	
Displacement	cm ³ /rev.	12.6	17.0	25.4	34.2	47.1	63.5	83.6	83.6	108.0	108.0	130.0
Working pressure	MPa	40	40	40	40	40	40	40	40	40	40	35
	MPa	35	35	35	35	35	35	35	35	35	35	30
Revolutions	rpm	8250	8250	6500	6500	5900	5900	4800	4600	4800	4600	4600
	rpm	7500	7500	5900	5900	5300	5300	4400	4200	4400	4200	4200
	rpm	300	300	300	300	300	300	300	300	300	300	300
Power	kW	50	70	80	110	135	180	200	190	255	245	255
	kW	20	25	40	55	65	90	100	100	130	130	135
Start torque theoretical value	Nm/MPa	2.0	2.7	4.0	5.4	7.5	10.0	13.3	13.3	17.1	17.1	20.5
Mass moment of inertia (x 10 ⁻³)	kg m ²	0.9	0.9	1.1	1.1	2.6	2.6	6.3	7.4	6.3	7.4	7.4
Weight	kg	9.0	9.0	9.0	9.0	15.0	15.0	18.0	35.0	18.0	35.0	35.0

Data concerning RPM are based on maximum permitted peripheral velocity of the tapered roller bearing.

Intermittent power data are based on maximum continuous speed and maximum working pressure.

Continuous power data are based on maximum output power without external cooling of the motor housing.

Intermittent duty is defined as follows: max 6 seconds per minute, e.g. peak RPM when unloading or accelerating.

Versions, main data

Example

M-084 W/N-C4 S / F

Type:

M Motor with fixed displacement

Size:

012 Displacement cm³/rev.

017

025

034

047

064

084

108

130

Direction of rotation:

W Independent

Shaft seal:

N Nitrile

H Nitrile, high pressure

V Viton, high temperature

Connections:

U UN thread

G ISO G thread

F Flange (SAE J518 code 62)

Type of shaft:

S Spline shaft (SAE J498b)

13T 16/32 30° CLASS 5

14T 12/24 30° CLASS 5

13T 8/16 30° CLASS 5

K Key shaft (SAE J744)

Ø25.4

Ø31.7

Ø44.45

Mounting flange:

B4 SAE B (SAE J744)

C4 SAE C (SAE J744)

D4 SAE D (SAE J744)

SCM 012-034

SCM 012-034

SCM 047-130

SCM 012-034 SAE B

SCM 047-108 SAE C

SCM 084-130 SAE D

SCM 012-034 SAE B

SCM 047-108 SAE C

SCM 084-130 SAE D

SCM 012-034 SAE B

SCM 047-108 SAE C

SCM 084-130 SAE D

Choice of shaft seal

Motor SCM	Code	Temp. °C	Max. housing pressure MPa at rpm					
			1000	1500	2000	3000	4000	5000
012-034 B	N	75	0.64	0.42	0.32	0.21	0.16	0.12
	H	75	2.87	1.91	1.43	0.96	0.72	0.52
	V	90	0.64	0.42	0.32	0.21	0.16	0.12
047-108 C	N	75	0.55	0.36	0.27	0.18	0.14	0.11
	H	75	2.46	1.64	1.23	0.82	0.61	0.51
	V	90	0.55	0.36	0.27	0.18	0.14	0.11
084-130 D	N	75	0.35	0.23	0.17	0.12		
	H	75	1.56	1.04	0.78	0.52		
	V	90	0.35	0.23	0.17	0.12		

Subject to design modifications without notice

Factors affecting the choice of shaft seal include the hydraulic motor housing pressure and the drainage oil temperature.

Code according to Versions, main data.

The drainage oil should have a maximum temperature of 75 °C with a Nitrile shaft seal and 90 °C with a Viton shaft seal. These temperatures must not be exceeded.

Dimensions

SCM 012-034 SAE B

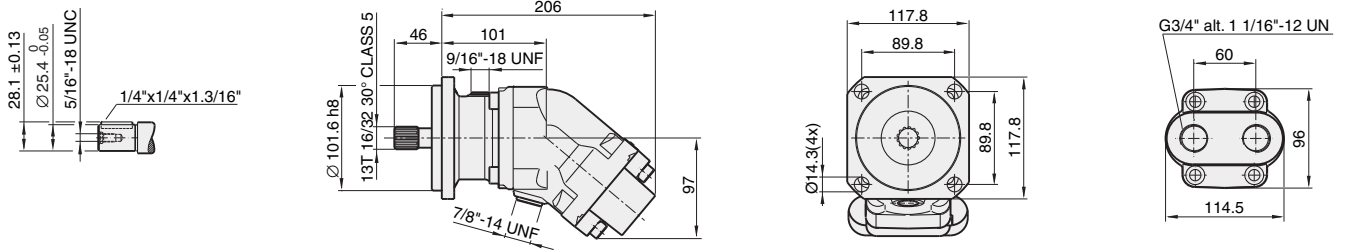

SCM 047-064 SAE C

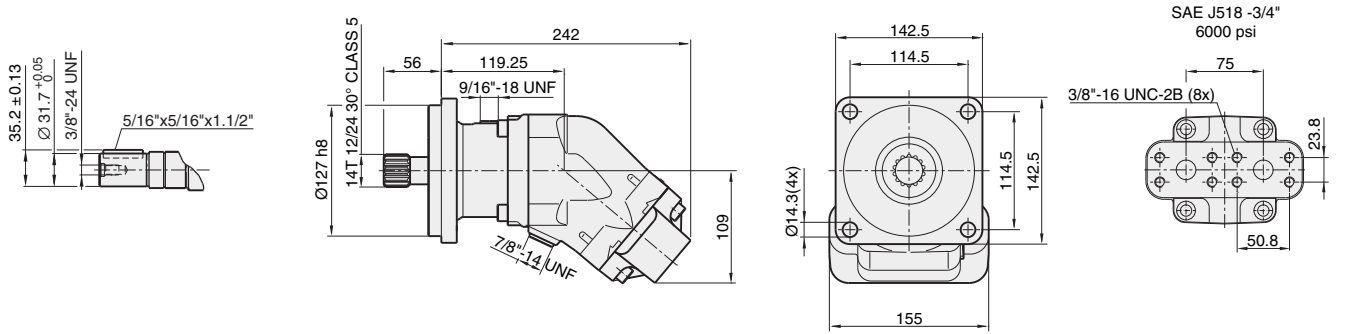

SCM 084-108 SAE C



SCM 084-130 SAE D

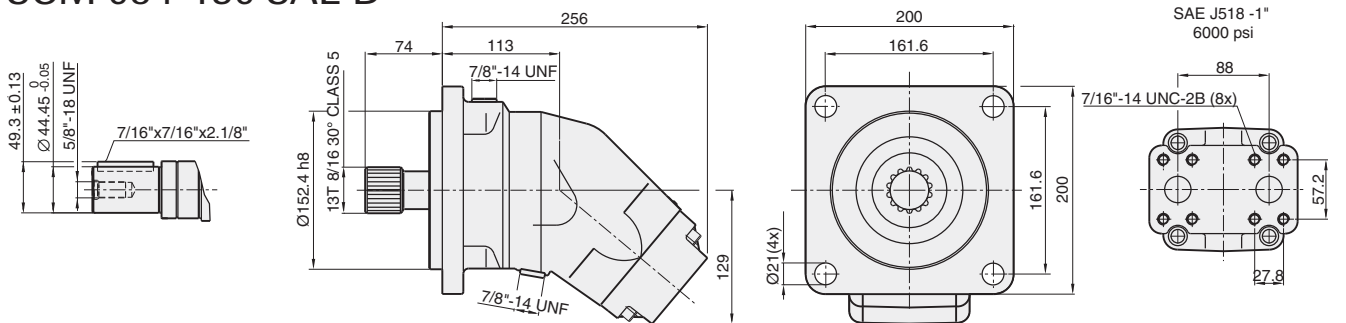

General instructions

Shaft loads

The life of the motor is highly dependent on the bearing life.

The bearings are affected by operation conditions such as speed, pressure, oil viscosity and filtration. External load on the shaft, as well as its size, direction and location also affect the bearing life.

For calculation of bearing life in special applications, please contact Sunfab Hydraulics.

Optimal force direction of radial load

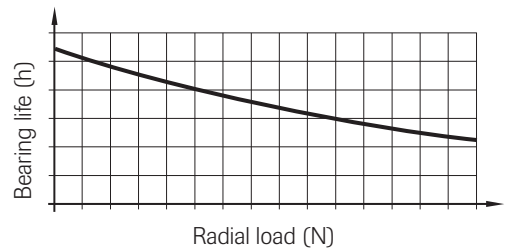
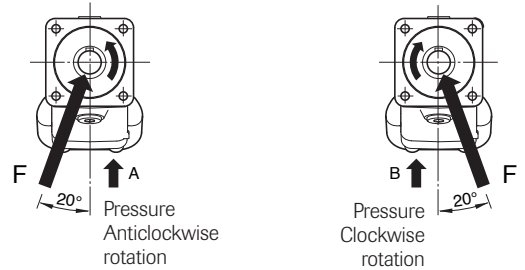

Installation

The motor housing should be filled with oil to at least 50 % before starting. The drainage pipe should be connected to topmost drainage outlet.

The other end of the pipe should be connected to the oil tank at a point below the oil level.

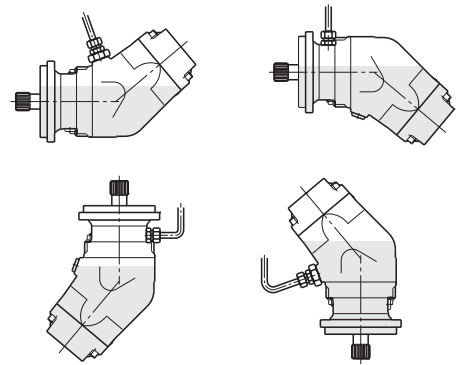

Piping

Recommended oil velocity in pressure line max. 7 m/sec.

Filtering

Cleanliness according to ISO norm 4406, code 16/13.

Temperatures/Housing cooling

Excessive system temperature reduces the life of the shaft seal and can lower the oil viscosity below the recommended level. A system temperature of 60 °C and a drain flow temperature of 90 °C must not be exceeded. Cooling/flushing of the motor housing can be needed to keep the drain flow temperature at an acceptable level.

Suggested flow:

Motor SCM	Flushing l/min	Cont. RPM
012-034	2-8	≥ 2800
047-064	4-10	≥ 2500
084-130	6-12	≥ 2200

Housing flushing can be built up with the help of a flushing valve or taken directly from the return line. When the return pressure is too low this is compensated for by a counter pressure valve. The tank line is connected to the highest point as in the figure.

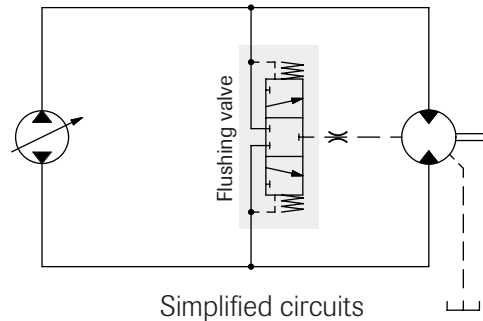
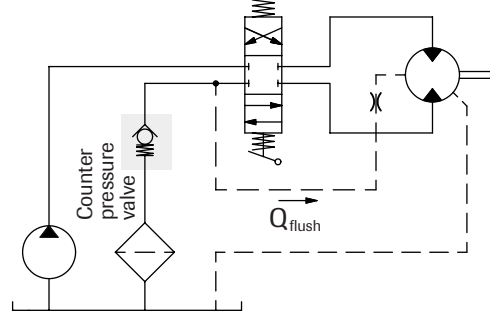
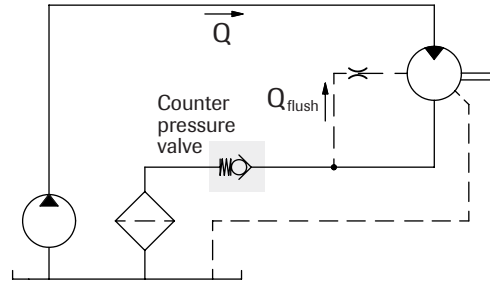
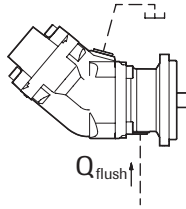

Hydraulic fluids

High performance oils meeting ISO specifications – such as HM, DIN 51524-2HLP, or better – must be used.

A min. viscosity of 10 cSt is required to keep the lubrication at a safe level.

The ideal viscosity is 20 - 40 cSt.

Useful formulaes

Required flow rate $Q = \frac{D \times n}{1000 \times \eta_v}$ litres/min.

Speed $n = \frac{Q \times 1000 \times \eta_v}{D}$ RPM

Torque $M = \frac{D \times \Delta p \times \eta_{hm}}{6.3}$ Nm

Power $P = \frac{Q \times \Delta p \times \eta_t}{60}$ kW

D = displacement, cm³/revolution

n = speed, revolution/min

P = power, kW

Q = flow rate, litres/min

η_v = volumetric efficiency

η_{hm} = hydraulic-mechanical efficiency

η_t = overall efficiency = $\eta_v \times \eta_{hm}$

M = torque, Nm

Δp = pressure difference between the hydraulic motor inlet and outlet, MPa



WARNING

When the motor is in use:

1. Do not touch the pressure pipe
2. Beware of rotating parts
3. The motor and pipes can reach high temperatures