3ME

Aluminium gear motors

Technical Catalogue

E0.130.0417.02.00IM03



GEAR MOTORS

- Displacements from 2.8 cm³/rev to 73.4 cm³/rev (from 0.17 cu.in./rev to 4.48 cu.in./rev).
- Rated pressure up to 250 bar (3625psi).
- Back pressure capability up to 120 bar (1740 psi) only in bi-directional release.
- Speed up to 4500 rpm.
- Flanges, shafts and ports for ISO, DIN and SAE standards.
- Available in uni and bi-directional version for all the sizes, displacements and configurations.
- High volumetric efficiency thanks to an innovative design and an accurate control of machining tolerances.
- Axial compensation achieved by the use of floating bushes that allow high volumetric efficiency throughout the working pressure range.
- DU bearings to ensure high pressure capability.
- 12 teeth integral gear and shaft.
- Aluminium body.
- Cast iron flange and cover.
- Double shaft seals in all motor series. The one which faces the internal side is reinforced.
- Nitrile seals as standard and Viton seals in high temperature applications.
- Available with different valves and circuit configurations built-in rear cover.
- All motors are hydraulically tested after assembly to ensure the highest standard performance.

TECHNICAL DATA

- Minimum operating fluid viscosity	12 mm ² /sec
- Permitted viscosity range	12 - 800 mm ² / sec
- Recommended viscosity range	20 - 80 mm ² / sec
- Permitted viscosity for starting	2000 mm ² / sec
- Fluid operating temperature range	-25 to 85 °C
- Fluid operating temperature range with FPM seals	-20 to 110°C
- Fluid operating temperature range with HNBR seals*	-30 to 110°C
- Hydraulic fluid	mineral oil

*Available on request

DEFINITION OF PRESSURES

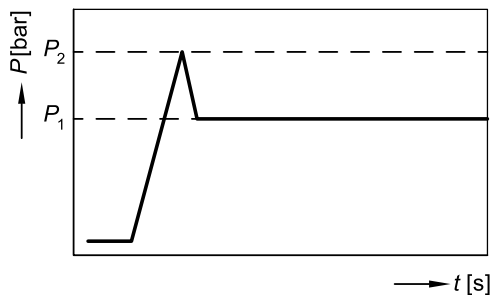

P_1 max. continuous pressure
 P_2 starting pressure (depending on the application, this must be taken into consideration when setting the pressure of the hydraulic system's pressure-relief valve).

EO.100.0417.02.001M01



DRIVE SHAFTS

Radial and axial loads on the shafts must be avoided since they reduce the life of the unit. In order to avoid misalignment during the assembly with the primary engine, a connection with "Oldham" coupling (or coupling having convex toothed hub) is recommended.

ROTATION

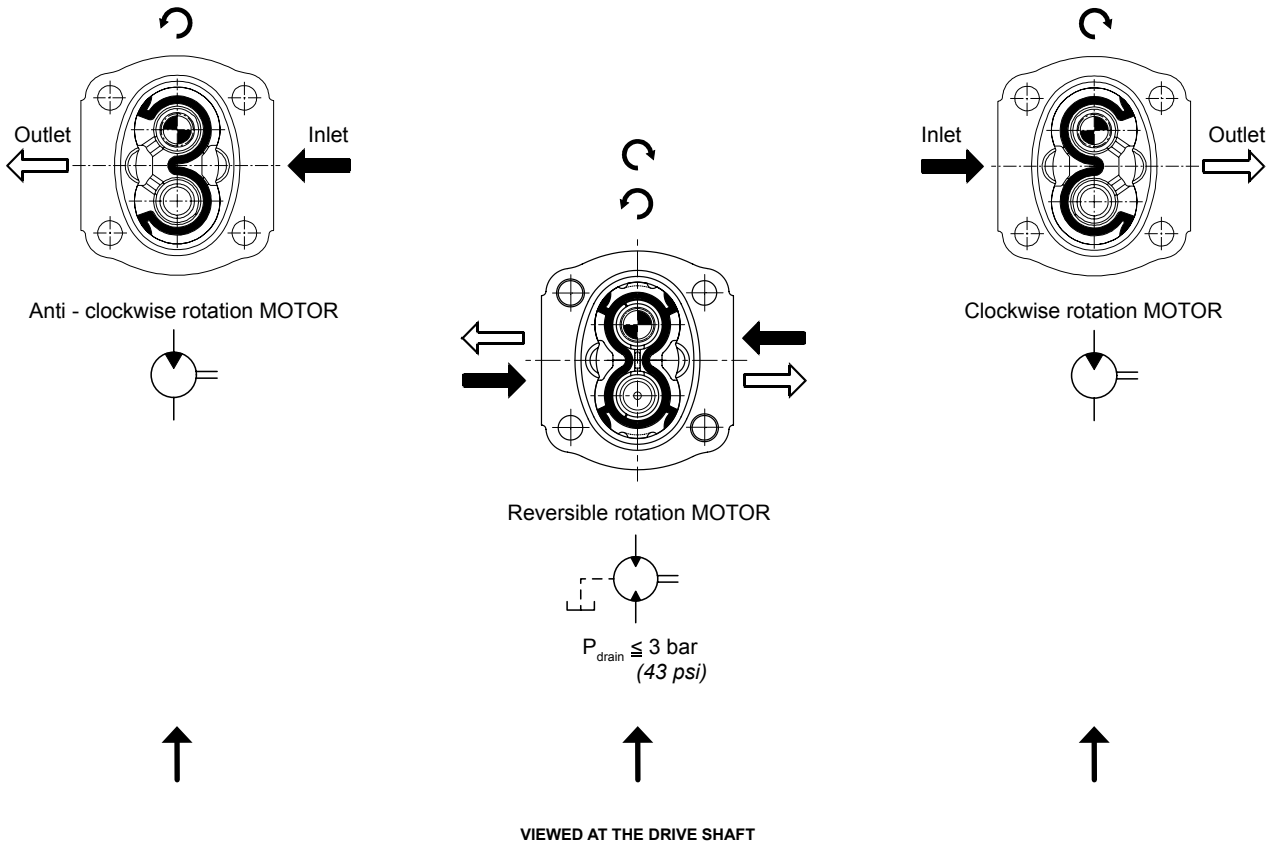

HYDRAULIC PIPE LINE

To calculate hydraulic pipe line size, the designer can use; as an approximate guide, the following fluid speed figures:

From 6 to 10 m/sec on pressure pipe line

From 19.7 to 32.8 ft/sec on pressure pipe line

The lowest fluid speed values in pipe lines is recommended when the operating temperature range is high and/or for continuous duty.

The highest value is recommended when the temperature difference is low and/or for intermittent duty.

In case of reversible motor allowance must be made to ensure the motor is not drained, through the case drain, when stationary.

FILTRATION INDEX RECOMMENDED

Working pressure	>200 bar/2900 psi	<200 bar/2900 psi
Contamination class NAS 1638	9	10
Contamination class ISO 4406	19/18/15	20/19/16
Achieved with filter $\beta_x=75$	15 μm	25 μm

FIRE RESISTENT FLUID

Type	Description	Max pressure	Max speed (rpm)	Temperature
HFB	Oil emulsion with 40% water	130 bar/1880 psi	2500	3°C+65°C
HFC	Water glycol	180 bar/2600 psi	1500	-20°C+65°C
HFD	Phosphate esters		1750	-10°C+80°C

COMMON FORMULAS FOR MOTORS

Based on SI units

Input flow: $Q = \frac{V \cdot n}{1000 \cdot \eta_v}$ l/min

Output torque: $M = \frac{V \cdot \Delta p \cdot \eta_m}{20 \cdot \pi}$ Nm

Output power: $P = \frac{M \cdot n}{9550} = \frac{Q \cdot \Delta p \cdot \eta_t}{600}$ kW

Variables: SI units [US units]

Based on US units

Input flow: $Q = \frac{V \cdot n}{231 \cdot \eta_v}$ [US gal/min]

Output torque: $M = \frac{V \cdot \Delta p \cdot \eta_m}{2 \cdot \pi}$ [lbf·in]

Output power: $P = \frac{M \cdot n}{63\,025} = \frac{Q \cdot \Delta p \cdot \eta_t}{1714}$ [hp]

LEGENDA

- V = Displacement cm³/rev [in³/rev]
- P_{out} = Outlet pressure bar [psi]
- P_{in} = Inlet pressure bar [psi]
- ΔP = $P_{out} - P_{in}$ (system pressure) bar [psi]
- n = Speed min⁻¹ (rpm)
- η_v = Volumetric efficiency
- η_m = Mechanical efficiency
- η_t = Overall efficiency ($\eta_v \cdot \eta_m$)

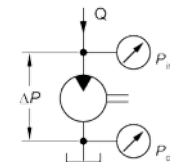

IDENTIFICATION LABEL

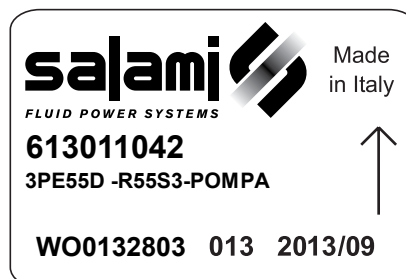

Salami part number _____
Product short description _____

Rotation sense

Product code (for Salami management) _____

Month and year of made _____
Number of assembling _____

EO.100.0417.02.001M01



WORKING CONDITIONS

GROUP 1.5 - E SERIES	Displacement		Max. continuous pressure P ¹		Max. starting pressure P ²		Max. speed	Min. speed
	cm ³ /rev	cu.in/rev	bar	psi	bar	psi		
1.5ME - 2.8	2.8	0.17	250	3625	270	3915	4500	700
1.5ME - 3.5	3.5	0.21	250	3625	270	3915	4500	700
1.5ME - 4.1	4.1	0.25	250	3625	270	3915	4000	700
1.5ME - 5.2	5.2	0.32	230	3335	250	3625	4000	700
1.5ME - 6.2	6.2	0.38	230	3335	250	3625	3600	600
1.5ME - 7.6	7.6	0.46	200	2900	220	3190	3300	600
1.5ME - 9.3	9.3	0.57	180	2610	200	2900	3000	600
1.5ME - 11	11	0.67	170	2465	190	2755	3000	600

GROUP 2 - E SERIES	Displacement		Max. continuous pressure P ¹		Max. starting pressure P ²		Max. speed	Min. speed
	cm ³ /rev	cu.in/rev	bar	psi	bar	psi		
2ME - 4.5	4.6	0.27	250	3625	280	4060	4000	600
2ME - 6.5	6.5	0.4	250	3625	280	4060	4000	600
2ME - 8.3	8.2	0.5	250	3625	280	4060	3600	500
2ME - 10.5*	10.6	0.65	250	3625	280	4060	3500	500
2ME - 11.3	11.5	0.68	250	3625	280	4060	3500	500
2ME - 12.5*	12.7	0.77	250	3625	280	4060	3400	500
2ME - 13.8	13.8	0.84	250	3625	280	4060	3400	500
2ME - 16	16.6	1.01	250	3625	280	4060	3200	450
2ME - 19	19.4	1.15	220	3190	240	3480	3200	450
2ME - 22.5	22.9	1.37	200	2900	220	3190	3000	450
2ME - 26	25.8	1.58	180	2610	200	2900	2850	450

*Available for quantity

GROUP 2.5 - B SERIES	Displacement		Max. continuous pressure P ¹		Max. starting pressure P ²		Max. speed	Min. speed
	cm ³ /rev	cu.in/rev	bar	psi	bar	psi		
2.5MB - 16	16	0.97	250	3625	280	4060	3000	600
2.5MB - 19	19.3	1.17	250	3625	280	4060	3000	600
2.5MB - 22	22.2	1.35	250	3625	280	4060	3000	500
2.5MB - 25	25.2	1.53	250	3625	280	4060	3000	500
2.5MB - 28	27.6	1.68	250	3625	280	4060	3000	500
2.5MB - 32	32.4	1.97	230	3330	250	3625	3000	500
2.5MB - 38	38.1	2.32	200	2900	220	3190	2750	400
2.5MB - 44	44.2	2.69	170	2465	190	2755	2500	400

GROUP 3 - E SERIES	Displacement		Max. continuous pressure P ¹		Max. starting pressure P ²		Max. speed	Min. speed
	cm ³ /rev	cu.in/rev	bar	psi	bar	psi		
3ME - 27	27	1.65	250	3625	280	4060	3000	600
3ME - 33	33.5	2.04	250	3625	280	4060	3000	600
3ME - 38	38.7	2.36	250	3625	280	4060	2750	500
3ME - 46	46.9	2.86	250	3625	270	3915	2750	500
3ME - 55	54.1	3.3	220	3190	240	3480	2500	400
3ME - 65	63.1	3.85	200	2900	220	3190	2500	400
3ME - 75*	73.4	4.48	180	2610	200	2900	2500	400

*Available for quantity

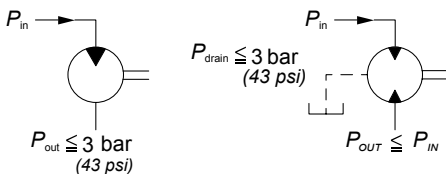

The values shown in the picture represents the standard working situation.
 Max drain pressure is influenced by rotational speed of the unit.
 For pressure higher than 3 bar please contact sales department.
On request available shaft seal for high P drain (20 bar).

E0.100.0417.02.00IM01



INDEX

Shafts And Flanges Combinations	195
Assembling Dimensions And Working Conditions.....	196
Flanged And Threaded Ports.....	198
Drive Shafts	200
Mounting Flanges	201
Outrigger Bearing	202
Rear Covers	204
Performance Curves.....	205
How To Order Single Motors	208

Final revised edition-April 2017





The data in this catalogue refers to the standard product.

The policy of Salami S.p.A. consists of a continuous improvement of its products. It reserves the right to change the specifications of the different products whenever necessary and without giving prior information.

If any doubts, please get in touch with our sales department.

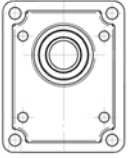
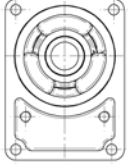
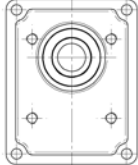
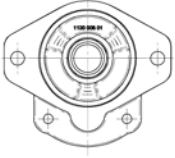

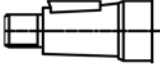
SHAFTS AND FLANGES COMBINATIONS

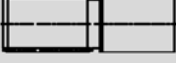
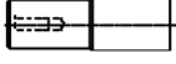
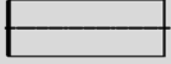
<p>3ME</p>	 CODE P2 - European stand.	 CODE B6 - German stand.	 CODE P3 - European stand. for 3,5PC	 CODE S3 - SAE B
 CODE 35 - Tapered 1:5		<p>35B6</p>		
 CODE 38 - Tapered 1:8	<p>38P2</p>			
 CODE 48 - Tapered 1:8 for 3,5PC			<p>48P3</p>	
 CODE 55 - SAE B 13T				<p>55S3</p>
 CODE 56 - SAE BB 15T				<p>56S3</p>
 CODE 87 - SAE B parallel				<p>87S3</p>
 CODE 88 - SAE BB parallel				<p>88S3</p>

Note: other versions available, see shafts and flanges information.

EO.130.0417.02.001M04



Displacements up to 4.48 cu.in./rev
Pressure up to 4350 psi

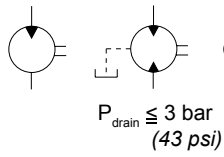

GEAR MOTORS

Displacements up to 73.4 cm³/rev
Pressure up to 300 bar

ASSEMBLING DIMENSIONS AND WORKING CONDITIONS

Type		27	33	38	46	55	65	75*
Displacement	cm³/rev	27	33.5	38.7	46.9	54.1	63.1	73.4
	cu.in./rev	1.65	2.04	2.36	2.86	3.3	3.85	4.48
Dimension A	mm	79	84	88	104	110	117	124
	in	3.11	3.31	3.46	4.09	4.33	4.61	4.88
Dimension C	mm	39.5	42	44	52	55	58.5	62
	in	1.56	1.65	1.73	2.05	2.17	2.30	2.44
Max continuous pressure	P ¹ bar	250	250	250	250	220	200	180
	psi	3625	3625	3625	3625	3190	2900	2610
Max starting pressure	P ² bar	280	280	280	270	240	220	200
	psi	4060	4060	4060	3915	3480	3190	2900
Max speed at	P ² rpm	3000	3000	2750	2750	2500	2500	2500
	P ¹ rpm	600	600	500	500	400	400	400
Weight	kg	9.10	9.46	9.60	10.40	10.80	11.00	11.50
	lbs	20.06	20.86	21.16	22.93	23.81	24.25	25.35

*Displacement 75 is special release, please contact sales department.

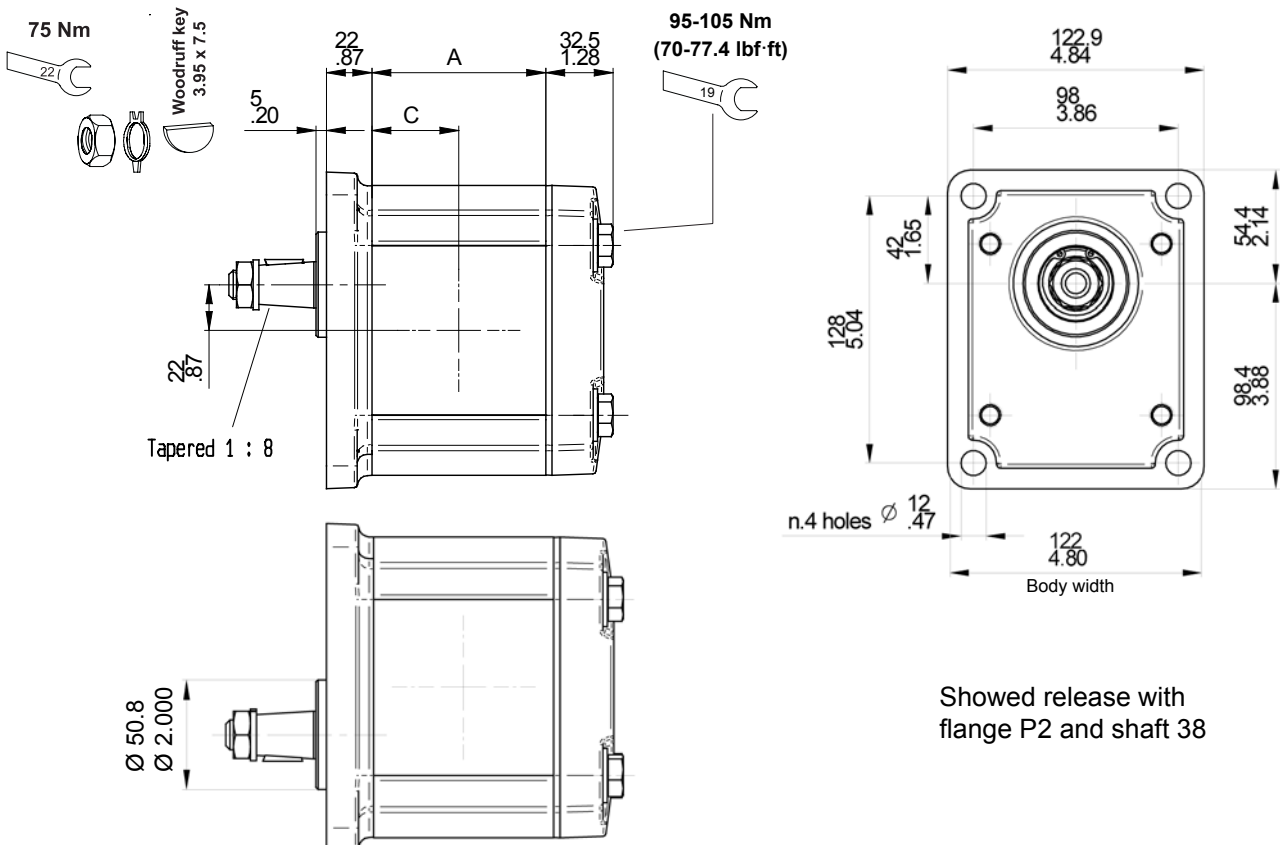

E0.130.0417.02.00IM04



Displacements up to 4.48 cu.in./rev
Pressure up to 4350 psi

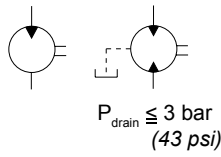

GEAR MOTORS

Displacements up to 73.4 cm³/rev
Pressure up to 300 bar

ASSEMBLING DIMENSIONS

Type		46	55	65	75*
Displacement	cm ³ /rev	46.9	54.1	63.1	73.4
	cu.in./rev	2.86	3.3	3.85	4.48
Dimension A	mm	104	110	117	124
	in	4.09	4.33	4.61	4.88
Dimension C	mm	52	55	58.5	62
	in	2.05	2.17	2.30	2.44
Weight	kg	10.1	10.5	10.8	11.2
	lbs	22.3	23	23.8	24.6

*Displacements 75 are special release, please contact sales department.

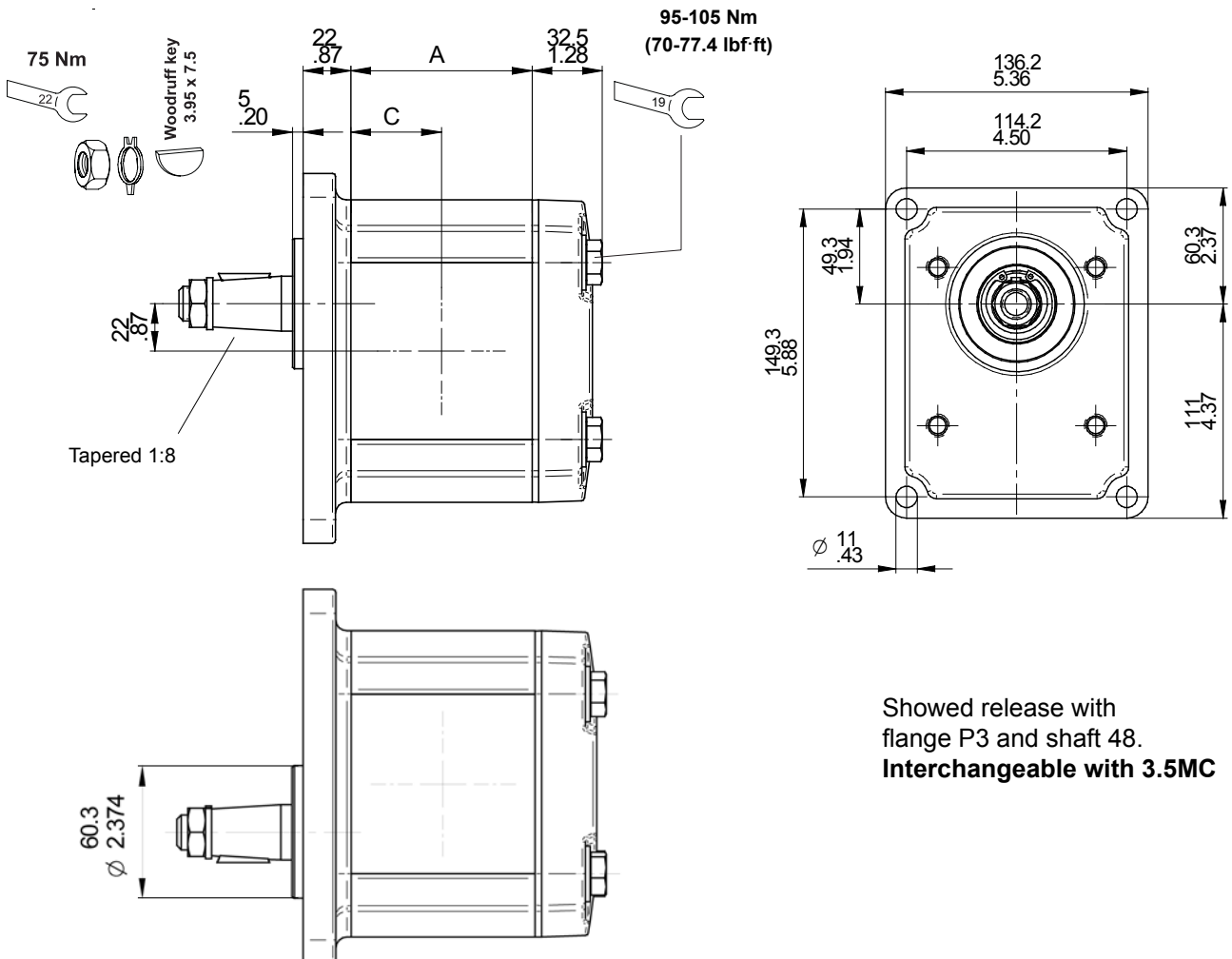

Showed release with flange P3 and shaft 48.
Interchangeable with 3.5MC

EO.130.0417.02.001M04



FLANGED AND THREADED PORTS

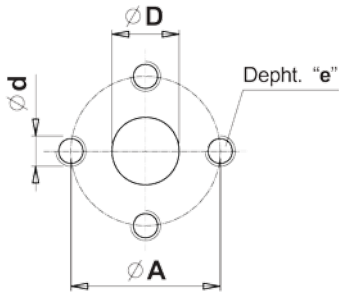

code P

Flanged ports
European standard

UNI-DIRECTIONAL MOTORS	TYPE	OUTLET				INLET			
		Ø D	Ø A	d	e	Ø D	Ø A	d	e
From 27 to 55	27 (1.06")	51 (2.01")	M10	16 (0.63")	16 (0.63")	40 (1.57")	M8	16 (0.63")	
	From 65 to 75	33 (1.3")	62 (2.44")		M12	21 (0.83")	51 (2.01")		M10



BI-DIRECTIONAL MOTORS	TYPE	OUTLET				INLET			
		Ø D	Ø A	d	e	Ø D	Ø A	d	e
27	19 (0.75")	40 (1.57")	M8	16 (0.63")	19 (0.75")	40 (1.57")	M8	16 (0.63")	
From 33 to 75	27 (1.06")	51 (2.01")	M10		27 (1.06")	51 (2.01")	M10		

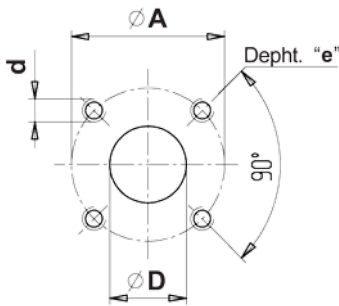

code B

Flanged ports
German standard

UNI-DIRECTIONAL MOTORS	TYPE	OUTLET				INLET			
		Ø D	Ø A	d	e	Ø D	Ø A	d	e
From 27 to 75	27 (1.06")	55 (2.17")	M8	13 (0.51")	19 (0.75")	55 (2.17")	M8	13 (0.51")	

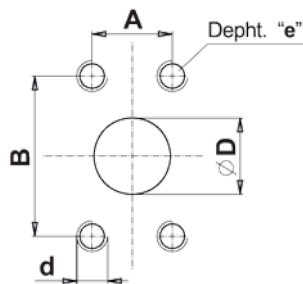

code W

Flanged ports
SAE J518
METRIC THREAD

UNI-DIRECTIONAL MOTORS	TYPE	OUTLET					INLET				
		ØD	B	A	d	e	ØD	B	A	d	e
From 27 to 38	26 (1.02")	52.4 (2.06")	26.2 (1.03")	M10	18 (0.71")	19 (0.75")	47.6 (1.87")	22.2 (0.87")	M10	18 (0.71")	
	From 46 to 75	32 (1.26")	58.7 (2.31")			30.2 (1.19")	26 (1.02")	52.4 (2.06")			26.2 (1.03")

E0.130.0417.02.00IM04



FLANGED AND THREADED PORTS

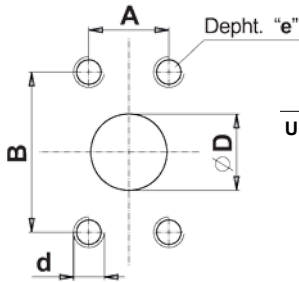

UNI-DIRECTIONAL MOTORS	TYPE	OUTLET					INLET				
		ØD	B	A	d	e	ØD	B	A	d	e
	From 27 to 38	26 (1.02")	52.4 (2.06")	26.2 (1.03")	3/8 16 UNC	18 (0.71")	19 (0.75")	47.6 (1.87")	22.2 (0.87")	3/8 16 UNC	18 (0.71")
	From 46 to 75	32 (1.26")	58.7 (2.31")	30.2 (1.19")	7/16 14 UNC		26 (1.02")	52.4 (2.06")	26.2 (1.03")		

code S

Flanged ports
SAE J518
AMERICAN STANDARD
THREAD

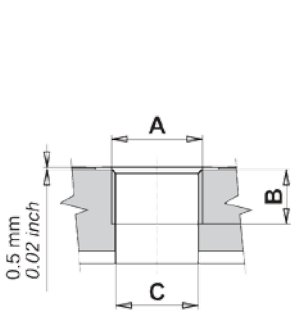

code G

Threaded ports
GAS (BSPP)

UNI-DIRECTIONAL MOTORS	TYPE	OUTLET			INLET		
		A	B	C	A	B	C
	From 27 to 38	G1	22 (0.86")	27 (1.06")	G1	22 (0.86")	27 (1.06")
	From 46 to 75	G1 1/4	24 (0.94")	32.5 (1.28")			

BI-DIRECTIONAL MOTORS	TYPE	OUTLET			INLET		
		A	B	C	A	B	C
	From 27 to 75	G1	22 (0.86")	30.5 (1.20")	G1	22 (0.87")	30.5 (1.20")

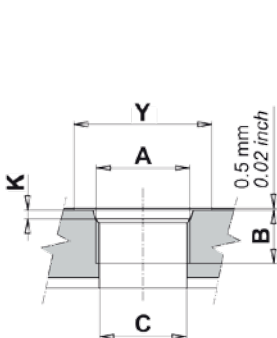

code R

Threaded ports
SAE (ODT)

UNI-DIRECTIONAL MOTORS	TYPE	OUTLET					INLET				
		A	B	C	Y	K	A	B	C	Y	K
	From 27 to 38	1-5/16-12 UN (SAE 16)	19 (0.75")	25 (0.98")	49 (1.93")	3.3 (0.12")	1-1/16-12 UN (SAE 12)	19 (0.75")	21 (0.83")	41 (1.61")	3.3 (0.13")
	From 46 to 75	1-5/8-12 UN (SAE 20)		27 (1.06")	58 (2.28")		1-5/16-12 UN (SAE 16)		25 (0.98")	49 (1.93")	

BI-DIRECTIONAL MOTORS	TYPE	OUTLET					INLET				
		A	B	C	Y	K	A	B	C	Y	K
	From 27 to 38	1-1/16-12 UN (SAE 12)	19 (0.75")	21 (0.83")	41 (1.61")	3.3 (0.12")	1-1/16-12 UN (SAE 12)	19 (0.75")	21 (0.83")	41 (1.61")	3.3 (0.13")
	From 46 to 75	1-5/16-12 UN (SAE 16)		25 (0.98")	49 (1.93")		1-5/16-12 UN (SAE 16)		25 (0.98")	49 (1.93")	

EO.130.0417.02.001M04



DRIVE SHAFTS

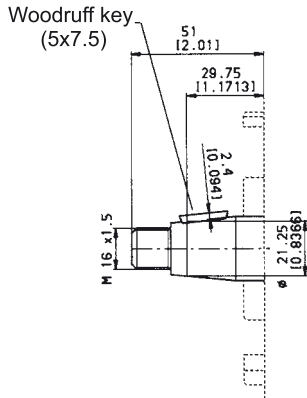

code 35 Max torque 260 Nm (2300 lbf in)
European tapered 1:5

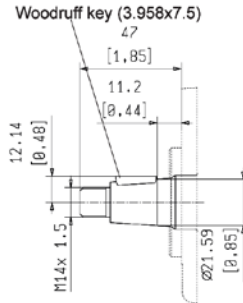

code 38 Max torque 250 Nm (2213 lbf in)
European tapered 1:8

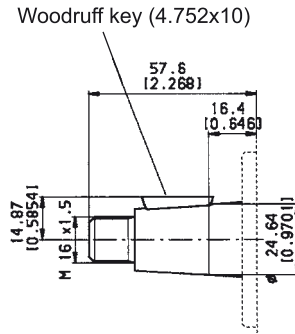

code 48 Max torque 350 Nm (3100 lbf in)
European tapered 1:8 for 3.5PC

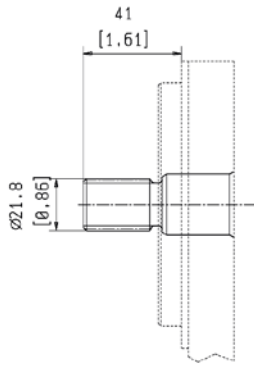

code 55 Max torque 330 Nm (2921 lbf in)
SAE B 13T-16/32DP Ansi B92 1a 1976

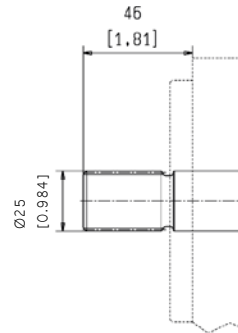

code 56 Max torque 480 Nm (4250 lbf in)
SAE BB 15T-16/32DP Ansi B92 1a 1976

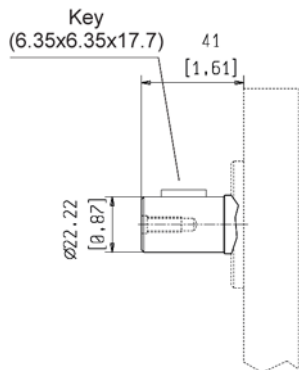

code 87 Max torque 220 Nm (1950 lbf in)
SAE B Parallel

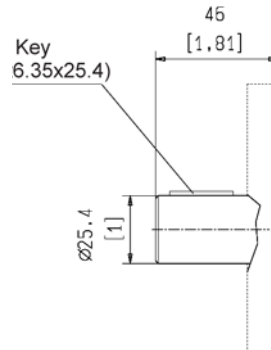

code 88 Max torque 320 Nm (2830 lbf in)
SAE BB Parallel

E0.130.0417.02.00IM04



MOUNTING FLANGES

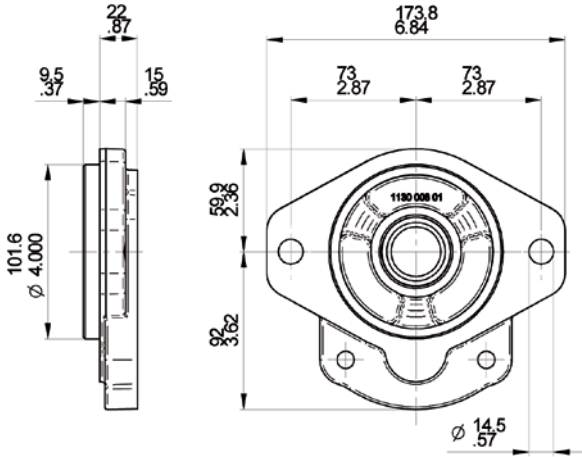

S3	SAE B
With shaft code 55-56-87-88	

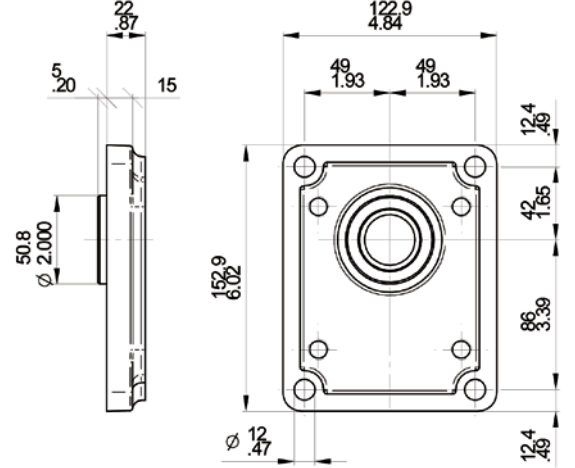

P2	European standard
With shaft code 38	

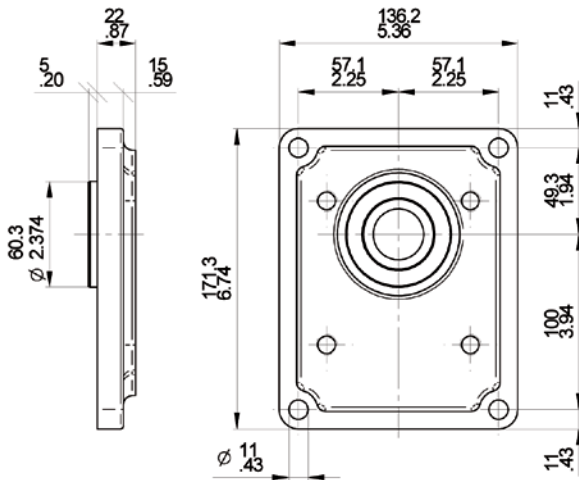

P3	European standard
With shaft code 48	

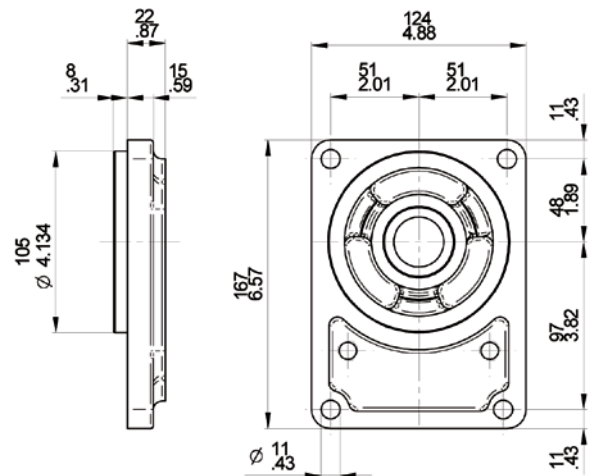

B6	German standard
With shaft code 05-35	

EO.130.0417.02.001M04



OUTRIGGER BEARING

The following diagrams show radial load capability of the bearing.

Calculation according to ISO 281 at 10 cSt.

TYPE	H
27	79 (3.11")
33	84 (3.31")
38	88 (3.46")
46	104 (4.09")
55	110 (4.33")
65	117 (4.61")

L=Distance between mounting flange and radial force point of application.

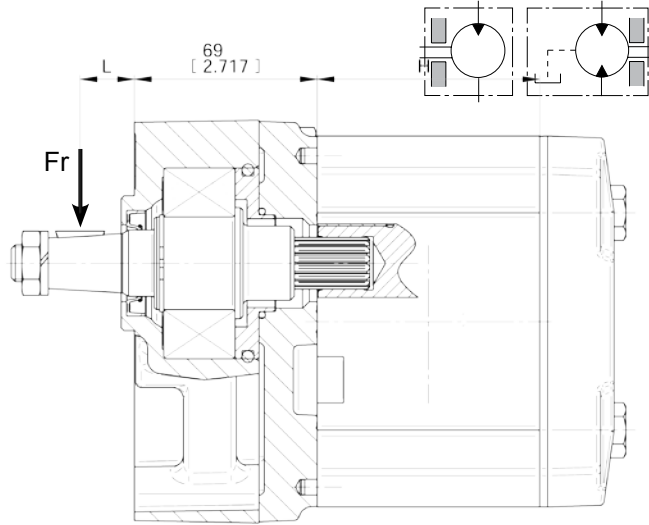

Example:

Fr = 3000 N

L = 35

Speed = 2500 rpm

Expected life: 1000 hrs

For Code CP

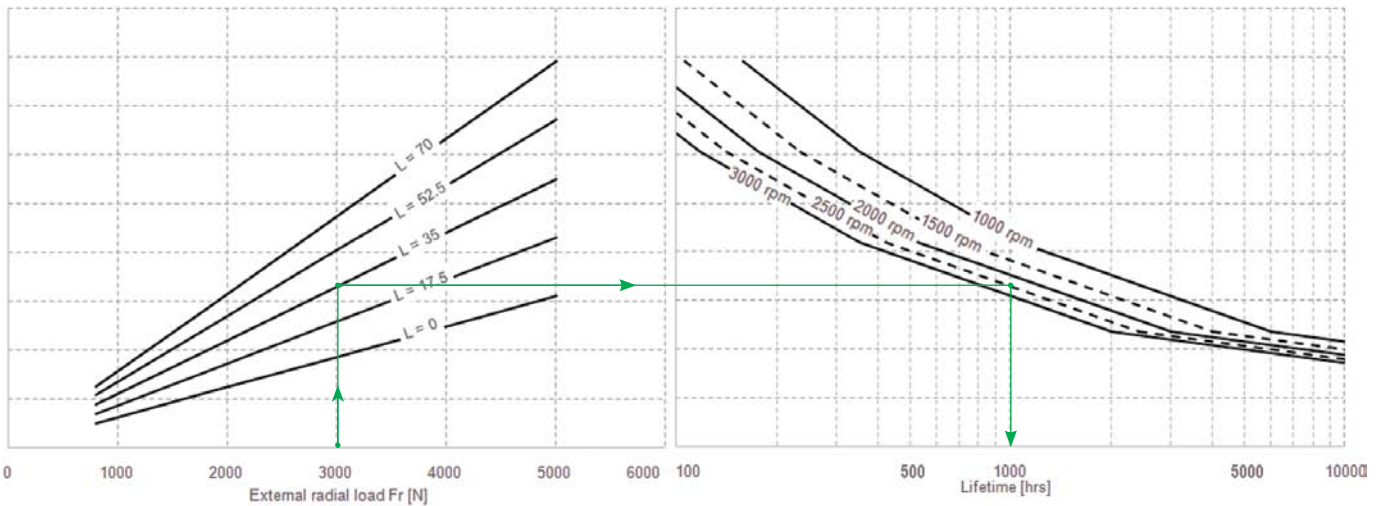

For Code CSB

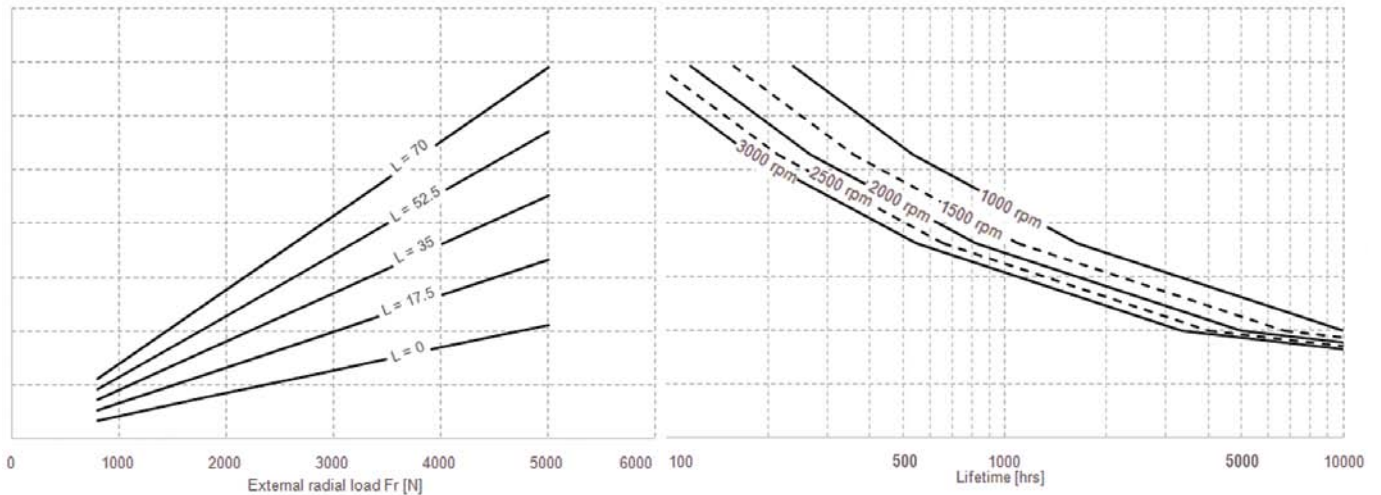

E0.130.0417.02.00IM04



MOUNTING FLANGES WITH BEARING

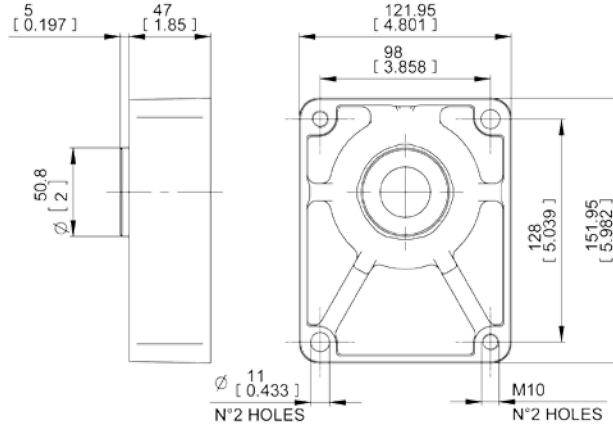

CP	European standard Ø50.8 mm
With shaft code 38	

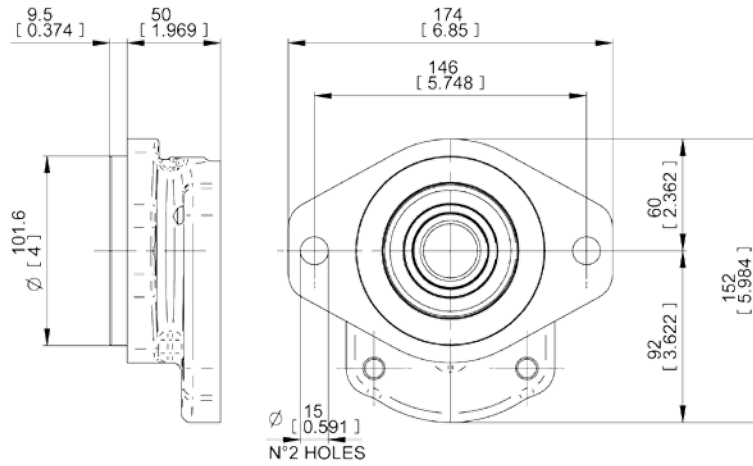

CSB	SAE B
With shaft code 55-56-87-88	

EO.130.0417.02.001M04



REAR COVERS

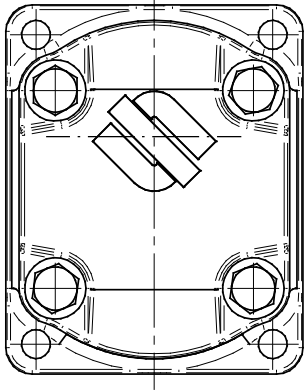

Standard rear cover for unidirectional motors

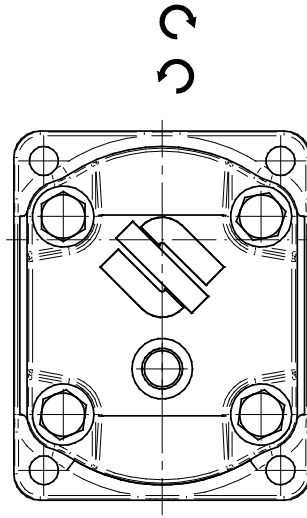

Standard rear cover for reversible motors, with external drain C.
For the dimension C please see the table here below

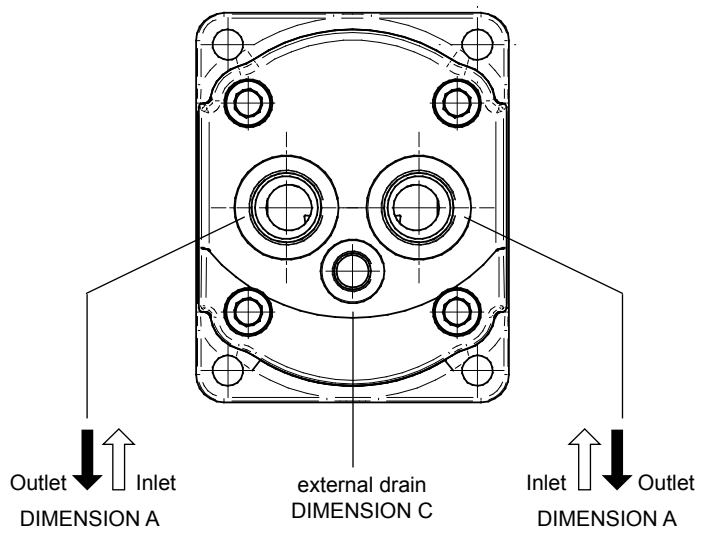
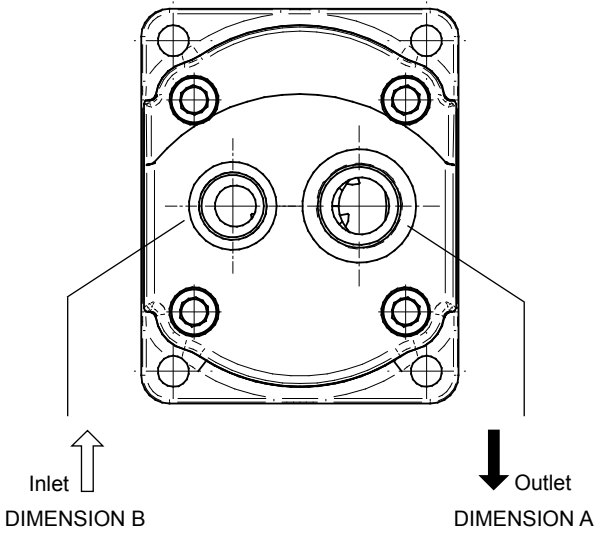

UNIDIRECTIONAL MOTORS

A	B
G1	G3/4
1-5/16-12 UN-2B (SAE16)	1-1/16-12 UN-2B (SAE12)

code 1

BIDIRECTIONAL MOTORS

A	C
G3/4	G3/8
1-1/16-12 UN-2B (SAE12)	9/16-18 UN-2B (SAE6)

E0.130.0417.02.00IM04



PERFORMANCE CURVES

Performance curves carried out with oil viscosity at 21 cSt and oil temperature at 50°C

INPUT FLOW

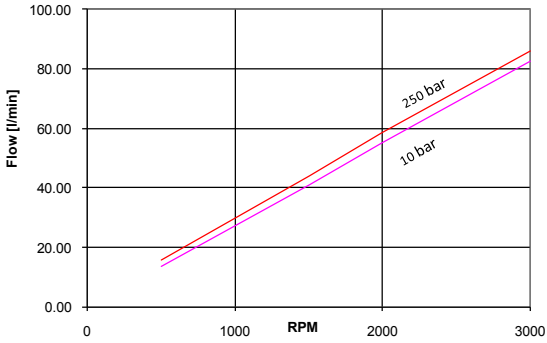

3ME - 27

Output torque/power

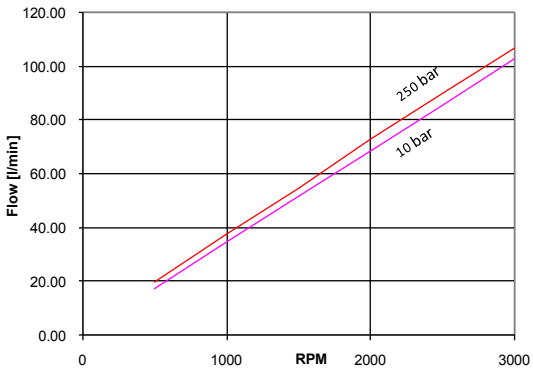
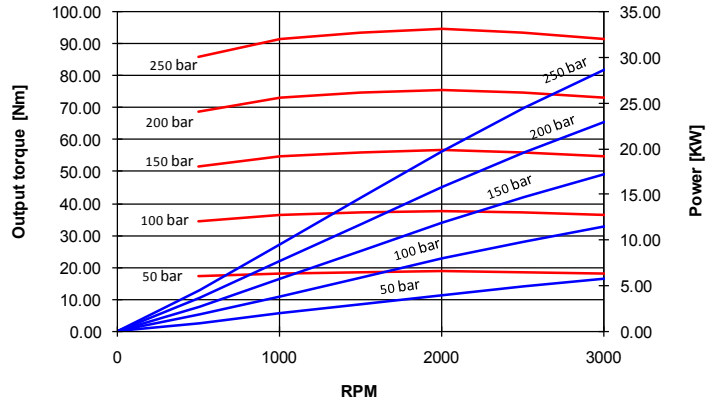

3ME - 33

Output torque/power

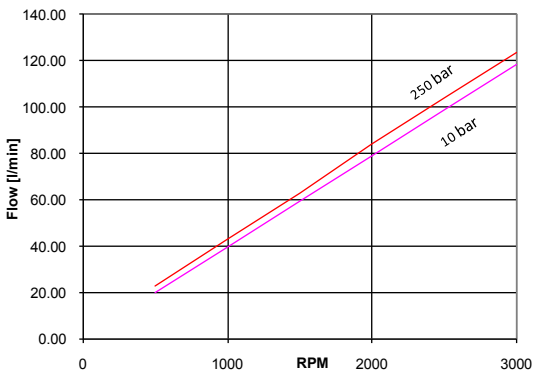
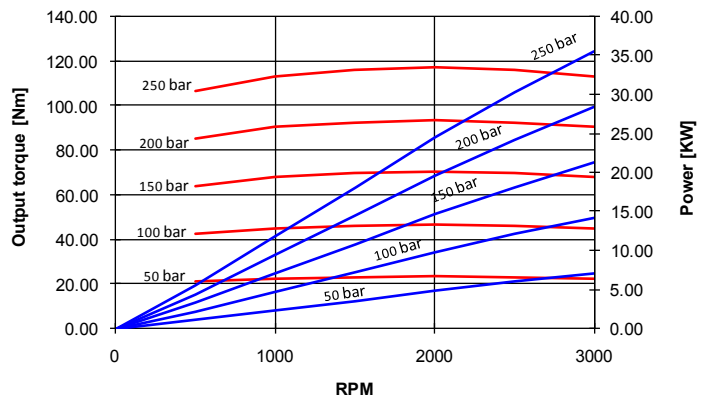

3ME - 38

Output torque/power

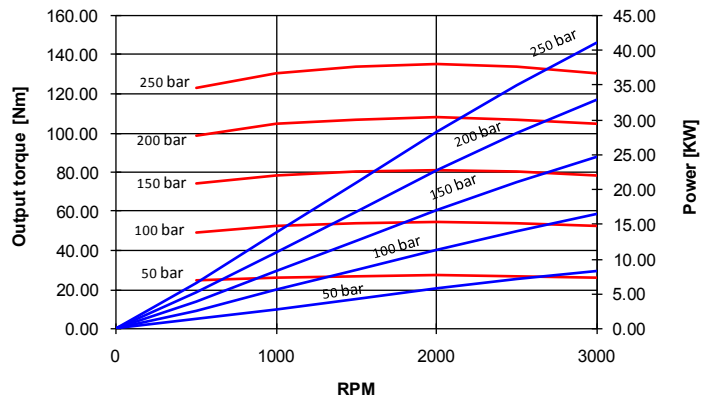

EO.130.0417.02.001M04



PERFORMANCE CURVES

Performance curves carried out with oil viscosity at 21 cSt and oil temperature at 50°C

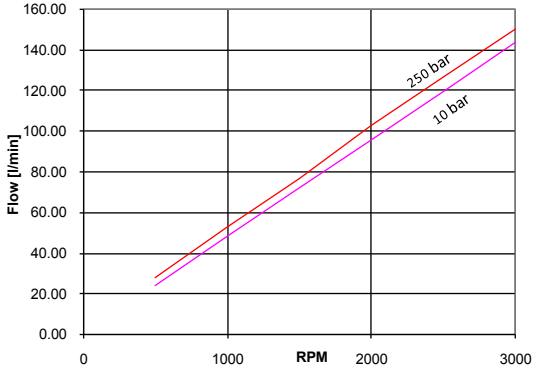

3ME - 46

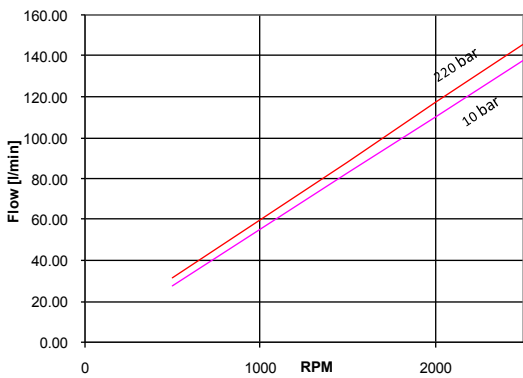
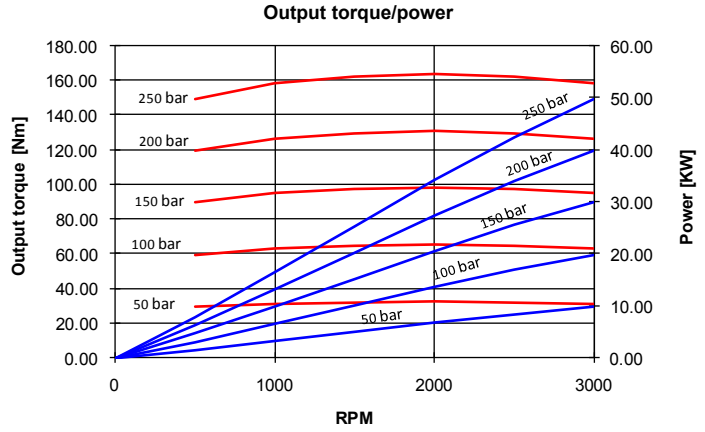

3ME - 55

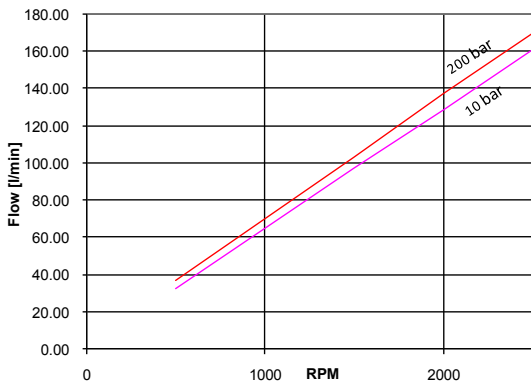
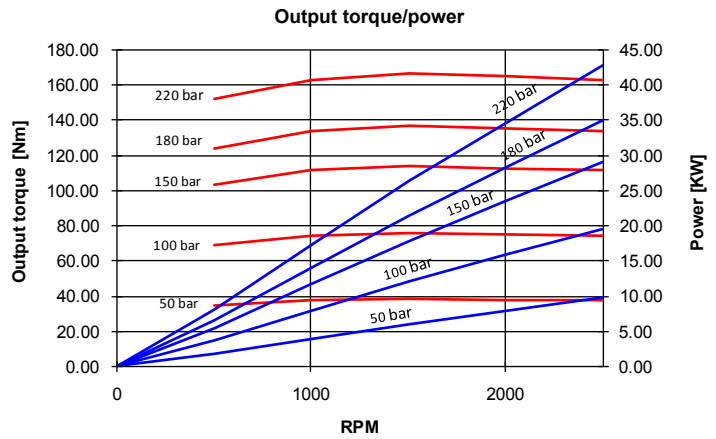

3ME - 65

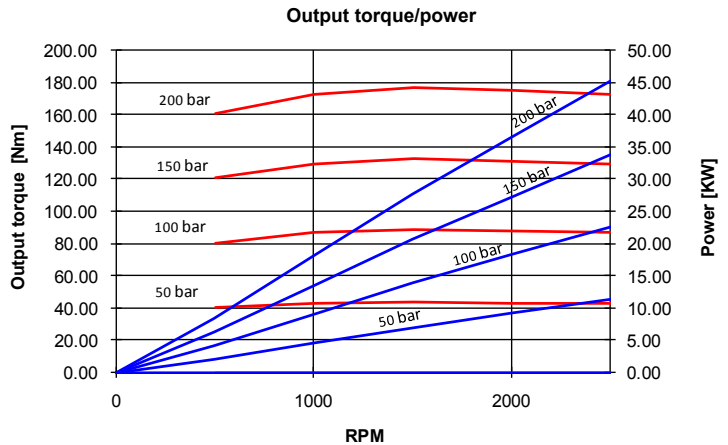

E0.130.0417.02.00IM04



PERFORMANCE CURVES

Performance curves carried out with oil viscosity at 21 cSt and oil temperature at 50°C

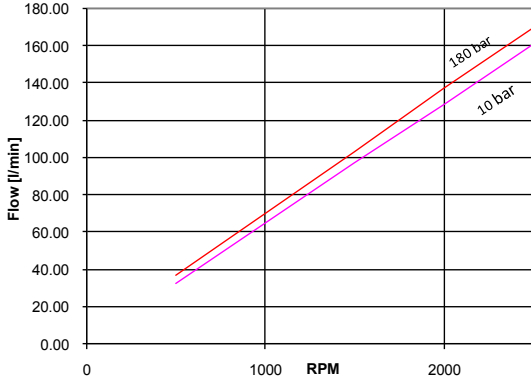

3ME - 75

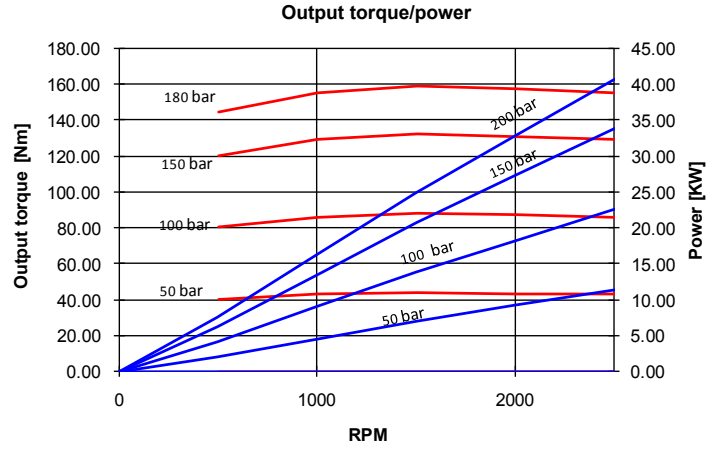

SINGLE MOTORS

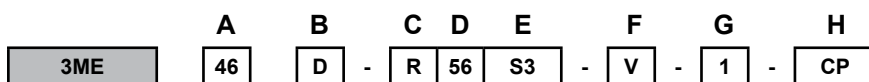

TYPE	A	DISPLACEMENTS
21	20.6 cm ³ /rev.	1.26 cu.in/rev.
27	27 cm ³ /rev.	1.65 cu.in/rev.
33	33.5 cm ³ /rev.	2.04 cu.in/rev.
38	38.7 cm ³ /rev.	2.36 cu.in/rev.
46	46.9 cm ³ /rev.	2.86 cu.in/rev.
55	54.1 cm ³ /rev.	3.3 cu.in/rev.
65	63.1 cm ³ /rev.	3.85 cu.in/rev.
75	73.4 cm ³ /rev.	4.48 cu.in/rev.

ROTATION (page 132)	CODES	B
Clockwise	D	
Anti-clockwise	S	
Reversible	R	

PORTS (page 198)	CODES	C
Flanged ports european standard	P	
Flanged ports german standard	B	
Threaded ports GAS (BSPP)	G	
Threaded ports SAE (ODT)	R	
Flanged ports SAE J518 AMERICAN STANDARD THREAD	S	
Flanged ports SAE J518 METRIC THREAD	W	

DRIVE SHAFT (page 200)	CODES	D
European Tapered 1:5	35	
European Tapered 1:8	38	
European Tapered 1:8	48	
SAE B splined 13T	55	
SAE BB splined 15T	56	
SAE B parallel	87	
SAE BB parallel	88	

H	OUTRIGGER BEARING (page 202)	CODES
	European standard	CP
	German standard	CSB

G	PORTS POSITION	CODE
	Lateral ports standard	
	Rear ports (page)	1

F	SEAL	CODE
	Buna standard	
	Viton	V

E	MOUNTING FLANGES (page 201)	CODES
	SAE B 2 Bolts	S3
	European standard Ø50.8	P2
	European standard Ø60.3	P3
	German standard Ø105	B6

Order example 3ME 46D, ports SAE (R), drive shaft (56), mounting flange (S3)
3ME46D-R56S3

E0.130.0417.02.00IM04



You can find our most up to date “STANDARD SALES CONDITIONS” on our website.

Potete trovare le nostre più aggiornate “CONDIZIONI DI VENDITA STANDARD”
sul nostro sito.

www.salami.it

T. +39 059 387 411

sales@salami.it

Watch our tutorials on youtube channel



Salami Fluid Power
Salami Fluid Power World
Salami Fluid Power France
Salami Fluid Power España
Salami Fluid Power Deutsch

SALAMI S.P.A.

Via Emilia Ovest 1006
41121 Modena (Italy)
T. +39 059 387 411
F. +39 059 387 639
sales@salami.it

SALAMI ESPAÑA

Poligono Industrial Armenteres
C/Primer de Maig, 18, Nave 4
08980 San Feliu de Llobregat
Barcelona
T. +34-93-6665451
F. +34-93-6667826
info@salamispain.com

SALAMI FRANCE

22, rue Louis Saillant
69120 Valux en Velin
Lyon
T. +33-04-78809941
F. +33-04-78803669
e.pasian@salami.fr

SALAMI HYDRAULICS N.A INC

4630 Crossroads Park Drive
Liverpool
NY 13088 - USA
T. +1-315-295-2363
F. +1-315-295-2364
info@salamihydraulics.com