2PE

Aluminium gear pumps

Technical Catalogue

E0.120.0417.02.00IM03



GEAR PUMPS

SALAMI gear pumps are available with displacements from 1.4 cm³/rev to 99 cm³/rev (*from 0.09 cu.in/rev to 6.03 cu.in/rev*).

Multiple pumps can always be relized combining stages taken from different or same series.

Several options of shafts, flanges and ports as for European, German and American standards are available for all the pumps.

SALAMI gear pumps offer:

- High volumetric efficiency thanks to an innovative design and an accurate control of machining tolerances.
- Axial compensation achieved by the use of floating bushes that allow high volumetric efficiency throughout the working pressure range.
- DU bearings to ensure high pressure capability.
- 12 teeth integral gear and shaft.
- Aluminium body.
- Cast iron flange and cover.
- Double shaft seals.
- Nitrile seals as standard and Viton seals in high temperature applications.
- All pumps are hydraulically tested after assembly to ensure the highest standard performance.
- Gear pumps are ideal for mobile equipment including: snow plows, light duty equipment, farm vehicles, town trucks, cherry pickers, lift gates, utility vehicles, aerial devices, hoists, spreaders, fan drive.
- Also available Bidirectional rotation.

TECHNICAL DATA

- Pump inlet pressure (absolute pressure)	0.8 to 1.5 bar (11.6 to 21.7 psi)
- Minimum operating fluid viscosity	12 mm ² / sec
- Max starting viscosity	800 mm ² / sec
- Suggested fluid viscosity range	17 - 65 mm ² / sec
- Fluid operating temperature range	-20 to 80 °C
- Fluid operating temperature range with FPM seals (Viton)	-15 to 110°C
- Fluid operating temperature range with HNBR seals*	-30 to 110°C
- Hydraulic fluid	mineral oil

*Available on request.

DEFINITION OF PRESSURES

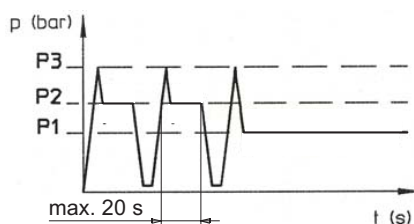

P3 = Peak pressure

P2 = Intermittent operating pressure (1/3 of working time)

P1 = Continuous operating pressure



DRIVE SHAFTS

Radial and axial loads on the shafts must be avoided since they reduce the life of the unit. In order to avoid misalignment during the assembly with the primary engine, a connection with “Oldham” coupling (or coupling having convex toothed hub) is recommended.

ROTATION

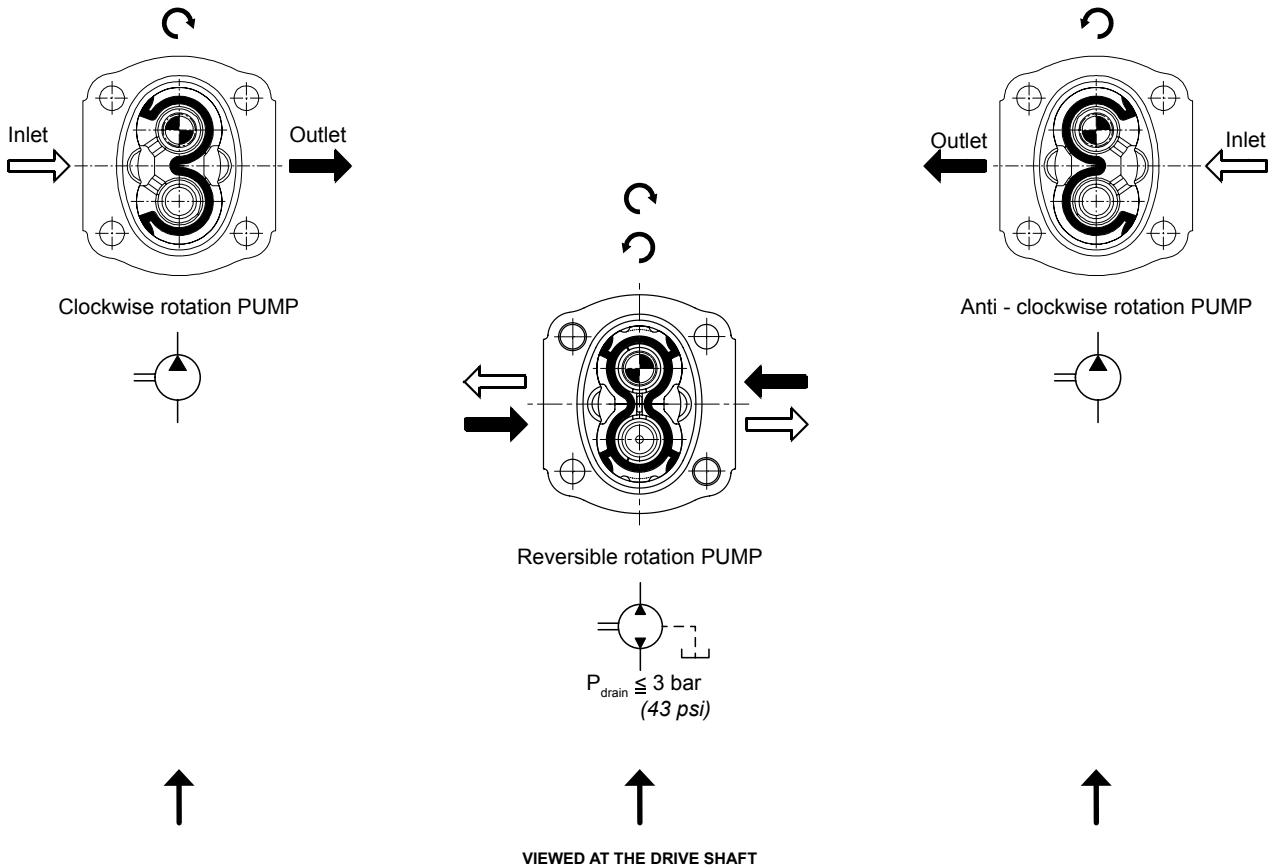

HYDRAULIC PIPE LINE

To ensure favorable suction conditions it is important to keep pressure drop in suction pipe line to a minimum value (see TECHNICAL DATA). To calculate hydraulic pipe line size, the designer can use; as an approximate guide, the following fluid speed figures:

From 1 to 2 m/sec on suction pipe line
From 6 to 10 m/sec on pressure pipe line

From 3.28 to 6.36 ft/sec on suction pipe line
From 19.7 to 32.8 ft/sec on pressure pipe line

The lowest fluid speed values in pipe lines is recommended when the operating temperature range is high and/or for continuous duty.

The highest value is recommended when the temperature difference is low and/or for intermittent duty.

When tandem pumps are supplied by 2 different reservoirs with 2 different fluids it is necessary to specify “AS” version.

FILTRATION INDEX RECOMMENDED

Working pressure	>200 bar/2900 psi	<200 bar/2900 psi
Contamination class NAS 1638	9	10
Contamination class ISO 4406	19/18/15	20/19/16
Achieved with filter $\beta_x=75$	15 μm	25 μm

FIRE RESISTENT FLUID

Type	Description	Max pressure	Max speed (rpm)	Temperature
HFB	Oil emulsion with 40% water	130 bar/1880 psi	2500	3°C+65°C
HFC	Water glycol	180 bar/2600 psi	1500	-20°C+65°C
HFD	Phosphate esters		1750	-10°C+80°C

COMMON FORMULAS FOR PUMPS

$$C = \text{Input torque} = \frac{q \cdot \Delta p}{62.8 \cdot \eta_m} \text{ (Nm)}$$

$$P = \text{Input power} = \frac{q \cdot n \cdot \Delta p \cdot 10^{-3}}{600 \eta_m} \text{ (kW)}$$

$$Q = \text{Outlet flow} = \frac{q \cdot n \cdot \eta_v}{1000} \text{ (l/min)}$$

LEGENDA

Δp = Working pressure (bar)

q = Displacement (cm^3/rev)

n = Speed (min^{-1})

η_m = Mechanical eff. (0.92)

η_v = Volumetric eff. (0.95)

IDENTIFICATION LABEL

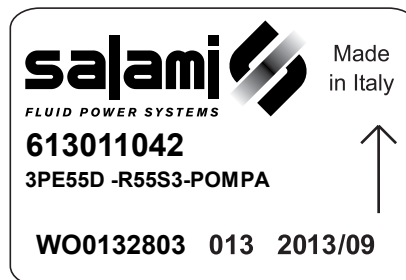

Salami part number
Product short description

Rotation sense

Product code (for Salami management)

Month and year of made
Number of assembling

EO.100.0417.02.001M01

WORKING CONDITIONS

	Displacement		Continuous pressure P ^{1**}		Intermittent pressure P ²		Peak pressure P ³		Max. speed	Min. speed
	cm ³ /rev	cu.in/rev	bar	psi	bar	psi	bar	psi		
GROUP 1.5 - E SERIES										
1.5PE - 1.4	1.4	0.09	250	3625	270	3915	290	4205	5000	700
1.5PE - 2.1	2.1	0.13	250	3625	270	3915	290	4205	5000	700
1.5PE - 2.8	2.8	0.17	250	3625	270	3915	290	4205	4500	700
1.5PE - 3.5	3.5	0.21	250	3625	270	3915	290	4205	4500	700
1.5PE - 4.1	4.1	0.25	250	3625	270	3915	290	4205	4000	700
1.5PE - 5.2	5.2	0.32	230	3335	250	3625	270	3915	4000	700
1.5PE - 6.2	6.2	0.38	230	3335	250	3625	270	3915	3600	600
1.5PE - 7.6	7.6	0.46	200	2900	220	3190	250	3625	3300	600
1.5PE - 9.3	9.3	0.57	180	2610	200	2900	240	3480	3000	600
1.5PE - 11	11	0.67	170	2465	190	2755	220	3190	3000	600

	Displacement		Continuous pressure P ^{1**}		Intermittent pressure P ²		Peak pressure P ³		Max. speed	Min. speed
	cm ³ /rev	cu.in/rev	bar	psi	bar	psi	bar	psi		
GROUP 2 - E SERIES										
2PE - 3.2*	3.2	0.19	250	3625	280	4060	300	4350	4000	600
2PE - 3.9*	3.9	0.24	250	3625	280	4060	300	4350	4000	600
2PE - 4.5	4.6	0.27	250	3625	280	4060	300	4350	4000	600
2PE - 6.5	6.5	0.4	250	3625	280	4060	300	4350	4000	600
2PE - 8.3	8.2	0.5	250	3625	280	4060	300	4350	3500	500
2PE - 10.5	10.6	0.65	250	3625	280	4060	300	4350	3500	500
2PE - 11.3	11.5	0.68	250	3625	280	4060	300	4350	3500	500
2PE - 12.5	12.7	0.77	250	3625	280	4060	300	4350	3500	500
2PE - 13.8	13.8	0.84	250	3625	280	4060	300	4350	3500	500
2PE - 16	16.6	1.01	250	3625	280	4060	300	4350	3000	400
2PE - 19	19.4	1.15	220	3190	240	3480	260	3750	3000	400
2PE - 22.5	22.9	1.37	200	2900	220	3190	240	3480	2750	400
2PE - 26	25.8	1.58	180	2610	200	2900	220	3190	2500	400

*Available only as rear pump

	Displacement		Continuous pressure P ^{1**}		Intermittent pressure P ²		Peak pressure P ³		Max. speed	Min. speed
	cm ³ /rev	cu.in/rev	bar	psi	bar	psi	bar	psi		
GROUP 2.5 - B SERIES										
2.5PB - 5.5*	5.97	0.36	250	3625	280	4060	300	4350	3000	600
2.5PB - 8.3*	8.29	0.50	250	3625	280	4060	300	4350	3000	600
2.5PB - 11.5*	11.76	0.72	250	3625	280	4060	300	4350	3000	600
2.5PB - 13.8*	14.07	0.86	250	3625	280	4060	300	4350	3000	600
2.5PB - 16	16	0.97	250	3625	280	4060	300	4350	3000	600
2.5PB - 19	19.3	1.17	250	3625	280	4060	300	4350	3000	600
2.5PB - 22	22.2	1.35	250	3625	280	4060	300	4350	3000	500
2.5PB - 25	25.2	1.53	250	3625	280	4060	300	4350	3000	500
2.5PB - 28	27.6	1.68	250	3625	280	4060	300	4350	3000	500
2.5PB - 32	32.4	1.97	230	3335	250	3625	260	3750	3000	500
2.5PB - 38	38.1	2.32	200	2900	220	3190	240	3480	2750	400
2.5PB - 44	44.2	2.69	170	2465	190	2755	210	3040	2500	400

*Available only as rear pump. Displacements 11.5-13.8 are available as single pump only with drive shaft “55”.



	Displacement		Continuous pressure P ^{1**}		Intermittent pressure P ²		Peak pressure P ³		Max. speed	Min. speed
	cm ³ /rev	cu.in/rev	bar	psi	bar	psi	bar	psi		
GROUP 3 - E SERIES									min ⁻¹	
3PE - 21*	20.6	1.26	250	3625	280	4060	300	4350	3000	600
3PE - 27	27	1.65	250	3625	280	4060	300	4350	3000	600
3PE - 33	33.5	2.04	250	3625	280	4060	300	4350	3000	600
3PE - 38	38.7	2.36	250	3625	280	4060	300	4350	2750	500
3PE - 46	46.9	2.86	250	3625	270	3915	280	4060	2750	500
3PE - 55	54.1	3.3	220	3190	240	3480	250	3625	2500	400
3PE - 65	63.1	3.85	200	2900	220	3190	240	3480	2500	400
3PE - 75*	73.4	4.48	180	2610	200	2900	220	3190	2500	400

*Displacements 21 and 75 are special release, please contact sales department.

	Displacement		Continuous pressure P ^{1**}		Intermittent pressure P ²		Peak pressure P ³		Max. speed	Min. speed
	cm ³ /rev	cu.in/rev	bar	psi	bar	psi	bar	psi		
GROUP 3.5 - C SERIES									min ⁻¹	
3.5PC - 55	54.8	3.34	250	3625	280	4060	300	4350	2750	400
3.5PC - 64	63.2	3.85	250	3625	280	4060	300	4350	2750	350
3.5PC - 75	74.7	4.55	230	3335	250	3625	280	4060	2500	300
3.5PC - 87	88	5.36	210	3040	230	3330	260	3750	2250	300
3.5PC - 98*	99	6.03	200	2900	220	3190	250	3625	2000	300

*Displacement 98 are special release, please contact sales department.

**For working conditions, using exclusively pressure P¹, the value of max. speed must be reduced of 10%.

For bidirectional pump the max pressure has to be reduced of 10%.

The max pressure is referred to pumps with flanged ports, using the threaded ports the pump life could be reduced.

ROTATION CHANGING INSTRUCTIONS FOR UNITS

Before starting, be sure that the pump is cleaned externally as well as the working area to avoid that particles dangerous for pump working can find their way into the pump. Pump represented is a clockwise rotation pump.

To obtain an anti_clockwise rotation read carefully the following instructions.

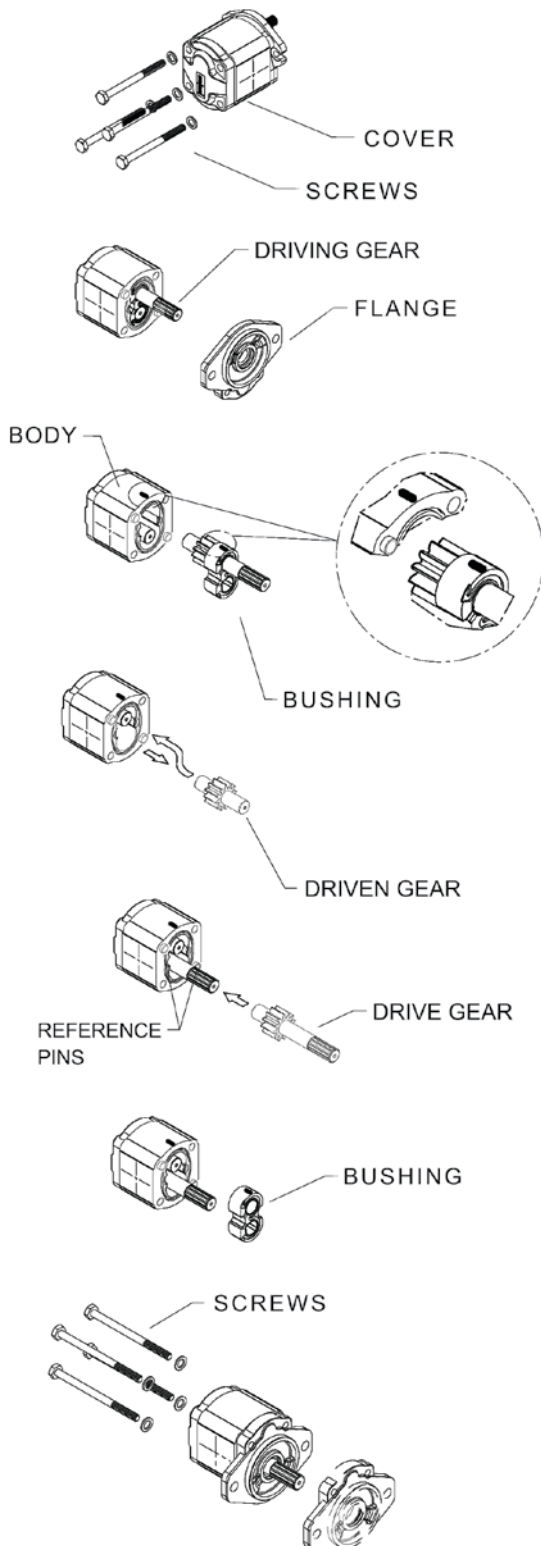

- 1 - Loosen and fully unscrew the screws.
- 2 - Lay the pump on the working area in order to have the mounting flange turned upside.
- 3 - Coat the shaft extension with grease to avoid damaging the shaft seal.
- 4 - Remove the flange and lay it on the working area; verify that the seal is correctly located in the body seat.

- 1 - Mark the position of the bushing and eventually the thrust plate, relative to the body.
- 2 - Remove the bushing, thrust plate and the driving gear taking care to avoid driven gear axial shifts.

- 1 - Draw out the driven gear from its housing, taking care to avoid rear cover axial shifts.
- 2 - Re-locate the driven gear in the position previously occupied by the driving gear.

- 1 - Re-locate the driving gear in the position previously occupied by the driven gear.

- 1 - Replace the bushing and thrust plate taking care that:
 - marks are located as on the picture
 - surface containing the seal is visible
 - seal and its protection are correctly located

- 1 - Clean body and mounting flange refaced surfaces.
- 2 - Verify that the two plugs are located in the body.
- 3 - Refit the mounting flange, turned 180° from its original position.
- 4 - Replace the clamp bolts and tighten crosswise evenly to a torque you will find at page 8.
- Check that the shaft rotates freely.
- 6 - Mark on the flange the new direction of rotation.

INDEX

Shafts And Flanges Combination	33
Assembling Dimensions And Working Conditions	34
Flanged And Threaded Ports.....	35
Drive Shafts	36
Mounting Flanges	38
Outrigger Bearing	41
Rear Covers	45
High-Low Multiple Pump.....	47
Pressure Compensated Priority Flow Valve	48
Load Sensing Priority Valve.....	49
Electric Unloading Valve	50
Multiple Gear Pumps Assembling Dimensions.....	51
2PE Combination With Pump 1.5PE	52
Performance Curves.....	53
How To Order Single Pumps	60
How To Order Multiple Pumps.....	61

Final revised edition-April 2017











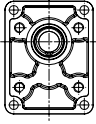
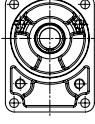

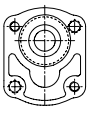
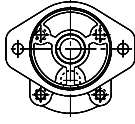

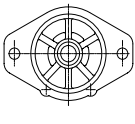
The data in this catalogue refers to the standard product.

The policy of Salami S.p.A. consists of a continuous improvement of its products. It reserves the right to change the specifications of the different products whenever necessary and without giving prior information.

If any doubts, please get in touch with our sales department.



SHAFTS AND FLANGES COMBINATION

2PE							
	CODE P1 European Standard	CODE B1 German Standard	CODE B2-B3 German Standard	CODE B4-B5 German Standard	CODE S2 SAE A 2 Bolts	CODE C1 4 Bolts Iveco	CODE S3 SAE B 2 Bolts
 CODE 25 Tapered 1:5		25B1		25B4 25B5			
 CODE 28 Tapered 1:8	28P1						
 CODE 03 Tang drive for electric motors			03B2 03B3				
 CODE 04 Tang drive				04B4 04B5			
 CODE 62 DIN 5482 splined 9 T	62P1	62B1		62B4 62B5		62C1	
 CODE 52 SAE A splined 9T					52S2		
 CODE 54 SAE A splined 11T					54S2		
 CODE 55 SAE B splined 13T							55S3
 CODE 85 SAE A parallel shaft Ø19.05					85S2		
 CODE 82 SAE A parallel shaft Ø15.87	82P1				82S2		

Note: other versions available, see shafts and flanges information.



Displacements up to 1.58 cu.in./rev
Pressure up to 4350 psi



GEAR PUMPS

Displacements up to 25.8 cm³/rev
Pressure up to 300 bar

ASSEMBLING DIMENSIONS AND WORKING CONDITIONS

Type		3.2*	3.9*	4.5	6.5	8.3	10.5	11.3	12.5	13.8	16	19	22.5	26	
Displacement	cm ³ /rev	3.2	3.9	4.6	6.5	8.2	10.6	11.5	12.7	13.8	16.6	19.4	22.9	25.8	
	cu.in./rev	0.19	0.24	0.27	0.40	0.50	0.65	0.68	0.77	0.84	1.01	1.15	1.37	1.58	
Dimension A	mm	47.1			49.95	52.8	56.3	59.7		63.5	67.5	75.6	81	86.8	
	in	1.83			1.97	2.07	2.22	2.35		2.5	2.65	2.97	3.19	3.42	
Dimension C	mm	23.55			25	26.4	28.15	29.75		31.75	33.75	37.80	40.5	43.4	
	in	0.93			0.98	1.04	1.11	1.17		1.25	1.33	1.49	1.59	1.71	
Continuous pressure	P ¹	bar	250	250	250	250	250	250	250	250	250	220	200	180	
		psi	3625	3625	3625	3625	3625	3625	3625	3625	3625	3625	3190	2900	2610
Intermittent pressure	P ²	bar	280	280	280	280	280	280	280	280	280	240	220	200	
		psi	4060	4060	4060	4060	4060	4060	4060	4060	4060	4060	3480	3190	2900
Peak pressure	P ³	bar	300	300	300	300	300	300	300	300	300	260	240	220	
		psi	4350	4350	4350	4350	4350	4350	4350	4350	4350	4350	3750	3480	3190
Max speed at	P ²	rpm	4000	4000	4000	4000	3500	3500	3500	3500	3000	3000	2750	2500	
Min speed at	P ¹	rpm	600	600	600	600	500	500	500	500	400	400	400	400	
Weight		kg	3.00	3.05	3.10	3.50	3.60	3.70	3.75	3.78	3.86	4.00	4.18	4.29	4.54
		lbs	6.61	6.72	6.83	7.72	7.94	8.16	8.27	8.33	8.51	8.82	9.22	9.46	10.1

*Available only as rear pump

For flanges code:

P1-B1-S2-S6, this dimension is 19 mm (0.75 in.)

B2-B3-B4-B5, this dimension is 16.5 mm (0.65 in.)

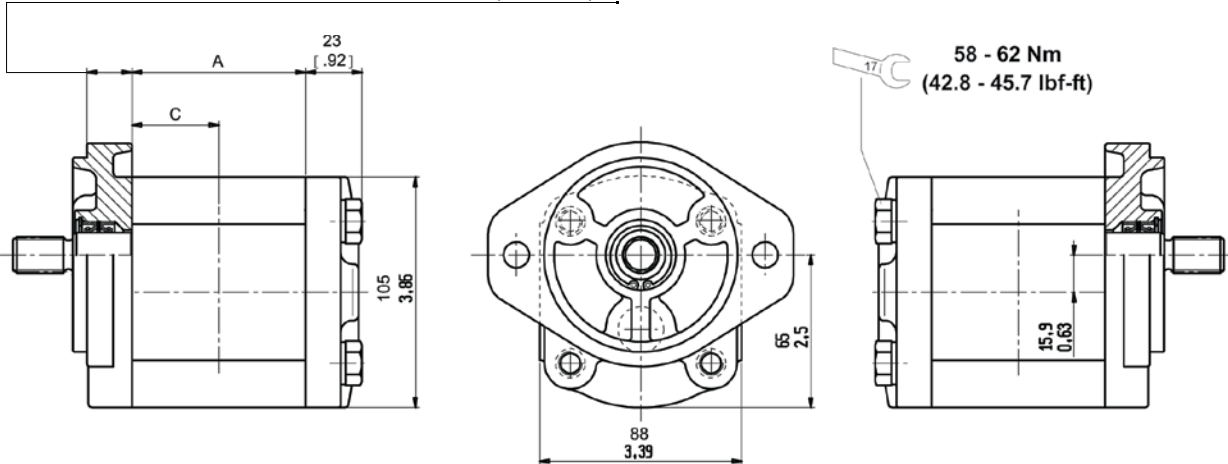

E0.120.0417.02.00IM03



FLANGED AND THREADED PORTS

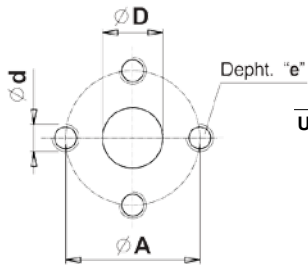

code P

Flanged ports
european standard

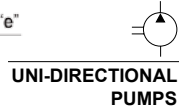

TYPE	INLET				OUTLET			
	Ø D	Ø A	d	e	Ø D	Ø A	d	e
From 3.2 to 8.3	13 (0.51")	30 (1.19")	M6	13 (0.51")	13 (0.51")	30 (1.18")	M6	13 (0.51")
From 11.3 to 22.5	20 (0.79")	40 (1.57")	M8					
26	22 (0.87")							



BI-DIRECTIONAL PUMPS Special version available on request.

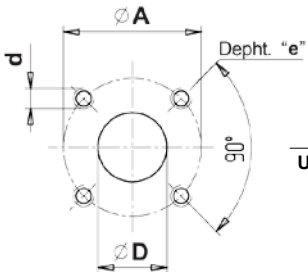

code B

Flanged ports
german standard



TYPE	INLET				OUTLET			
	Ø D	Ø A	d	e	Ø D	Ø A	d	e
From 3.2 to 22.5	20 (0.78")	40 (1.56")	M6	13 (0.51")	15 (0.59")	35 (1.38")	M6	13 (0.51")
26	22 (0.87")							



BI-DIRECTIONAL PUMPS Special version available on request.

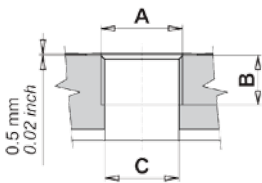

code G

Threaded ports
GAS (BSPP)



TYPE	INLET			OUTLET		
	A	B	ØC	A	B	ØC
From 3.2 to 26	G3/4	16 (0.62")	20 (0.78")	G1/2	14 (0.54")	13 (0.51")



BI-DIRECTIONAL PUMPS Special version available on request.

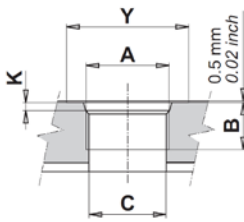

code R

Threaded ports
SAE (ODT)



TYPE	INLET					OUTLET				
	A	B	ØC	Y	K	A	B	ØC	Y	K
From 3.2 to 26	1-1/16-12 UN (SAE 12)	16 (0.62")	20 (0.78")	41 (1.61")	3.3 (0.12")	7/8-14 UNF (SAE 10)	14 (0.54")	13 (0.78")	34 (1.32")	2.5 (0.10")



BI-DIRECTIONAL PUMPS Special version available on request.

EO.120.0417.02.001M03



DRIVE SHAFTS

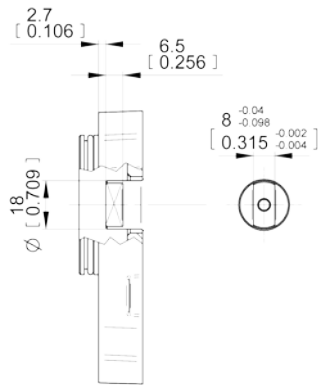

code 03 Max torque 70 Nm (620 lbf in)
Tang drive for electric motors
Without shaft seal

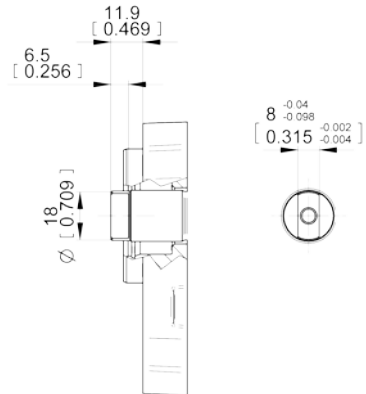

code 04 Max torque 70 Nm (620 lbf in)
Tang drive

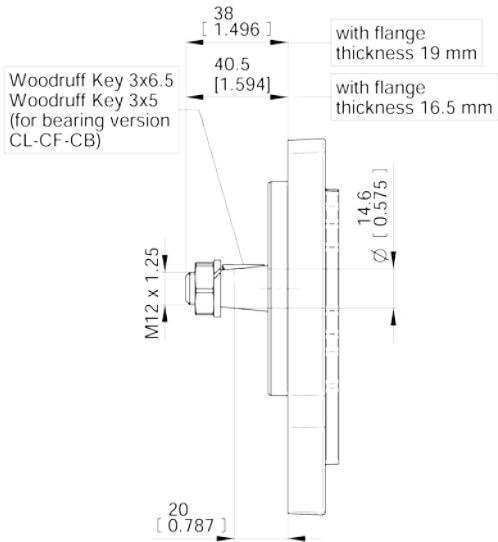

code 25 Max torque 130 Nm (1151 lbf in)
Tapered 1:5

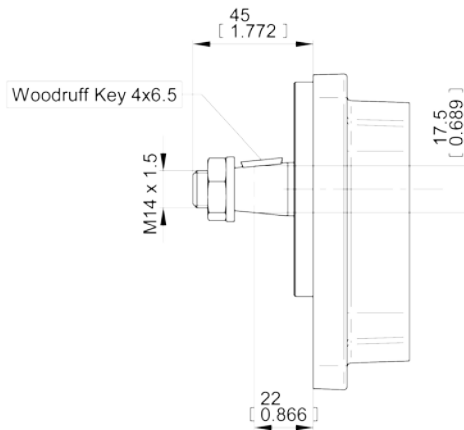

code 26 Max torque 100 Nm (885 lbf in)
Tapered 1:5 (only for CB)

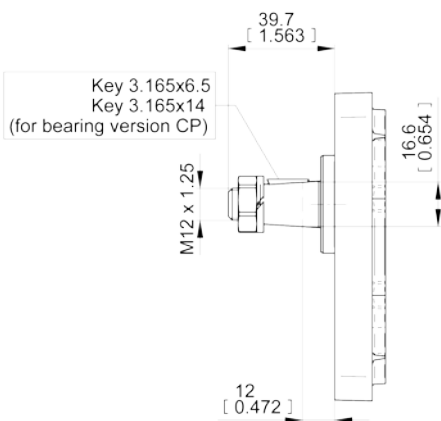

code 28 Max torque 130 Nm (1151 lbf in)
Tapered 1:8

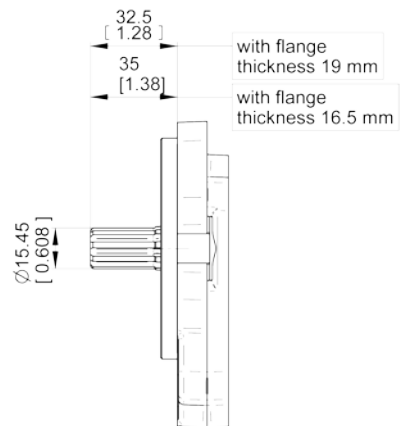

code 52 Max torque 100 Nm (885 lbf in)
SAE A 9T-16/32DP Ansi B92 1a 1976

E0.120.0417.02.00IM03



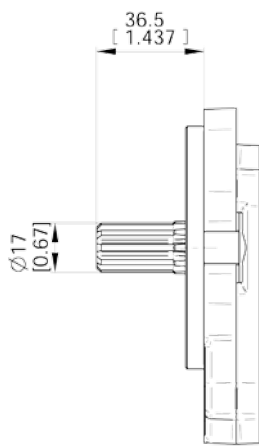

code 53 Max torque 125 Nm (1106 lbt in)

SAE A 10T-16/32DP Ansi B92 1a 1976

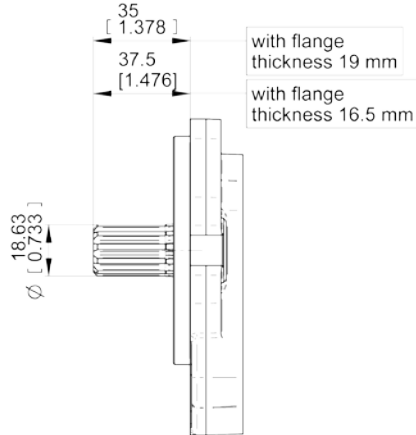

code 54 Max torque 150 Nm (1327 lbt in)

SAE A 11T-16/32DP Ansi B92 1a 1976

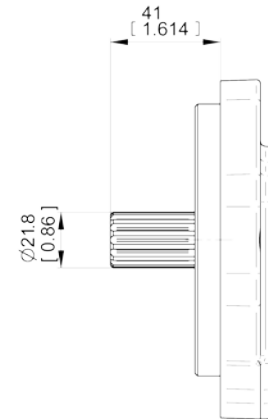

code 55 Max torque 100 Nm (885 lbt in)

SAE B 13T-16/32DP Ansi B92 1a 1976

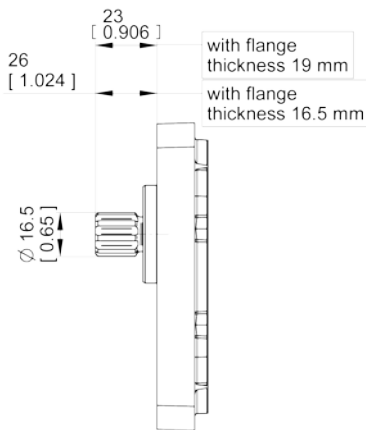

code 62 Max torque 120 Nm (1062 lbt in)

9 teeth DIN 5482 splined

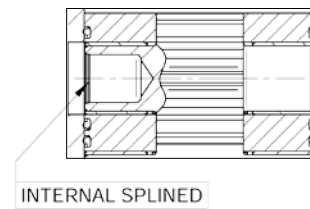

code 60 Max torque 100 Nm (885 lbt in)

**DIN 5480 internal splined
(only for rear pumps)**

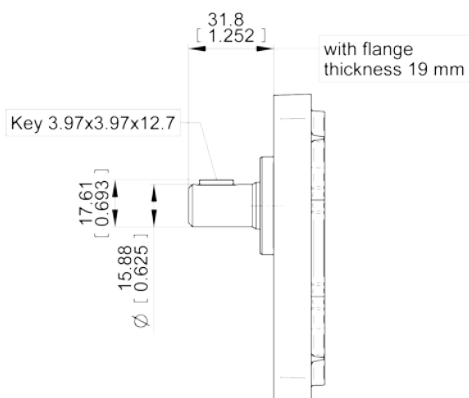

code 82 Max torque 70 Nm (620 lbt in)

5/8" SAE A parallel

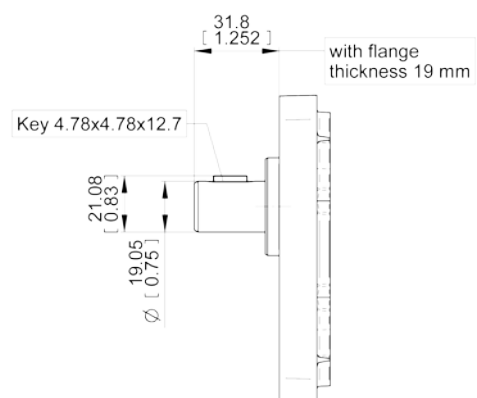

code 85 Max torque 130 Nm (1151 lbt in)

3/4" SAE A parallel

EO.120.0417.02.001M03



MOUNTING FLANGES

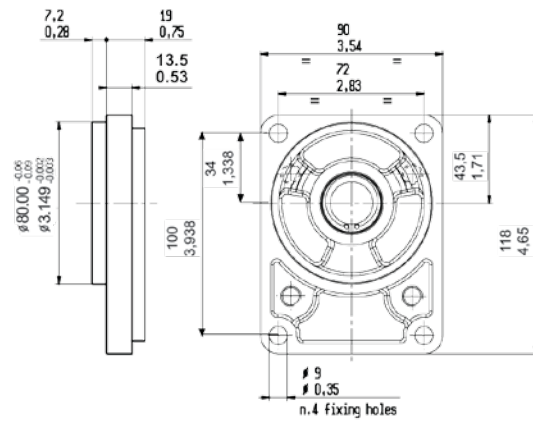
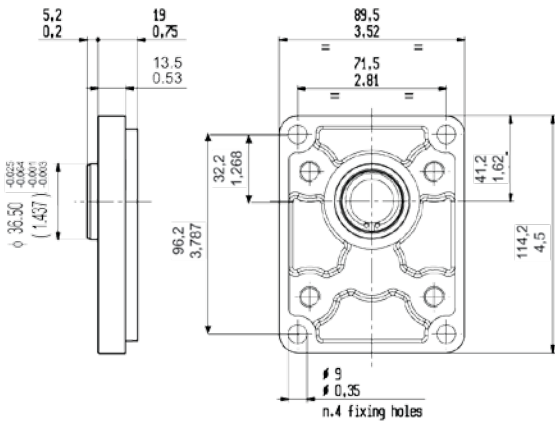

P1 European standard

With shaft code 28-62-82

B1 German standard

With shaft code 25-62

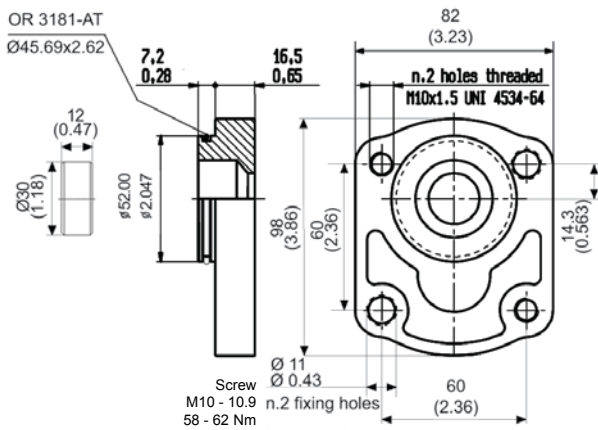

B2 German standard

With shaft code 03

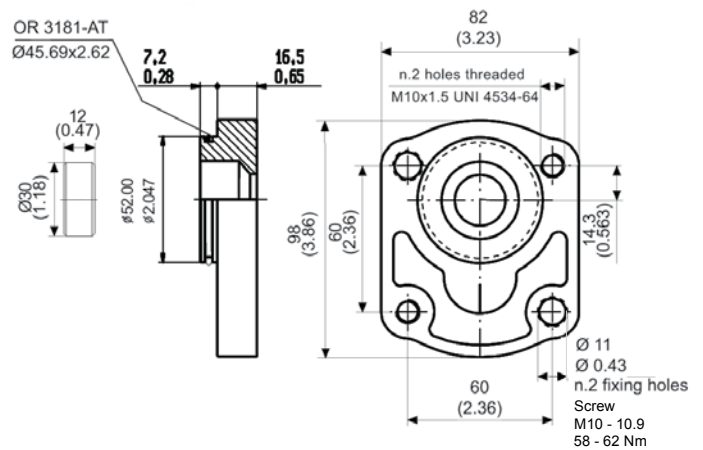

B3 German standard

With shaft code 03

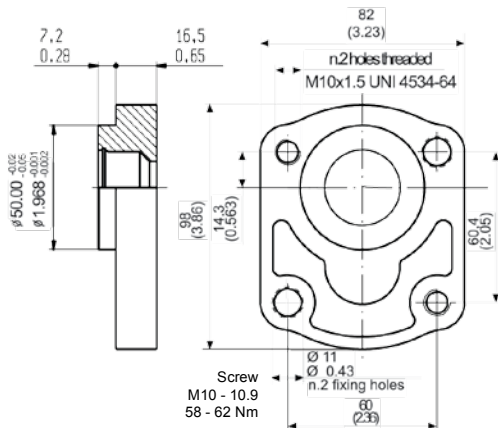

B4 German standard

With shaft code 25-62-04

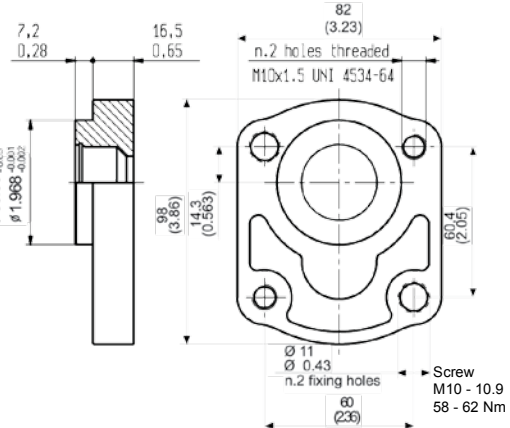

B5 German standard

With shaft code 25-62-04

E0.120.0417.02.00IM03



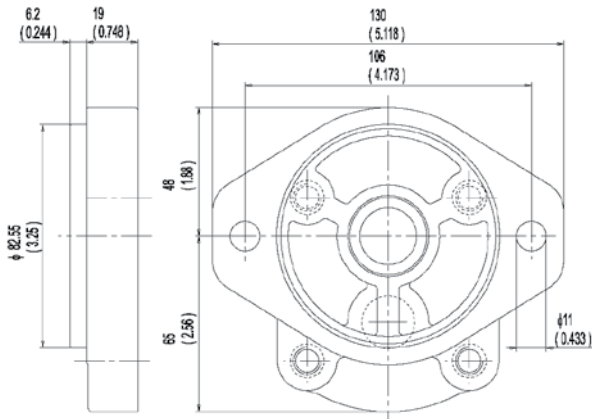

S2

SAE A 2 bolts

With shaft code 52-53-54-82-85

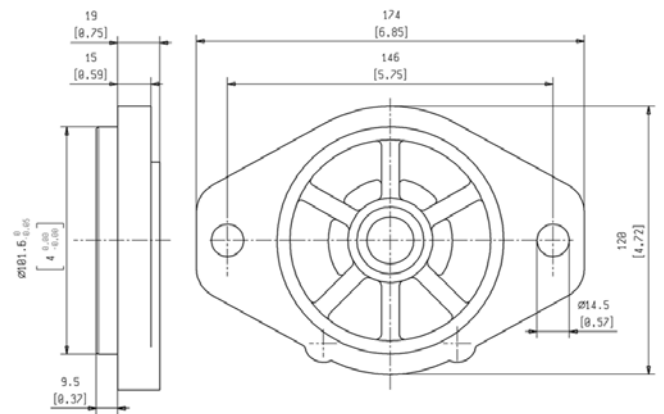

S3

SAE B 2 bolts

With shaft code 55

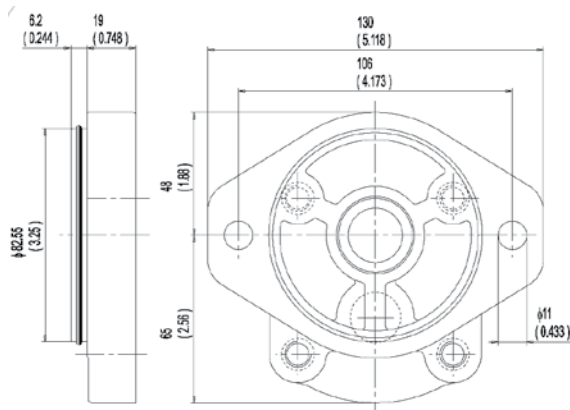

S6

SAE A 2 bolts
(with O-ring on the centering collar)

With shaft code 52-54-82-85

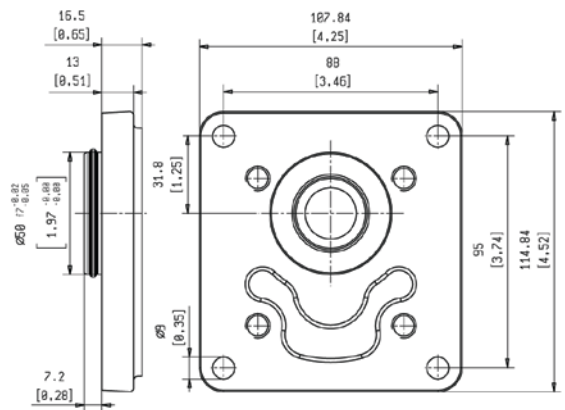

C1

4 bolts for Iveco engines

With shaft code 62

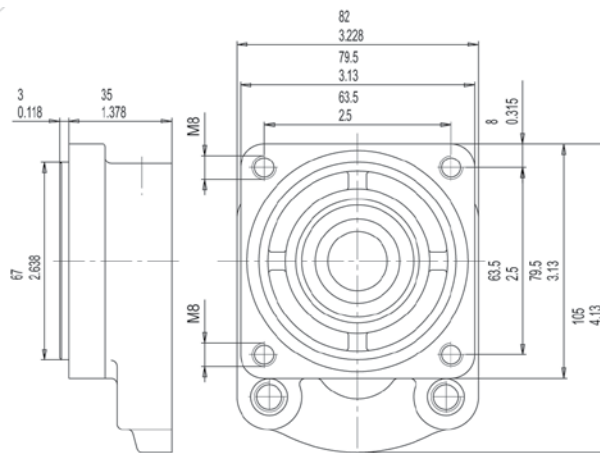

K1

4 bolts for Perkins Motor

With shaft code 02

EO.120.0417.02.001M03

OUTRIGGER BEARING

The following diagrams show radial load capability of the bearing.

Calculation according to ISO 281 at 10 cSt.

TYPE	H
4.5	47.1 (1.83")
6.5	49.95 (1.97")
8.3	52.8 (2.08")
10.5	56.3 (2.22")
11.3-12.5	59.7 (2.35")
13.8	63.5 (2.5")
16	67.5 (2.66")
19	75.6 (2.97")
22.5	81 (3.19")
26	86.6 (3.42")

L=Distance between mounting flange and radial force point of application.

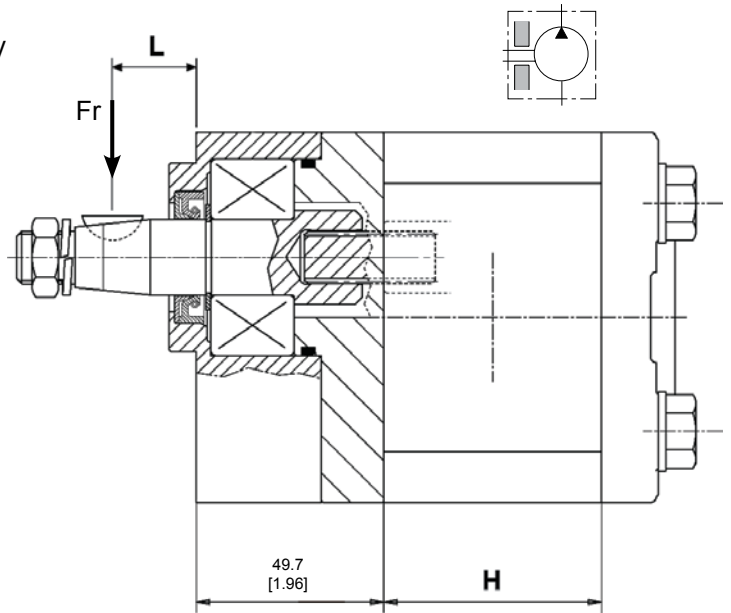

Example:

Fr = 1700 N

L = 7.5

Speed = 2000 rpm

→ Expected life: 1000 hrs

For Code CP-CB-CL-CS

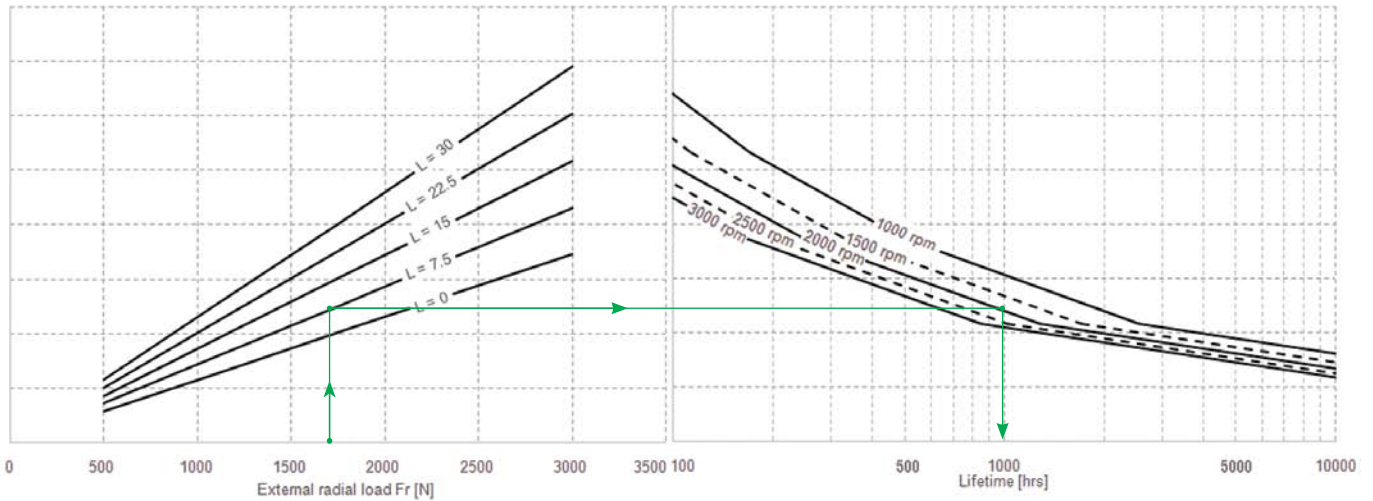

For Code CF

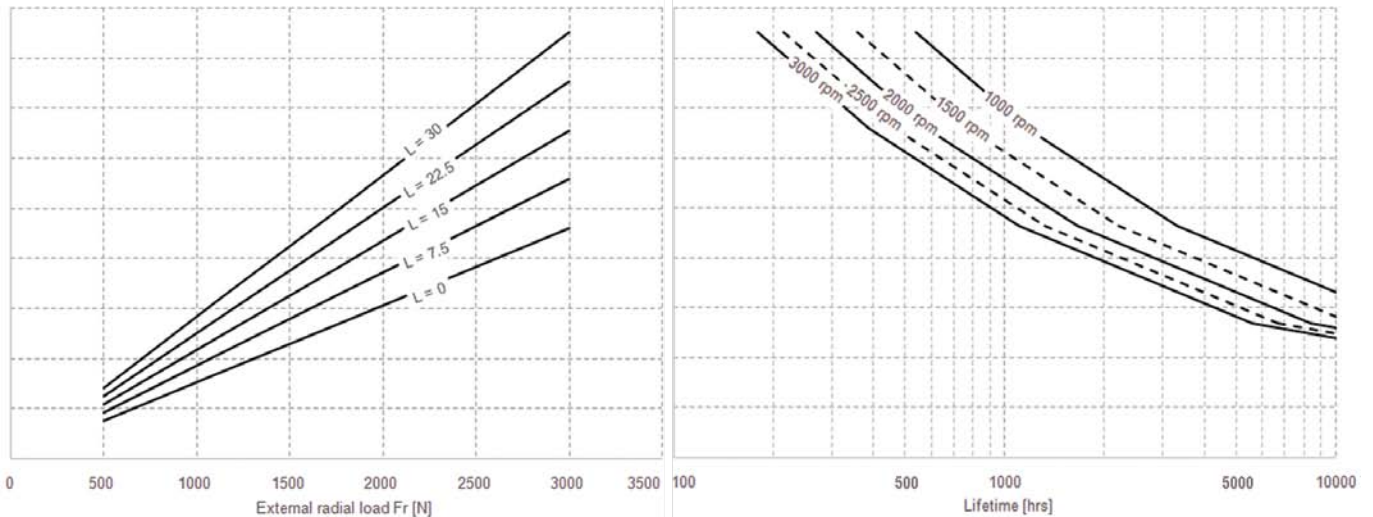

EO.120.0417.02.001M03



ALUMINIUM MOUNTING FLANGES
WITH BEARING

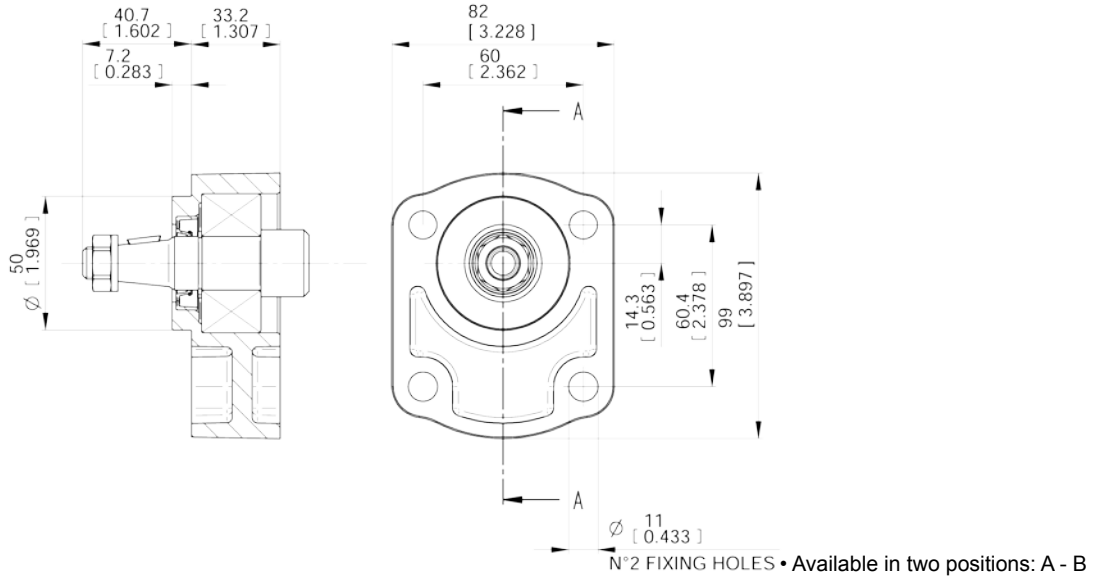

CL	For engine endothermic motors
With shaft code 25, 26	

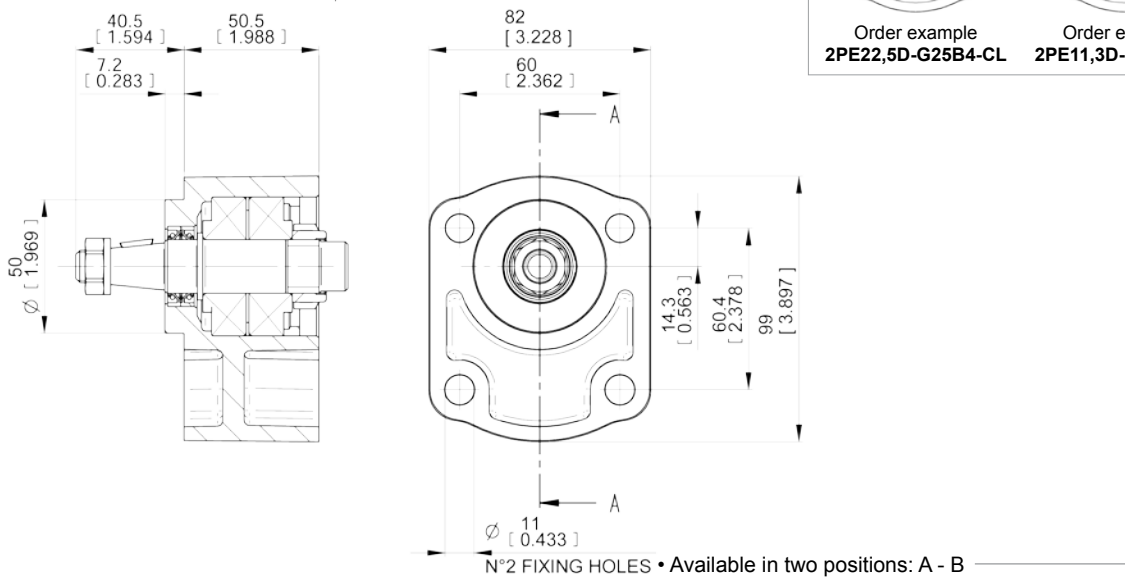
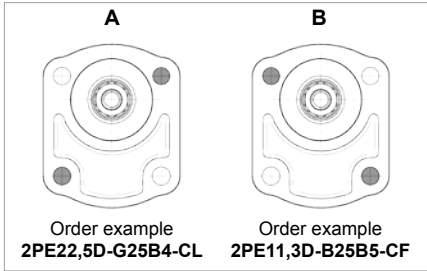

CF	For endothermic motors
With shaft code 25-26	

E0.120.0417.02.00IM03



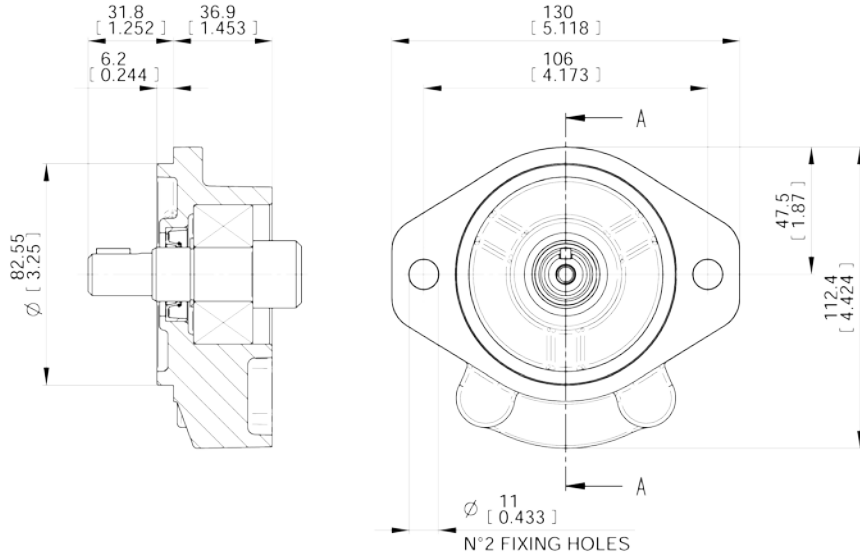

CS	SAE A
With shaft code 52-54-82-85	

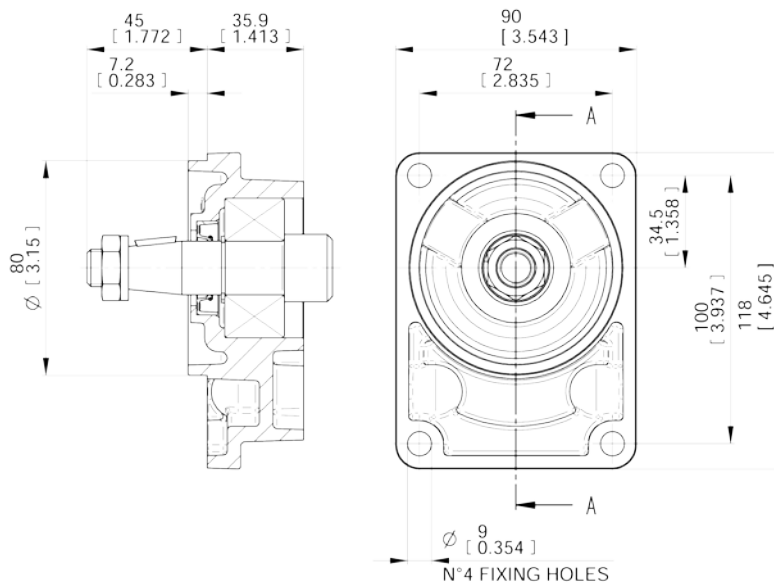

CB	German standard
With shaft code 25-26	

EO.120.0417.02.001M03



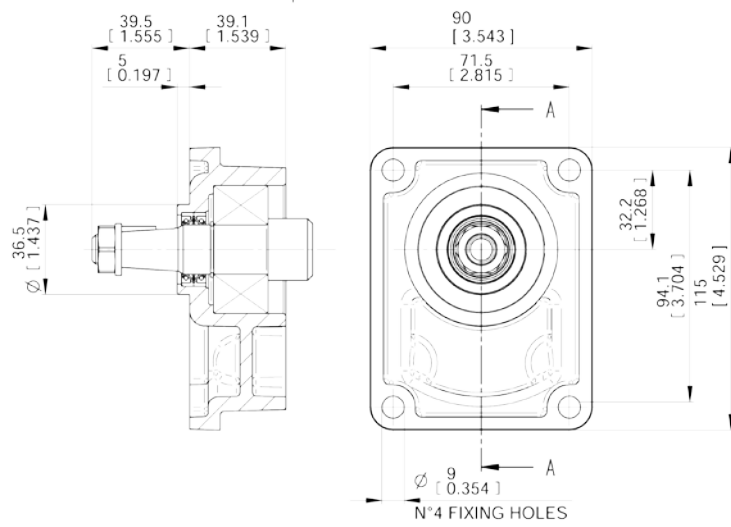

CP	European standard
With shaft code 28	

REAR COVERS

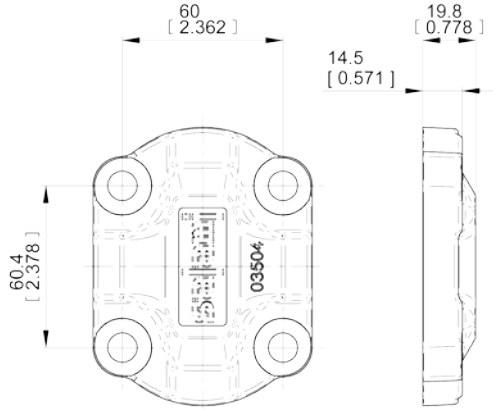

STANDARD REAR COVER

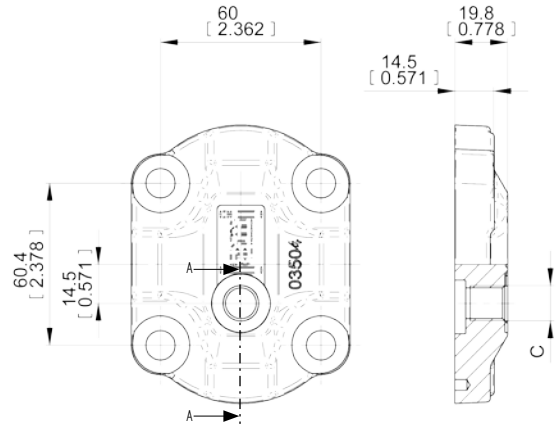

STANDARD REAR COVER WITH EXTERNAL DRAIN C FOR BIDIRECTIONAL PUMPS

C
7/16-20 UNF-2B (SAE4)
G1/4

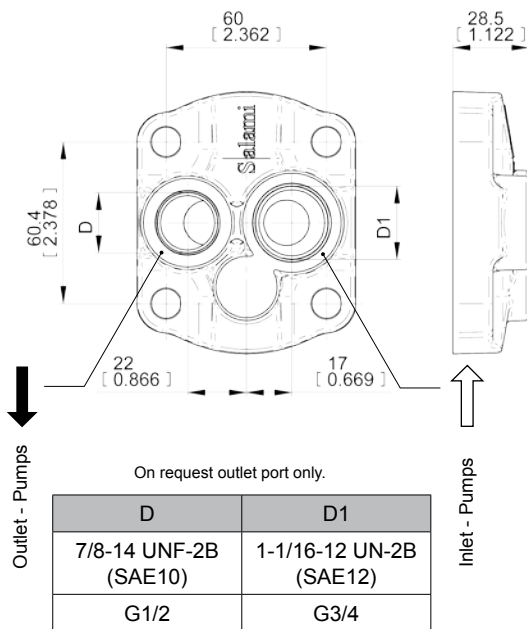

code 1 REAR COVER WITH REAR PORTS

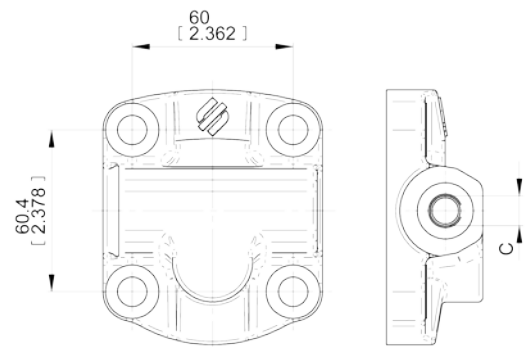

C
7/16-20 UNF-2B (SAE4)
G1/4

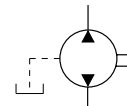

code LD REAR COVER WITH LATERAL DRAIN

EO.120.0417.02.001M03



REAR COVERS WITH VALVE

code VS INTERNAL DISCHARGE

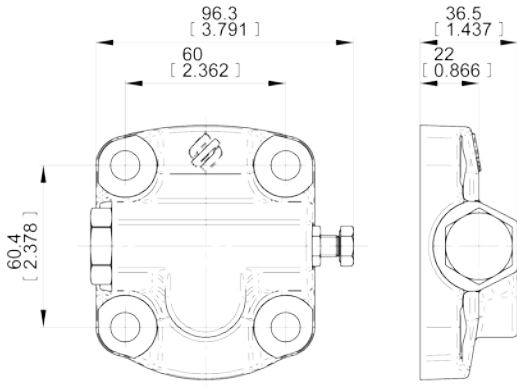

MAIN RELIEF VALVE
setting ranges
30-60 bar
61-120 bar
121-170 bar
171-250 bar

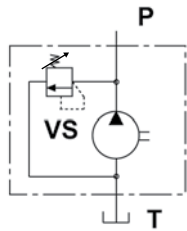

code VSE EXTERNAL DISCHARGE

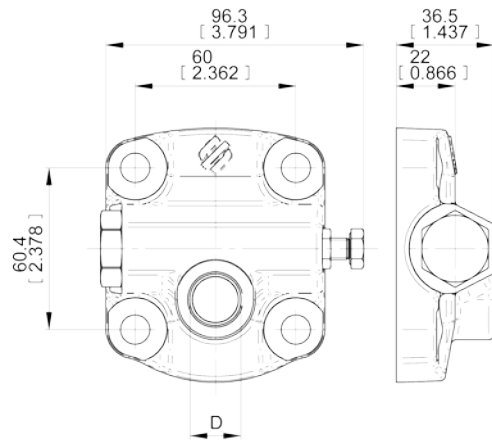

D (external discharge)
M18x1.5 (METRIC)
3/4-16 UNF-2B (SAE 8)
G3/8 (BSPP)

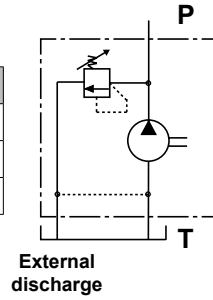

code IDV REAR COVERS WITH INTERNAL DRAIN

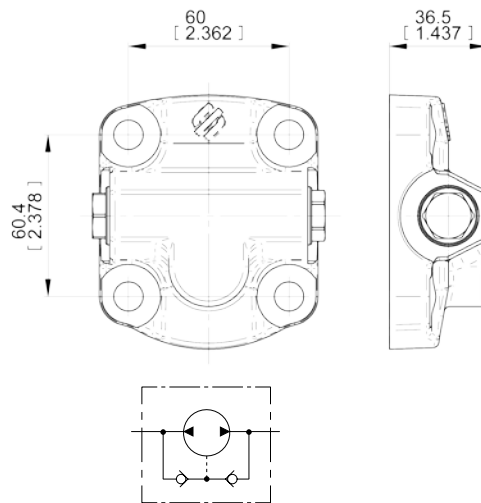

E0.120.0417.02.00IM03



HIGH-LOW MULTIPLE PUMP

High-Low Multiple Pump is the very ideal pump for applications which require a quick approach and/or return of the actuator at low loads and slow motion of the actuator at high loads. This model offers the advantage of requiring lower power of the motor. High-Low Multiple Pumps is a special double stage pump with integrated valves and has been specially designed for applications such as trash compactors, log splitters, clamping mechanisms, crimping machines, metal forming machines etc.

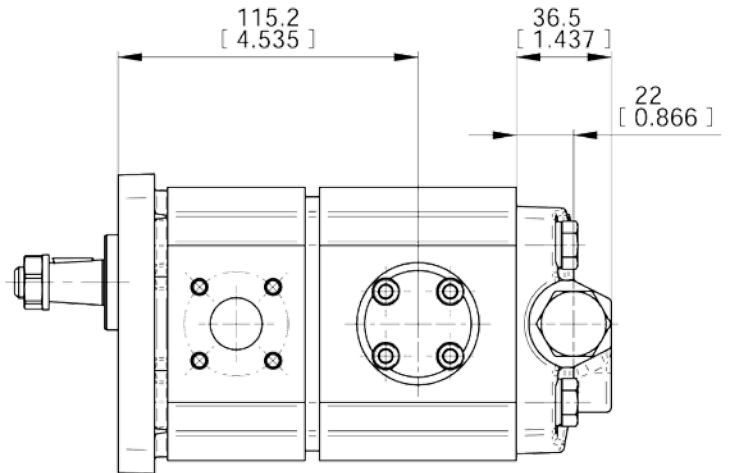
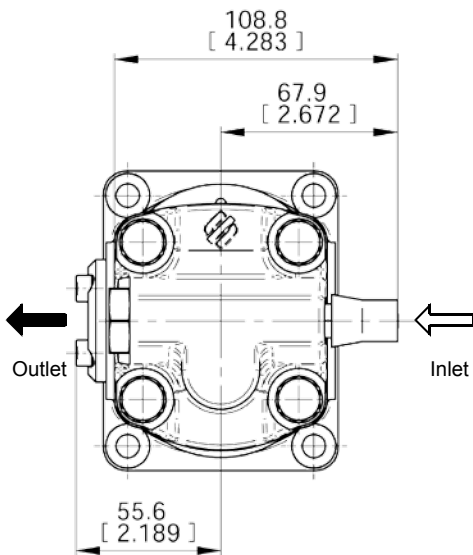

code VSQ

For this Unloading valve you can choose four setting ranges:

- (30-60 bar)
- (60-120 bar)

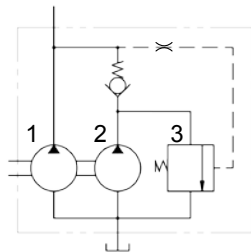

1_Stage high pressure
2_Stage low pressure
3_Unloading valve

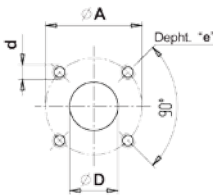
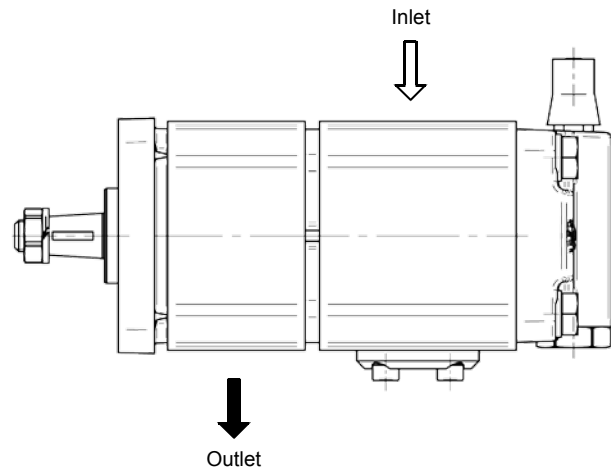

code B

Flanged ports
german standard

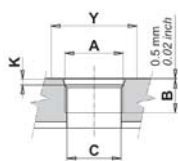

code R

Threaded ports
SAE (ODT)

REAR STAGE LOW PRESSURE					FIRST STAGE HIGH PRESSURE				
TYPE	INLET				TYPE	OUTLET			
	Ø D	Ø A	d	e		Ø D	Ø A	d	e
From 8.3 to 19	20 (0.78")	40 (1.56")	M6	13 (0.51")	From 4.5 to 6.5	15 (0.59")	35 (1.38")	M6	13 (0.51")
From 22 to 26	22 (0.87")	55 (2.16")	M8		From 8.3 to 16	20 (0.78")	40 (1.56")		

REAR STAGE LOW PRESSURE						FIRST STAGE HIGH PRESSURE					
TYPE	INLET					TYPE	OUTLET				
	A	B	ØC	Y	K		A	B	ØC	Y	K
From 8.3 to 26	1-5/16 12 UN (SAE16)	16 (0.62")	20 (0.78")	41 (1.61")	3.3 (0.12")	From 4.5 to 16	7/8-14 UNF (SAE 10)	14 (0.54")	13 (0.78")	34 (1.32")	2.5 (0.10")

EO.120.0417.02.001M03



PRESSURE COMPENSATED
PRIORITY FLOW VALVE

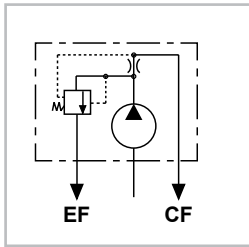

code VP

code VP1

Priority flow valve, excess flow to second actuator.

CF = Priority flow port
EF = Excess flow port

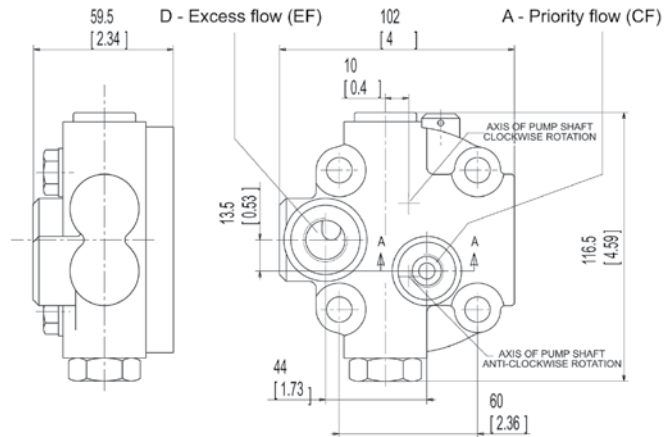

VP - VPS
REAR PORTS

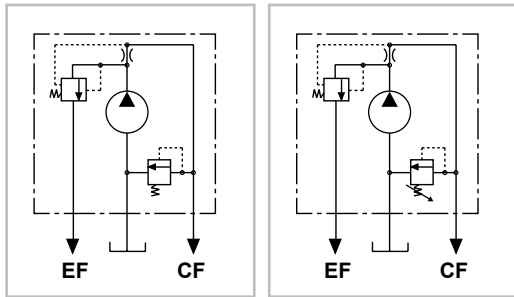

code VPS

code VPS1

Priority flow valve, excess flow to second actuator with pressure relief valve on priority flow line.

A	D
G 3/8	G 1/2
SAE6 9/16-18 UNF-2B	SAE8 3/4 - 16 UNF - 2B

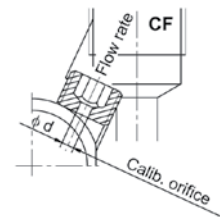

Det. SECT.A-A

CALIBRATED ORIFICE Φ d (mm/inch)	FLOW RATE (l/min - gpm) ± 10%
1.5 / (0.06")	2.5 - (0.66)
2 / (0.08")	4 - (1.06)
2.4 / (0.09")	6 - (1.59)
2.8 / (0.11")	8 - (2.11)
3.1 / (0.12")	10 - (2.64)
3.5 / (0.14")	12.5 - (3.30)
4 / (0.16")	16 - (4.23)
4.4 / (0.17")	20 - (5.28)
4.9 / (0.19")	25 - (6.61)

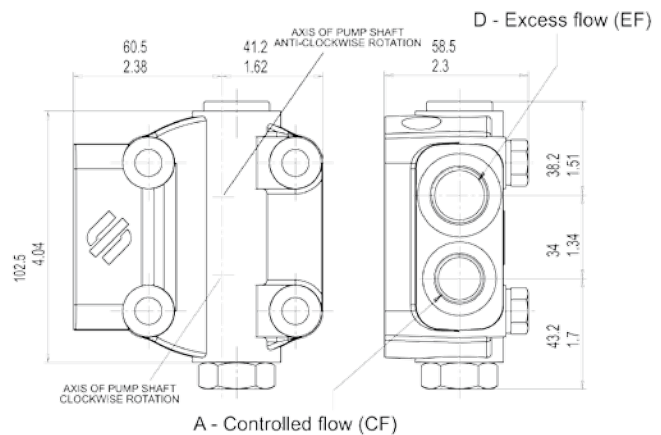

VP1 - VPS1
SIDE PORTS

PRIORITY FLOW VALVE (VP - VPS)

3 Ways flow control priority valve. It ensures a constant flow to CF port, given by the screwed control orifice (see table) and regardless of the pump speed; the excess flow is available for other functions at the EF port.

The two lines CF and EF can be loaded simultaneously and the max pressure of the priority line can be limited by a relief valve connected to the suction port.

A	D
G 3/8	G 1/2
SAE8 3/4 - 16 UNF - 2B	SAE10 7/8 - 14 UNF - 2B

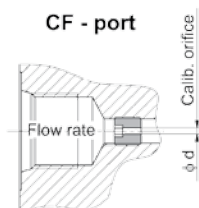

E0.120.0417.02.00IM03



LOAD SENSING PRIORITY VALVE

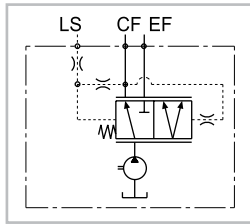

code VPD

code VPD1

Load sensing priority valve with dynamic signal without main relief valve.

CF = Priority flow port
EF = Excess flow port
LS = Load sensing signal port

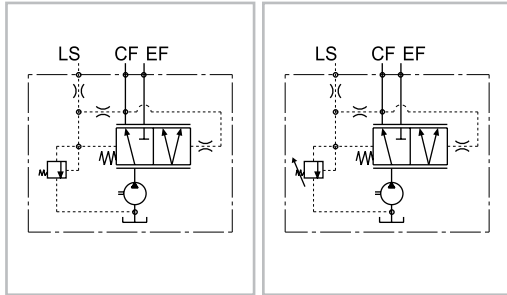

code VPDS

code VPDS1

Load sensing priority valve with dynamic signal with main relief valve.

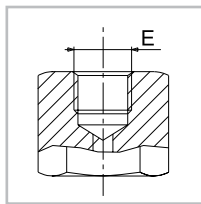

Female fitting

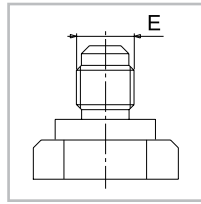

Male fitting

LOAD SENSING PRIORITY VALVES
(VPD1-VPDS1)

The load sensing priority valve is a control valve able to divide the flow generated by the pump, coming from the port P, in two different flows named Qcf and Qef.

The Qcf flow follows the user request, the flow Qef changes according to the equation:

$$Q_{in} = Q_{cf} + Q_{ef}$$

This valve is used in hydraulic steering systems, the CF port is connected to the inlet of power steering unit while the other functions (lifter etc...) are connected to the EF port. The load sensing LS signal of the valve is connected to the LS of powersteering unit.

The regulated flow Qcf depends on the steering speed, the remaining flow Qef is available for the other functions and complies with the equation

$$Q_{ef} = Q_{in} - Q_{cf}$$

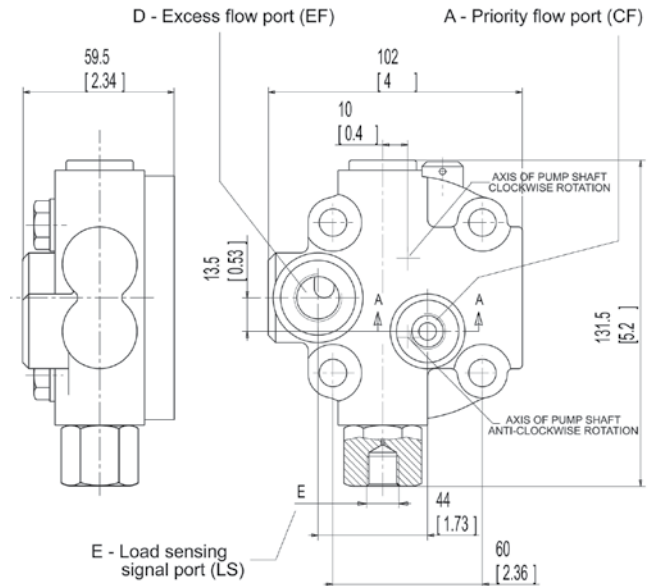

VPD - VPDS
REAR PORTS Minimum load sensing signal (LS) = 4 bar (28 psi)

A	D	E
G 3/8	G 1/2	G 1/4
SAE6 9/16 - 18 UNF - 2B	SAE8 3/4 - 16 UNF - 2B	SAE4 7/16 - 20 UNF - 2B

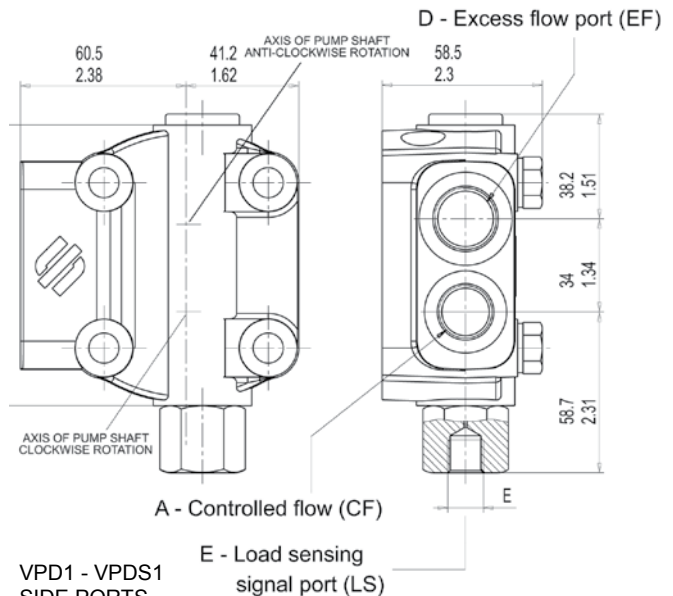

VPD1 - VPDS1
SIDE PORTS

Minimum load sensing signal (LS) = 4 bar (28 psi)

A	D	E
G 3/8	G 1/2	G 1/4
SAE8 3/4 - 16 UNF - 2B	SAE10 7/8 - 14 UNF - 2B	SAE4 7/16 - 20 UNF - 2B

EO.120.0417.02.001M03



ELECTRIC UNLOADING VALVE

code EV

EV1 - 12 Vcc
EV2 - 24 Vcc

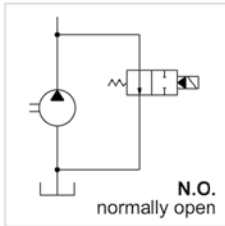

EV3 - 12 Vcc
EV4 - 24 Vcc

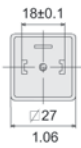
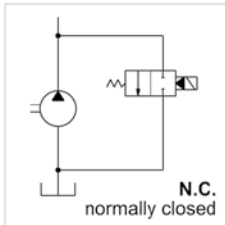

CONNECTOR
DIN 43650
A/ISO 4400

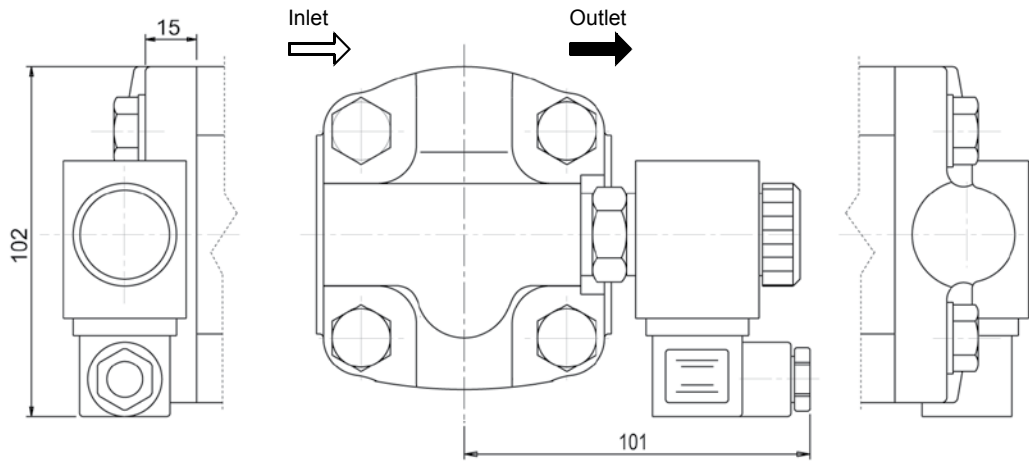
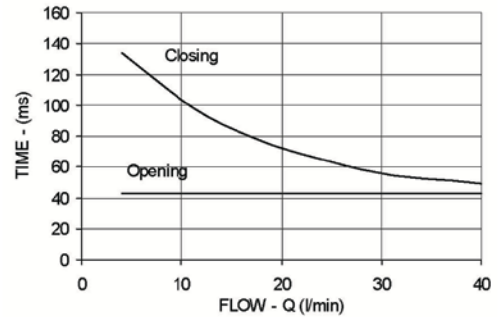
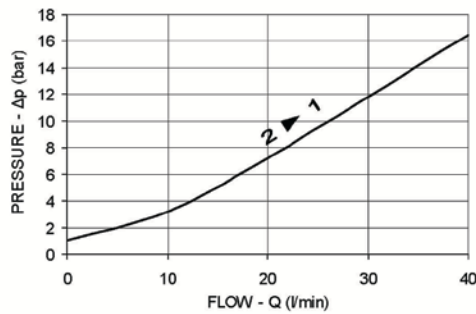

code EVS

EVS1 - 12 Vcc
EVS2 - 24 Vcc

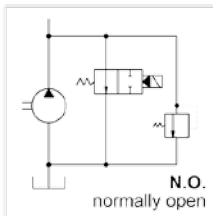

EVS3 - 12 Vcc
EVS4 - 24 Vcc

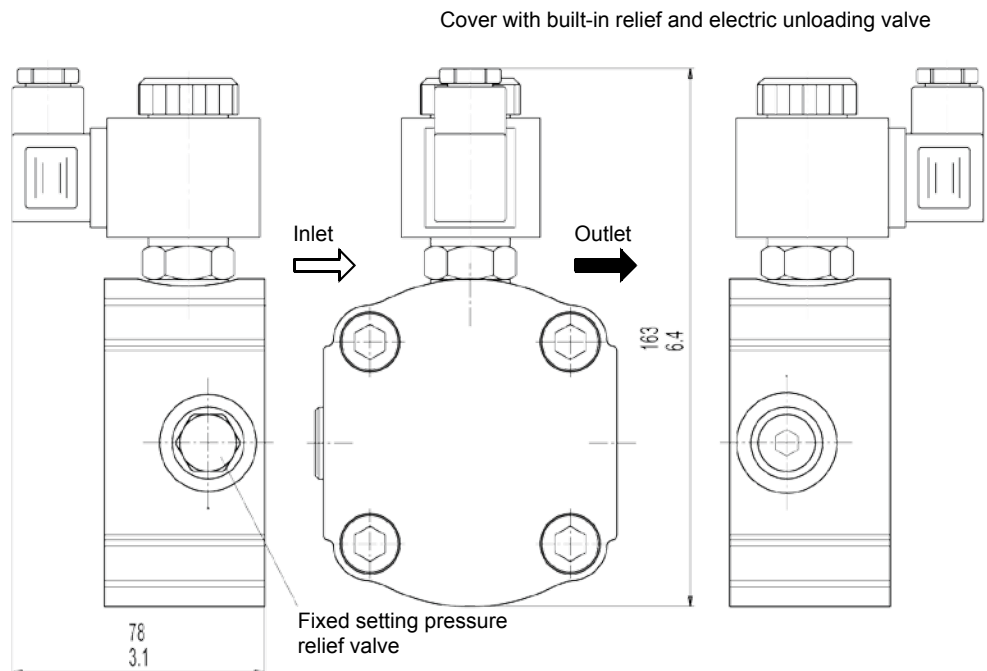
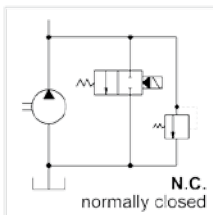

E0.120.0417.02.00IM03



**MULTIPLE GEAR PUMPS
ASSEMBLING DIMENSIONS**

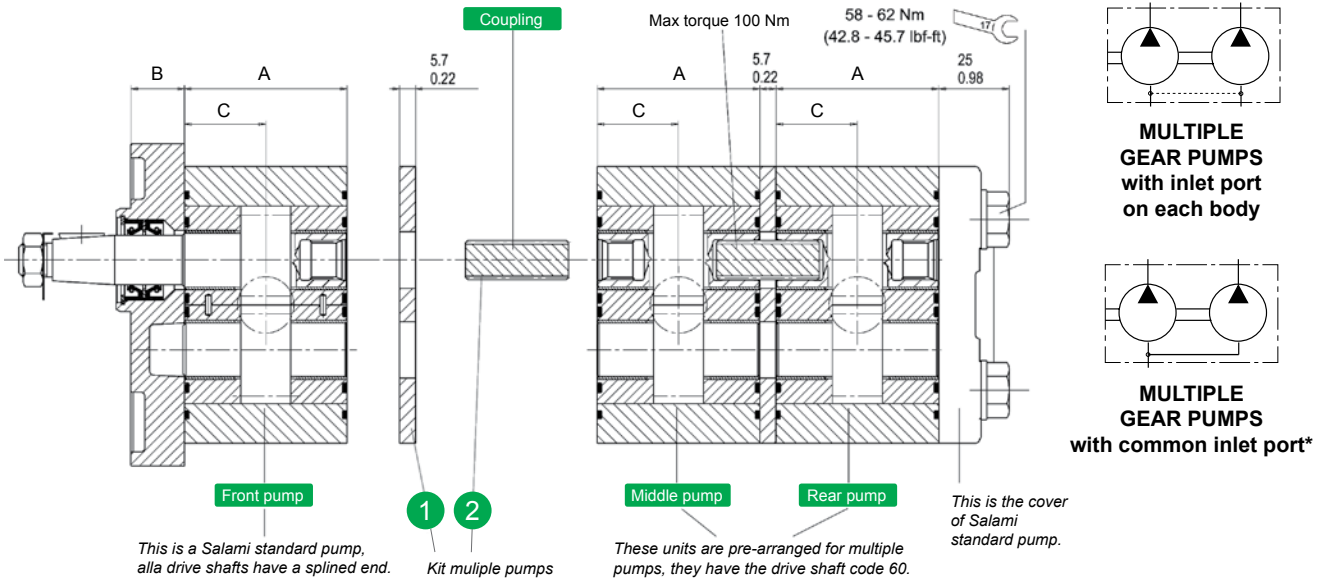

The 2PE pumps can be easily transformed into front pump in the multiple units. All drive shafts are pre-arranged and have a splined end according to DIN 5480. The first unit must always be the same size or bigger than following units. The features and performances are the same of the corresponding single units: only in the case of simultaneous operating you have to verify that the inlet torque is lower than the max. transmissible by the drive shaft. Finally to assembly the multiple pump you need to order bolts of the right length.

*Commercial code UA

Type		3.2*	3.9*	4.5	6.5	8.3	10.5	11.3	12.5	13.8	16	19	22.5	26
Dimension B (flanges B2 - B3)	mm	16.5												
	in	0.65												
Dimension B (flanges P1 - S2 - B1)	mm	19												
	in	0.75												
Dimension C	mm	23.55		25	26.4	28.15	29.75	31.75	33.75	37.8	40.5	43.4		
	in	0.91		0.98	1.04	1.11	1.17	1.25	1.33	1.49	1.59	1.71		
Dimension A	mm	47.1	49.95	52.8	56.3	59.7	63.5	67.5	75.6	81	86.8			
	in	1.83	1.97	2.07	2.22	2.35	2.5	2.65	2.97	3.19	3.42			

*Available only as rear pump

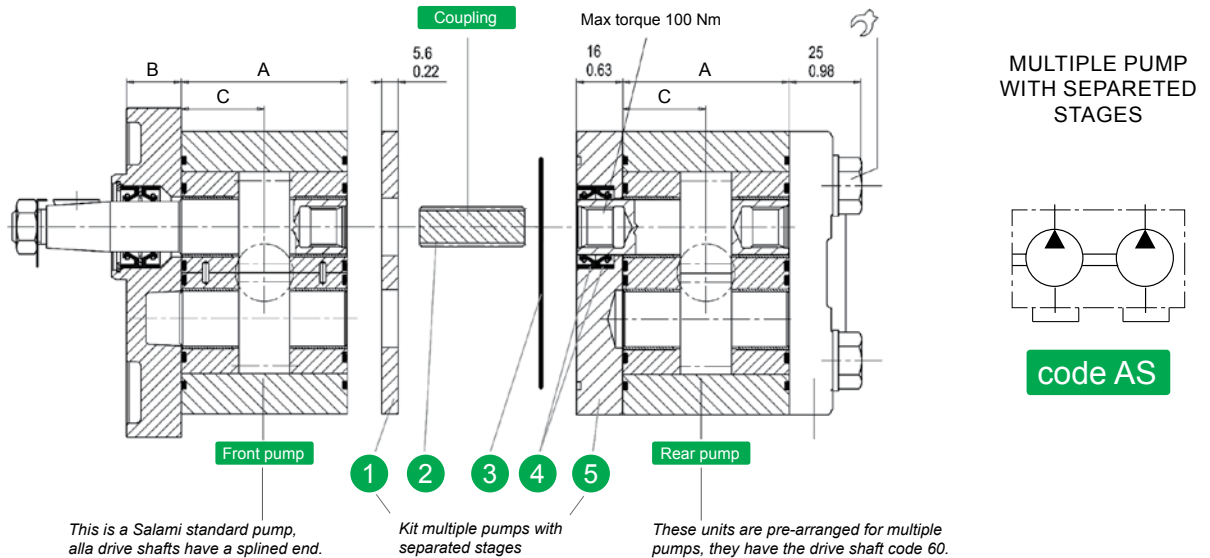

EO.120.0417.02.001M03



2PE COMBINATION WITH PUMP 1.5PE

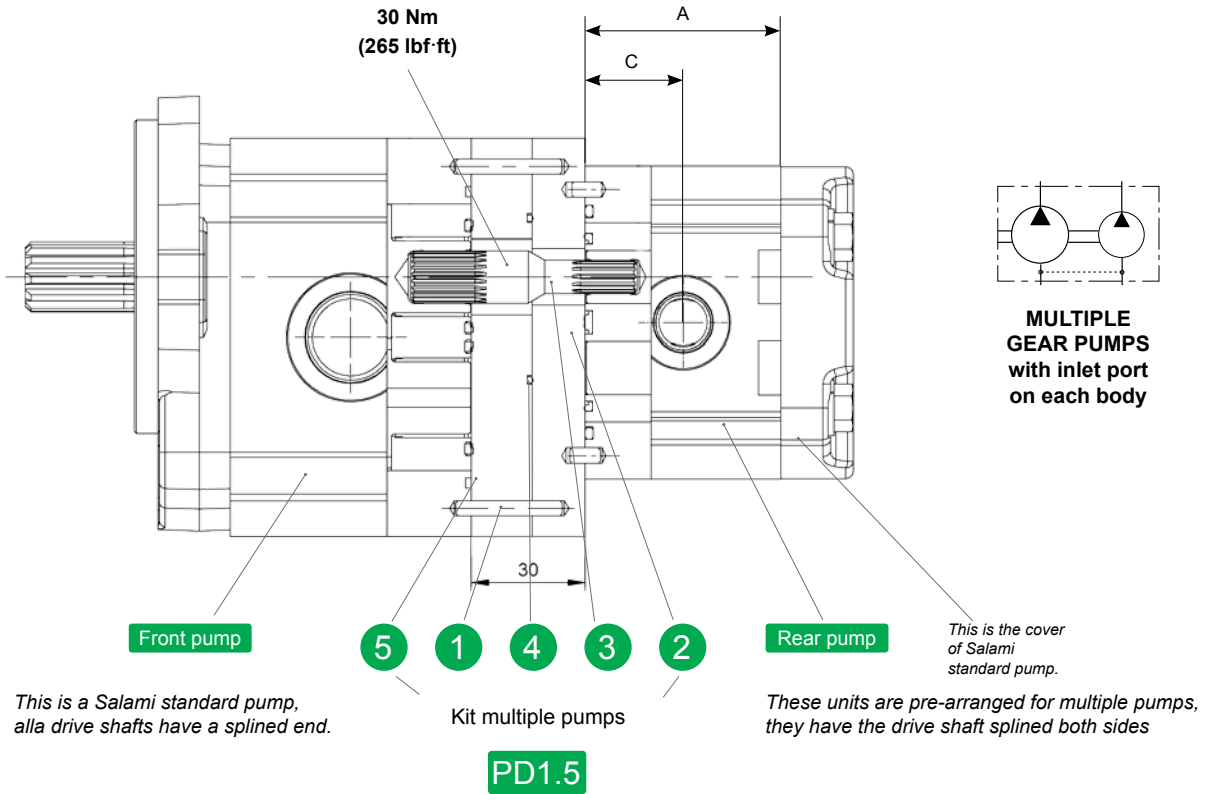

1.5PE-Type		1.4	2.1	2.8	3.5	4.1	5.2	6.2	7.6	9.3	11
Dimension A	mm	44	45.9	47.9	49.9	51.6	54.7	57.5	61.5	66.3	71.1
	in	1.73	1.81	1.89	1.96	2.03	2.15	2.26	2.42	2.61	2.80
Dimension C	mm	22	22.95	23.95	24.95	25.8	27.35	28.75	30.75	33.15	35.55
	in	0.87	0.90	0.94	0.98	1.02	1.08	1.13	1.21	1.31	1.40

E0.120.0417.02.00IM03



PERFORMANCE CURVES

Performance curves carried out with oil viscosity at 21 cSt and oil temperature at 50°C

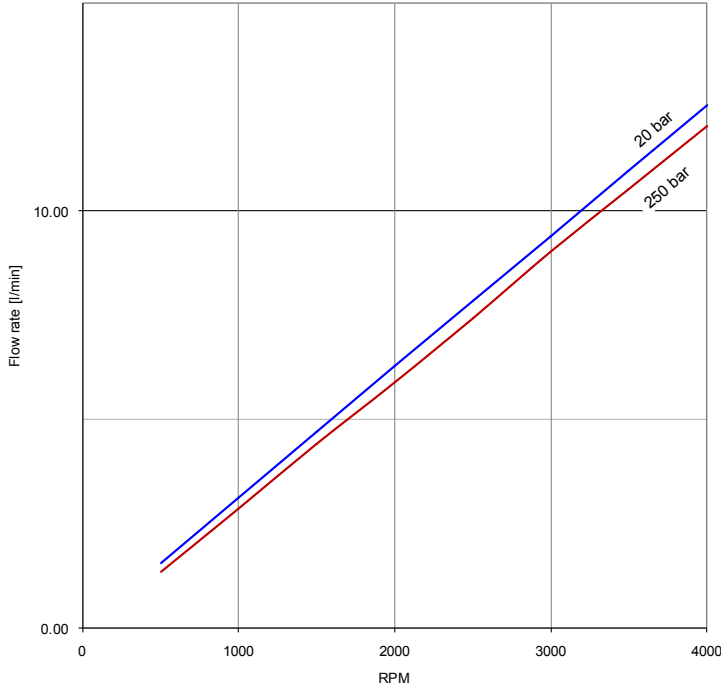

2PE - 3.2

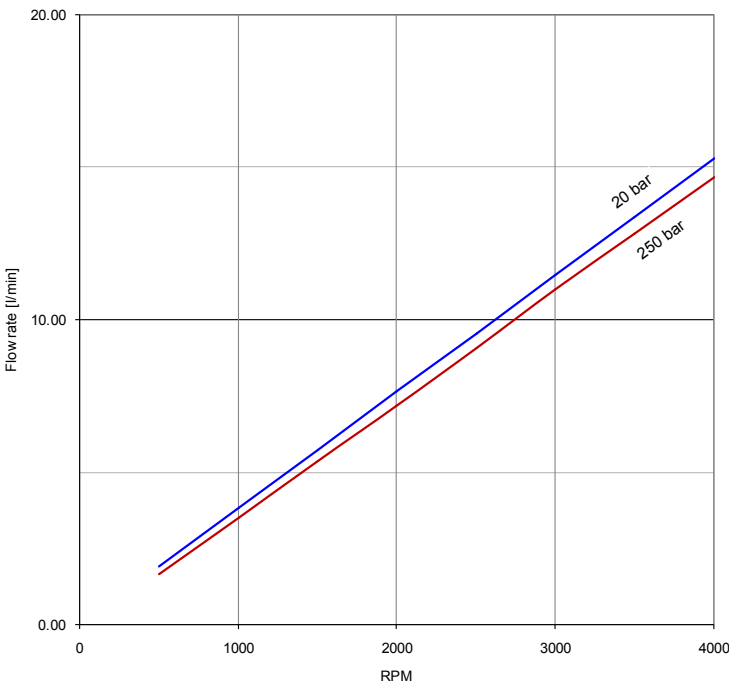
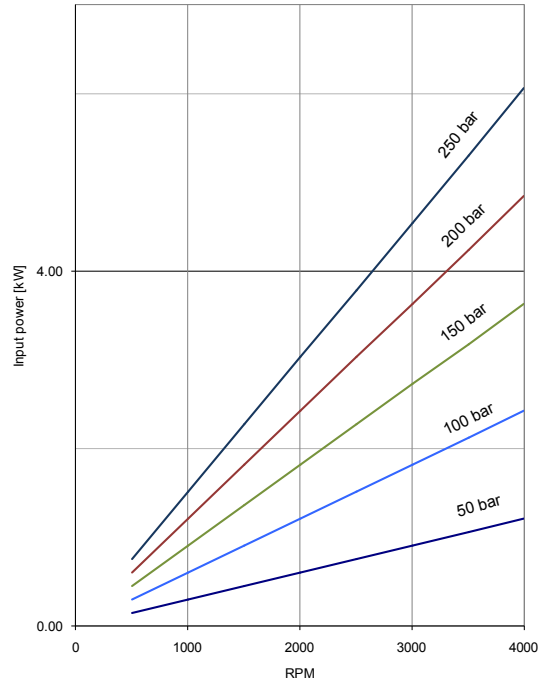

2PE - 3.9

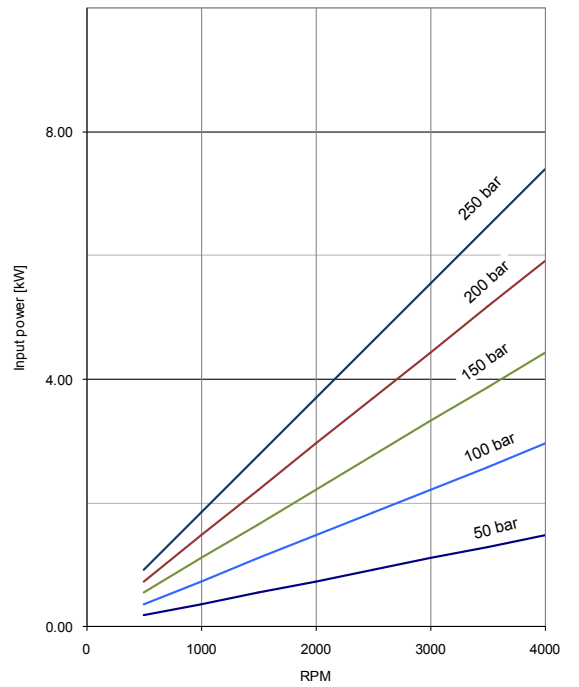

EO.120.0417.02.001M03



PERFORMANCE CURVES

Performance curves carried out with oil viscosity at 21 cSt and oil temperature at 50°C

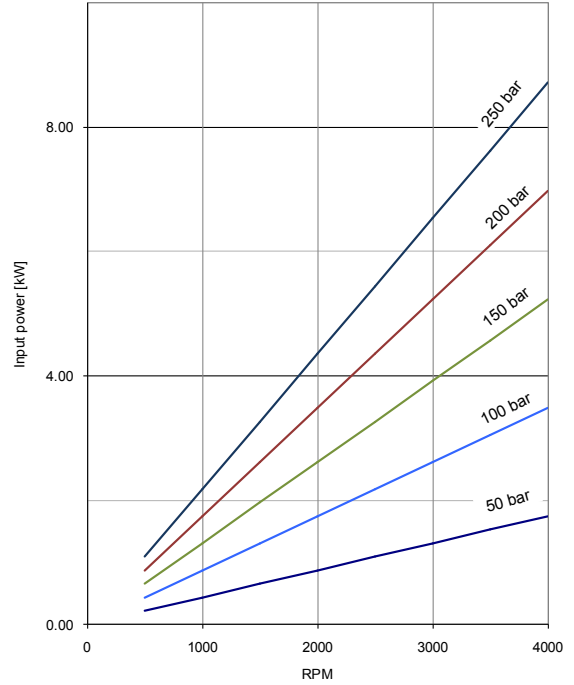
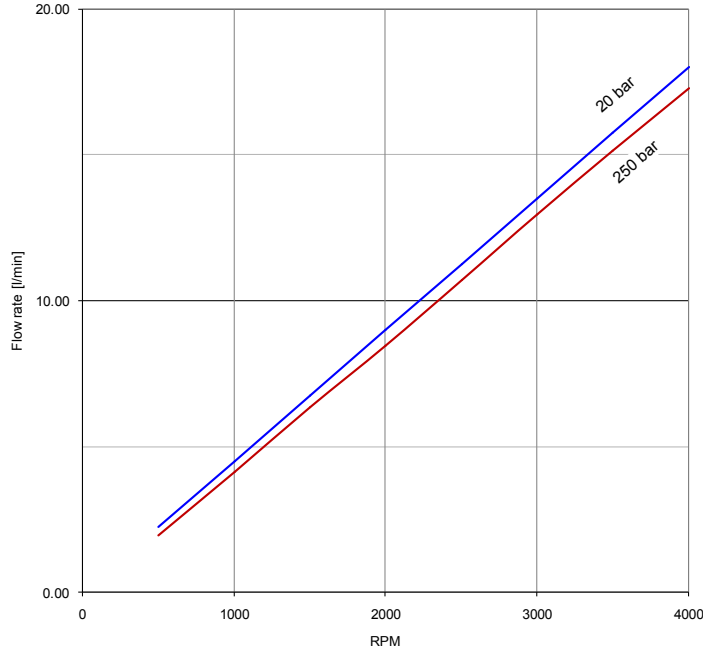

2PE - 4.5

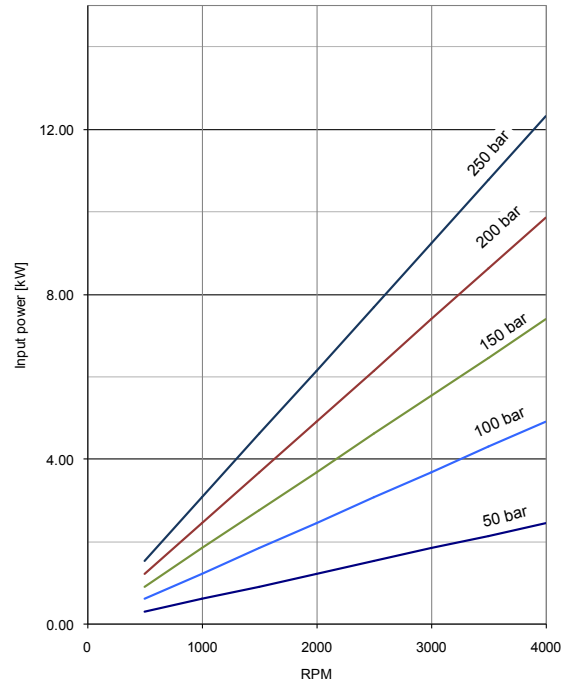
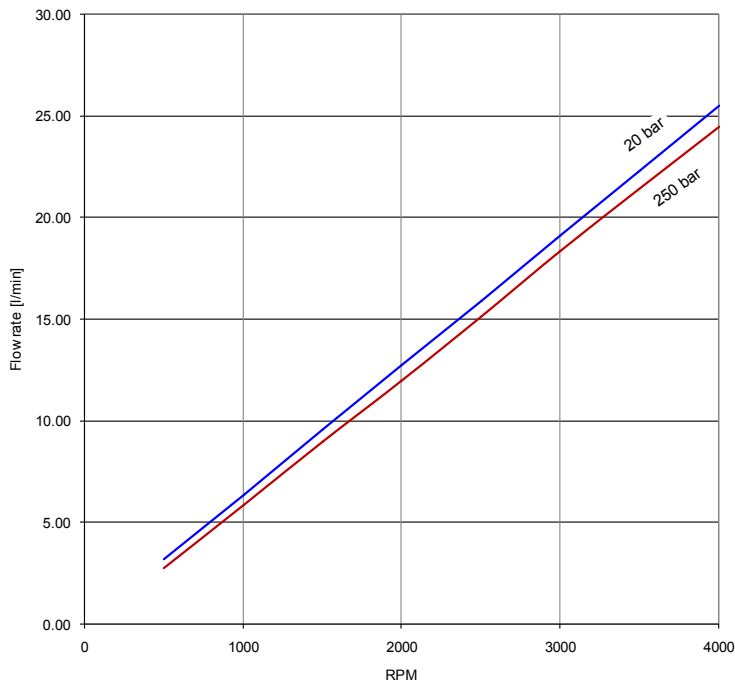

2PE - 6.5

E0.120.0417.02.00IM03



PERFORMANCE CURVES

Performance curves carried out with oil viscosity at 21 cSt and oil temperature at 50°C

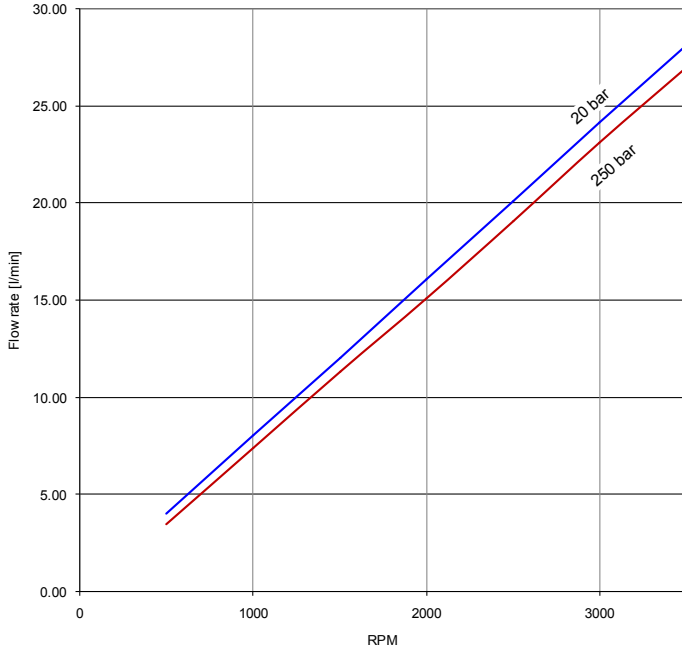

2PE - 8.3

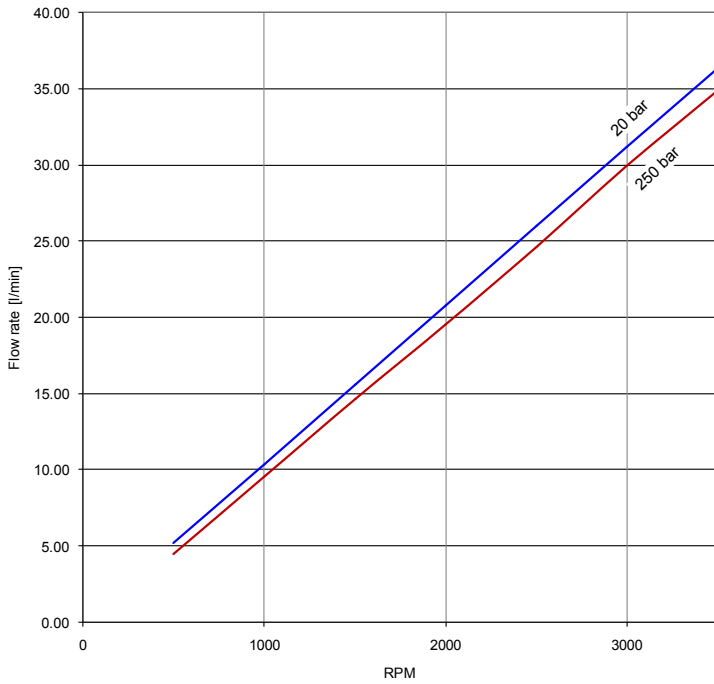
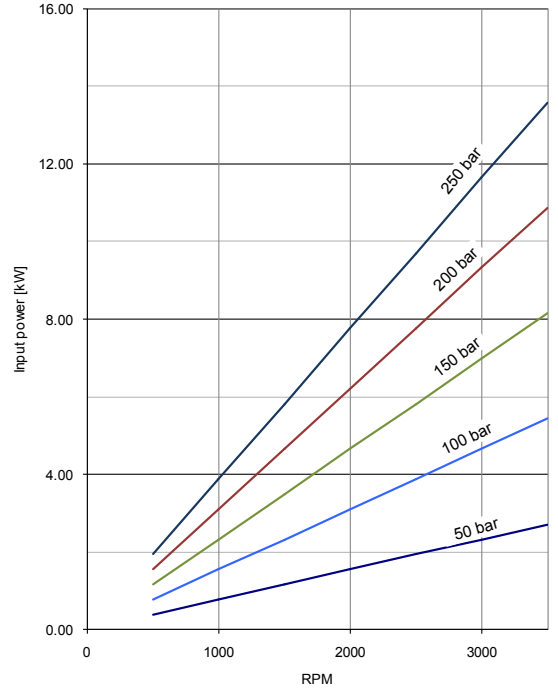

2PE - 10.5

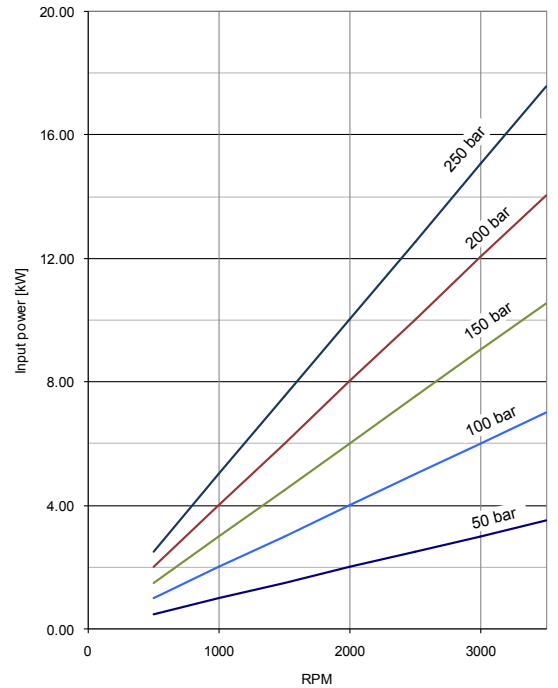

EO.120.0417.02.001M03



PERFORMANCE CURVES

Performance curves carried out with oil viscosity at 21 cSt and oil temperature at 50°C

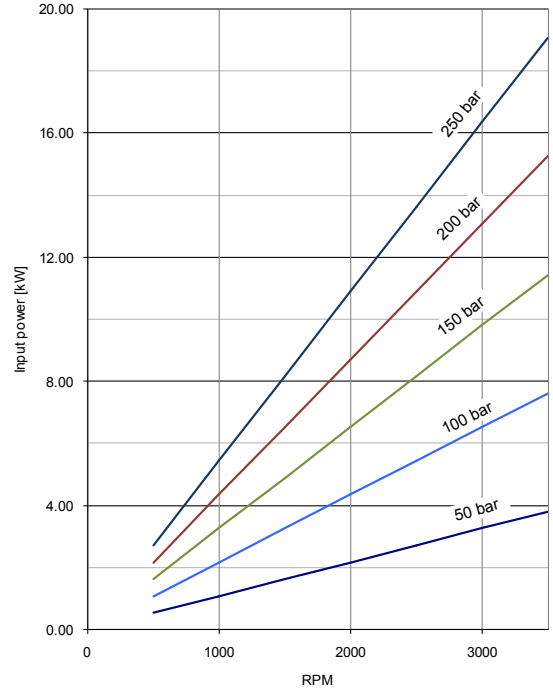
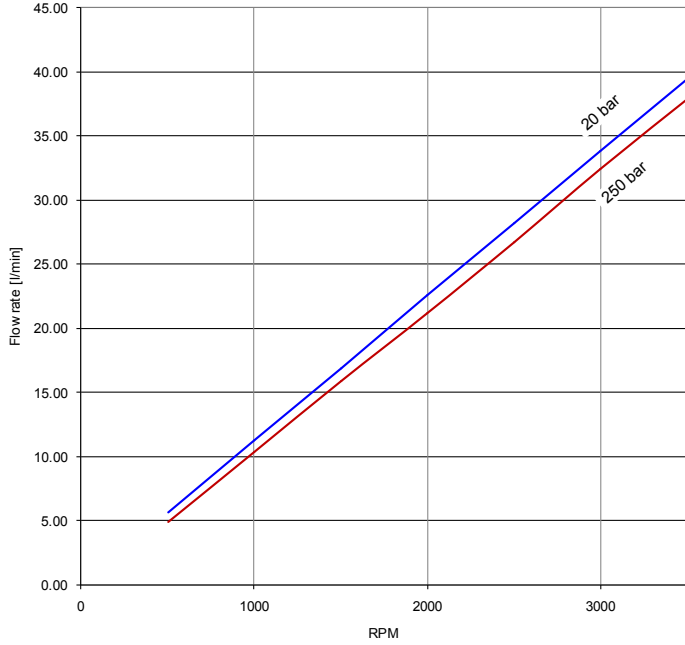

2PE - 11.3

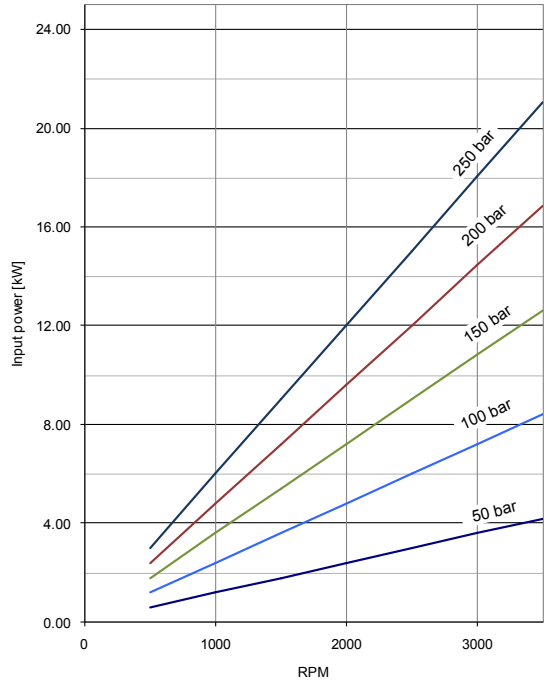
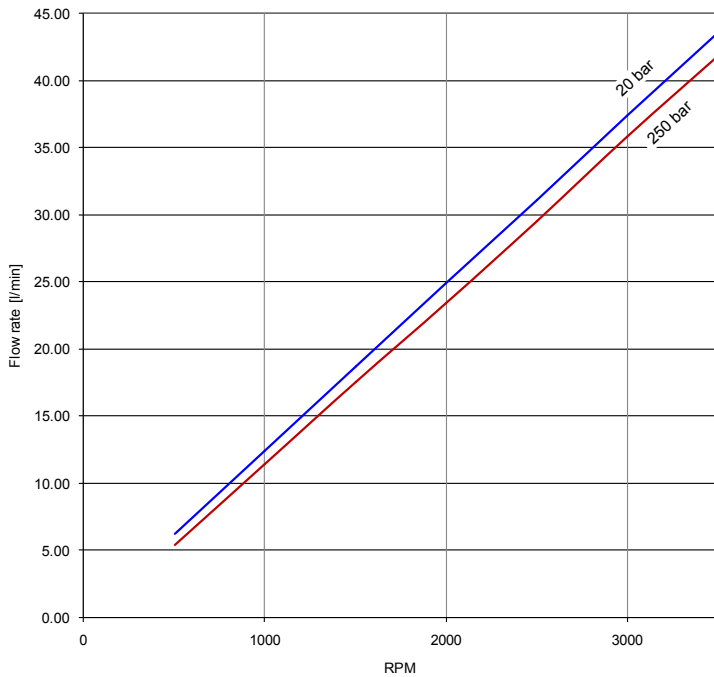

2PE - 12.5

E0.120.0417.02.00IM03



PERFORMANCE CURVES

Performance curves carried out with oil viscosity at 21 cSt and oil temperature at 50°C

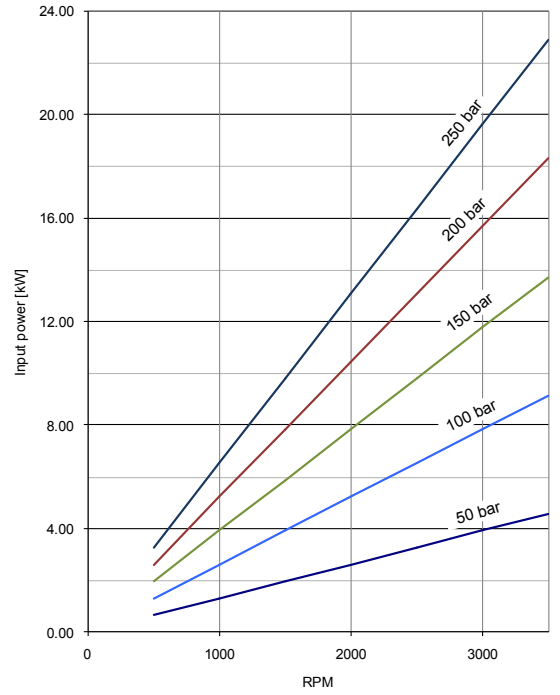
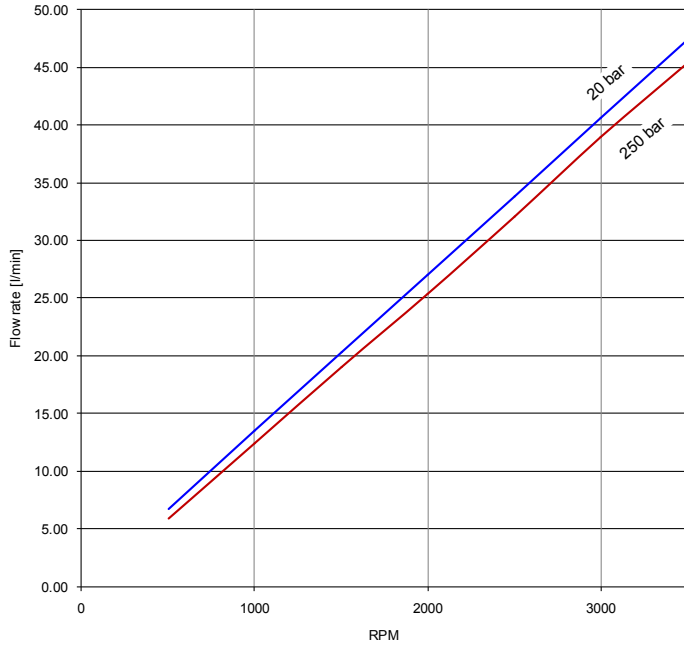

2PE - 13.8

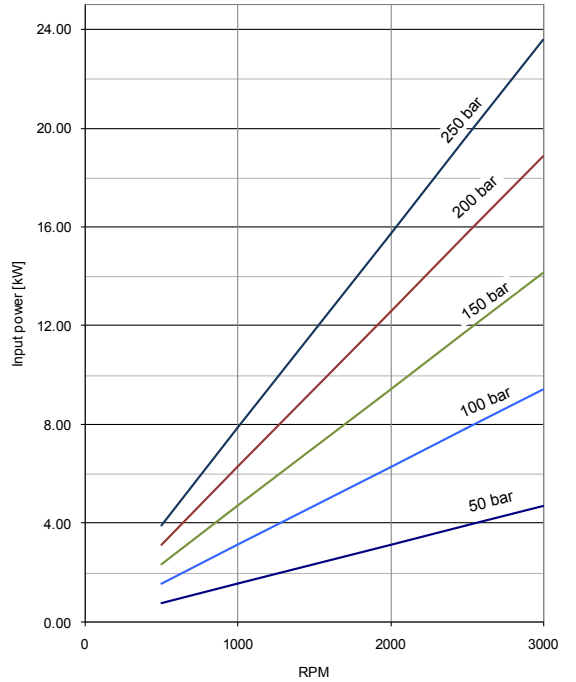
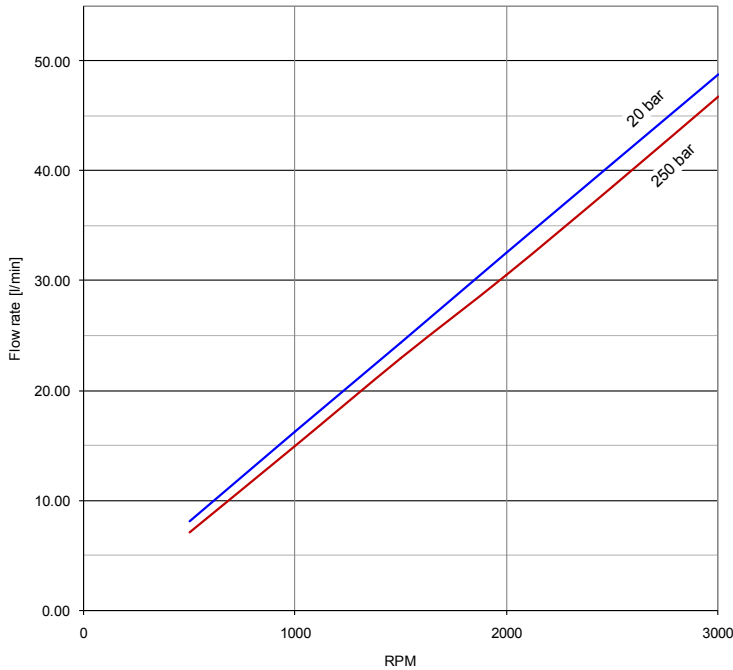

2PE - 16

EO.120.0417.02.001M03



PERFORMANCE CURVES

Performance curves carried out with oil viscosity at 21 cSt and oil temperature at 50°C

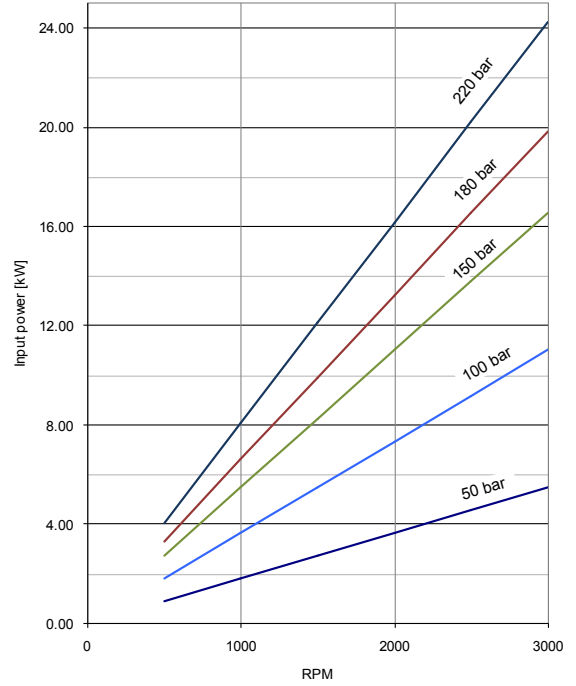
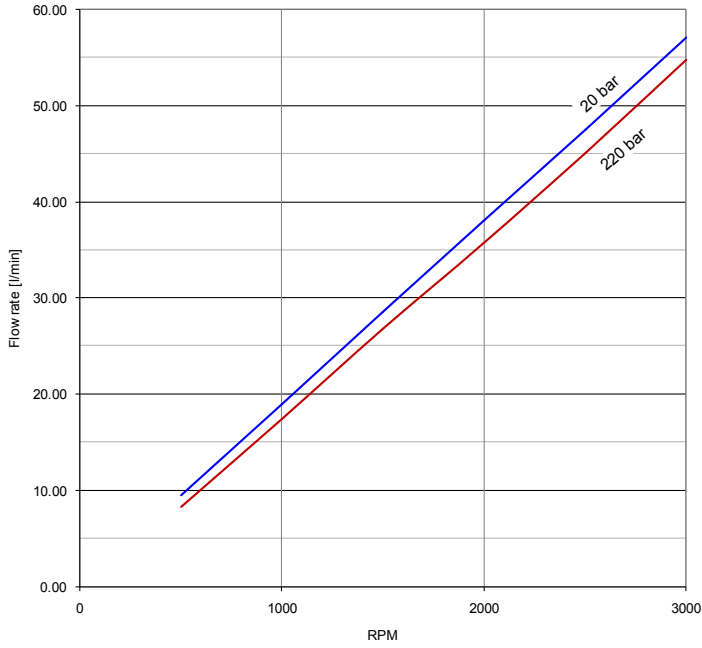

2PE - 19

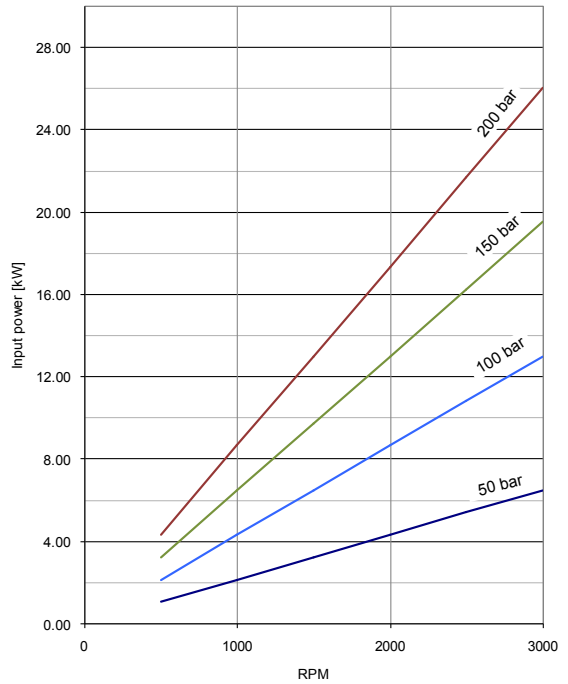
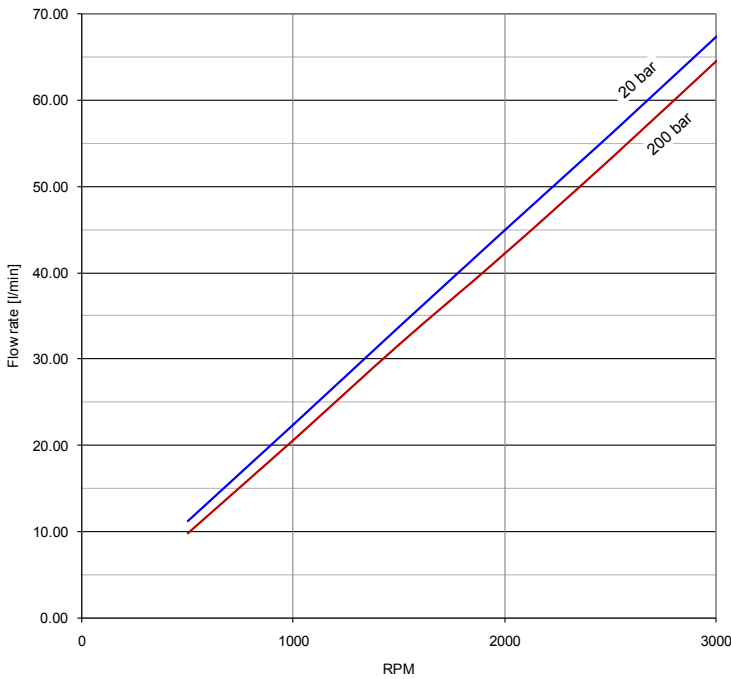

2PE - 22.5

E0.120.0417.02.00IM03



PERFORMANCE CURVES

Performance curves carried out with oil viscosity at 21 cSt and oil temperature at 50°C

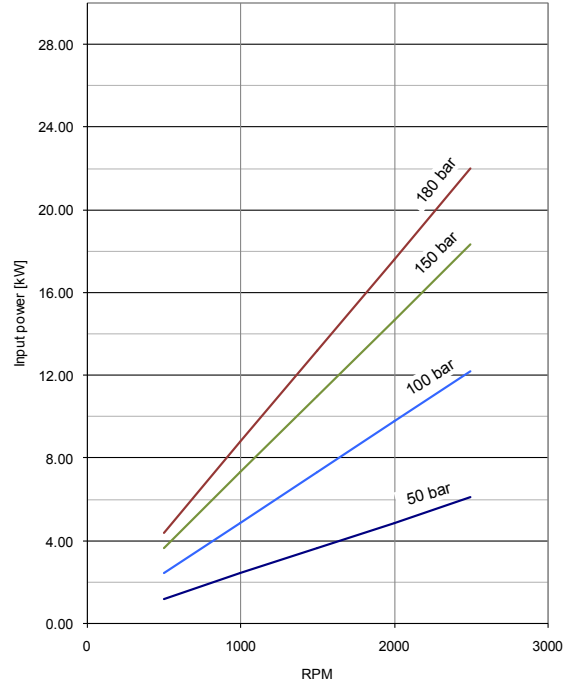
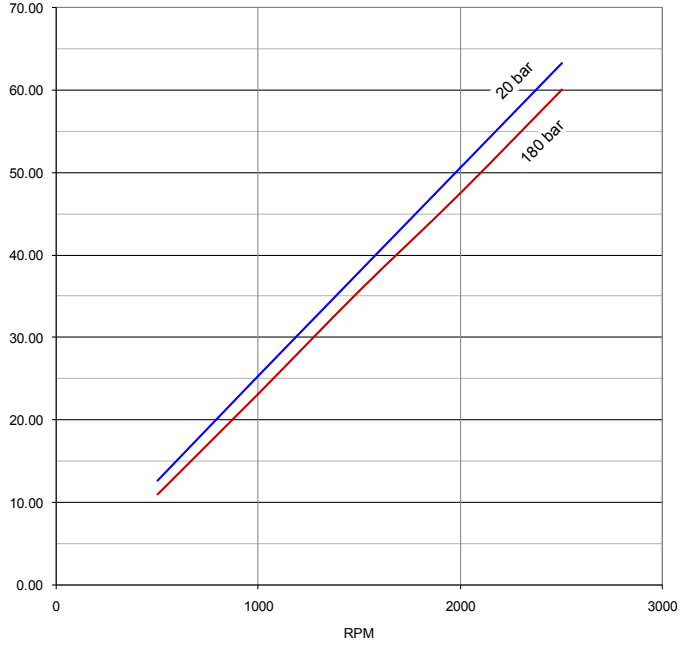

2PE - 26

EO.120.0417.02.001M03



SINGLE PUMPS

Adjustable flow l/min

Setting main relief valve (bar)

2PE A B C D E F G H I L

16 D P 28 P1 V 1 CP PD1.5 VS

TYPE	A	DISPLACEMENTS	
4.5	4.6 cm ³ /rev.	0.27 cu.in/rev.	
6.5	6.5 cm ³ /rev.	0.40 cu.in/rev.	
8.3	8.2 cm ³ /rev.	0.50 cu.in/rev.	
10.5	10.6 cm ³ /rev.	0.65 cu.in/rev.	
11.3	11.5 cm ³ /rev.	0.68 cu.in/rev.	
12.5	12.5 cm ³ /rev.	0.77 cu.in/rev.	
13.8	13.8 cm ³ /rev.	0.84 cu.in/rev.	
16	16.6 cm ³ /rev.	1.01 cu.in/rev.	
19	19.4 cm ³ /rev.	1.18 cu.in/rev.	
22.5	22.9 cm ³ /rev.	1.37 cu.in/rev.	
26	25.8 cm ³ /rev.	1.58 cu.in/rev.	

ROTATION (page 6)	CODES	B
Clockwise	D	
Anti-clockwise	S	
Reversible	R	

PORTS (page 35)	CODES	C
Flanged ports european standard	P	
Flanged ports german standard	B	
Threaded ports GAS (BSPP)	G	
Threaded ports SAE (ODT)	R	

DRIVE SHAFT (page 36)	CODES	D
Tang drive for electric motors	03	
Tang drive	04	
Tapered 1:5	25	
Tapered 1:5 (only for CB)	26	
Tapered 1:8	28	
SAE A splined 9T	52	
SAE A splined 10T	53	
SAE A splined 11T	54	
SAE B splined 13T	55	
DIN 5480 internal splined (only for rear pumps- see page 51)	60	
9 teeth DIN 5482 splined	62	
5/8" SAE A parallel	82	
3/4" SAE A parallel	85	

L VALVES IN THE COVER (page 46)	CODES
Adjustable main relief valve	VS
Fixed setting main relief valve	VSE
Internal drain	IDV
Priority flow divider with excess flow to 2nd actuator	VP-VP1
Like VP with main relief valve	VPS-VPS1
Priority flow divider with Load sensing with dynamic signal	VPD-VPD1
Load sensing priority valve with dynamic signal with main relief valve	VPDS-VPDS1
Electric unloading valve (12V)	EV1/EV3
Electric unloading valve (24V)	EV2/EV4
Main relief and electric unloading valves (12V)	EVS1/EVS3
Main relief and electric unloading valves (24V)	EVS2/EVS4

I REAR COVER (page 52)	CODE
Pre-arranged for 1.5PE rear	PD1.5

H OUTRIGGER BEARING (page 41)	CODES
European standard	CP
German standard	CB
For engine endothermic motors	CL
For endothermic motors with axial and radial loads	CF
SAE A	CS

G PORTS POSITION	CODE
Lateral ports standard	
Rear ports (page)	1

F SEAL	CODE
Buna standard	
Viton	V

E MOUNTING FLANGES (page 38)	CODES
European standard	P1
German standard Ø80	B1
German standard Ø52	B2-B3
German standard Ø50	B4-B5
SAE A 2 bolts	S2
SAE B 2 bolts	S3
SAE A 2 bolts (with o-ring on the centering collar)	S6
4 bolts for Iveco motor	C1
4 bolts for Perkins motor	K1
German standard with shaft seal Ø52	K3
German standard with shaft seal Ø52	K4
2 threaded holes flange for Perkins motor	MF

Order example 2PE 19D, ports SAE (R), drive shaft (52), mounting flange (S2) with valve in the cover (VPS 12.5 l/min) and pressure relief valve setting 180 bar:
2PE19D-R52S2-VPS12.5/180

E0.120.0417.02.00IM03



MULTIPLE PUMPS

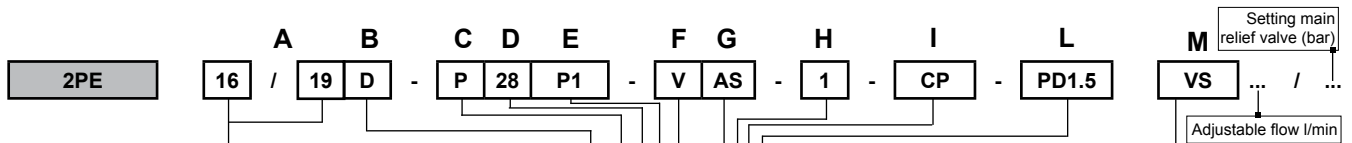

TYPE	A	DISPLACEMENTS	
3.2*		3.2 cm ³ /rev.	0.19 cu.in/rev.
3.9*		3.9 cm ³ /rev.	0.24 cu.in/rev.
4.5		4.6 cm ³ /rev.	0.27 cu.in/rev.
6.5		6.5 cm ³ /rev.	0.40 cu.in/rev.
8.3		8.2 cm ³ /rev.	0.50 cu.in/rev.
10.5		10.6 cm ³ /rev.	0.65 cu.in/rev.
11.3		11.5 cm ³ /rev.	0.68 cu.in/rev.
12.5		12.5 cm ³ /rev.	0.77 cu.in/rev.
13.8		13.8 cm ³ /rev.	0.84 cu.in/rev.
16		16.6 cm ³ /rev.	1.01 cu.in/rev.
19		19.4 cm ³ /rev.	1.18 cu.in/rev.
22.5		22.9 cm ³ /rev.	1.37 cu.in/rev.
26		25.8 cm ³ /rev.	1.58 cu.in/rev.

*Available only as rear pump

ROTATION (page 6)	CODES	B
Clockwise	D	
Anti-clockwise	S	

PORTS (page 35)	CODES	C
Flanged ports european standard	P	
Flanged ports german standard	B	
Threaded ports GAS (BSPP)	G	
Threaded ports SAE (ODT)	R	

DRIVE SHAFT (page 36)	CODES	D
Tang drive for electric motors	03	
Tang drive	04	
Tapered 1:5	25	
Tapered 1:5 (only for CB)	26	
Tapered 1:8	28	
SAE A splined 9T	52	
SAE A splined 10T	53	
SAE A splined 11T	54	
SAE B splined 13T	55	
DIN 5482 splined 9T	62	
5/8" SAE A parallel	82	
3/4" SAE A parallel	85	

*UA: this type of multiple pump is a Salami standard multiple pump which has only one inlet port opened, all the other inlet port are closed.

In case of common suction, the code 1 - 2 or 3, correspond to the body where inlet is located.

M	VALVES IN THE COVER (page 46)	CODES
	Adjustable main relief valve	VS
	Fixed setting main relief valve	VSE
	Internal drain	IDV
	Unloading valve	VSQ
	Priority flow divider with excess flow to 2nd actuator	VP-VP1
	Like VP with main relief valve	VPS-VPS1
	Priority flow divider with Load sensing with dynamic signal	VPD-VPD1
	Load sensing priority valve with dynamic signal with main relief valve	VPDS-VPDS1
	Electric unloading valve (12V)	EV1/EV3
	Electric unloading valve (24V)	EV2/EV4
	Main relief and electric unloading valves (12V)	EVS1/EVS3
	Main relief and electric unloading valves (24V)	EVS2/EVS4

L	REAR COVER (page 52)	CODE
	Pre-arranged for 1.5PE rear	PD1.5

I	OUTRIGGER BEARING (page 41)	CODES
	European standard	CP
	German standard	CB
	For engine endothermic motors	CL
	For endothermic motors with axial and radial loads	CF
	SAE A	CS

H	PORTS POSITION	CODE
	Lateral ports standard	
	Rear ports (page)	1

G	SUCTION PORTS	CODES
	Common suction	UA*
	Separated stages	AS

F	SEAL	CODE
	Buna standard	
	Viton	V

E	MOUNTING FLANGES (page 38)	CODES	MOUNTING FLANGES	CODES
	European standard	P1	SAE A 2 bolts (with o-ring on the centering collar)	S6
	German standard Ø80	B1	4 bolts for Iveco engines	C1
	German standard Ø52	B2-B3	4 bolts for Perkins motor	K1
	German standard Ø50	B4-B5	German standard with shaft seal Ø52	K3
	SAE A 2 bolts	S2	German standard with shaft seal Ø52	K4
	SAE B 2 bolts	S3	2 threaded holes flange for Perkins motor	MF

EO.120.0417.02.001M03



You can find our most up to date “STANDARD SALES CONDITIONS” on our website.

Potete trovare le nostre più aggiornate “CONDIZIONI DI VENDITA STANDARD”
sul nostro sito.

www.salami.it

T. +39 059 387 411

sales@salami.it

Watch our tutorials on youtube channel



Salami Fluid Power
Salami Fluid Power World
Salami Fluid Power France
Salami Fluid Power España
Salami Fluid Power Deutsch

SALAMI S.P.A.

Via Emilia Ovest 1006
41121 Modena (Italy)
T. +39 059 387 411
F. +39 059 387 639
sales@salami.it

SALAMI ESPAÑA

Poligono Industrial Armenteres
C/Primer de Maig, 18, Nave 4
08980 San Feliu de Llobregat
Barcelona
T. +34-93-6665451
F. +34-93-6667826
info@salamispain.com

SALAMI FRANCE

22, rue Louis Saillant
69120 Valux en Velin
Lyon
T. +33-04-78809941
F. +33-04-78803669
e.pasian@salami.fr

SALAMI HYDRAULICS N.A INC

4630 Crossroads Park Drive
Liverpool
NY 13088 - USA
T. +1-315-295-2363
F. +1-315-295-2364
info@salamihydraulics.com