1.5PE

Aluminium gear pumps

Technical Catalogue

E0.109.0417.02.00IM02



GEAR PUMPS

SALAMI gear pumps are available with displacements from 1.4 cm³/rev to 99 cm³/rev (*from 0.09 cu.in/rev to 6.03 cu.in/rev*).

Multiple pumps can always be relized combining stages taken from different or same series.

Several options of shafts, flanges and ports as for European, German and American standards are available for all the pumps.

SALAMI gear pumps offer:

- High volumetric efficiency thanks to an innovative design and an accurate control of machining tolerances.
- Axial compensation achieved by the use of floating bushes that allow high volumetric efficiency throughout the working pressure range.
- DU bearings to ensure high pressure capability.
- 12 teeth integral gear and shaft.
- Aluminium body.
- Cast iron flange and cover.
- Double shaft seals.
- Nitrile seals as standard and Viton seals in high temperature applications.
- All pumps are hydraulically tested after assembly to ensure the highest standard performance.
- Gear pumps are ideal for mobile equipment including: snow plows, light duty equipment, farm vehicles, town trucks, cherry pickers, lift gates, utility vehicles, aerial devices, hoists, spreaders, fan drive.
- Also available Bidirectional rotation.

TECHNICAL DATA

- Pump inlet pressure (absolute pressure)	0.8 to 1.5 bar (11.6 to 21.7 psi)
- Minimum operating fluid viscosity	12 mm ² / sec
- Max starting viscosity	800 mm ² / sec
- Suggested fluid viscosity range	17 - 65 mm ² / sec
- Fluid operating temperature range	-20 to 80 °C
- Fluid operating temperature range with FPM seals (Viton)	-15 to 110°C
- Fluid operating temperature range with HNBR seals*	-30 to 110°C
- Hydraulic fluid	mineral oil

*Available on request.

DEFINITION OF PRESSURES

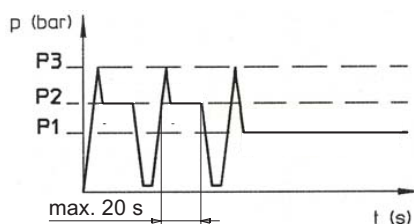

P3 = Peak pressure

P2 = Intermittent operating pressure (1/3 of working time)

P1 = Continuous operating pressure



DRIVE SHAFTS

Radial and axial loads on the shafts must be avoided since they reduce the life of the unit. In order to avoid misalignment during the assembly with the primary engine, a connection with “Oldham” coupling (or coupling having convex toothed hub) is recommended.

ROTATION

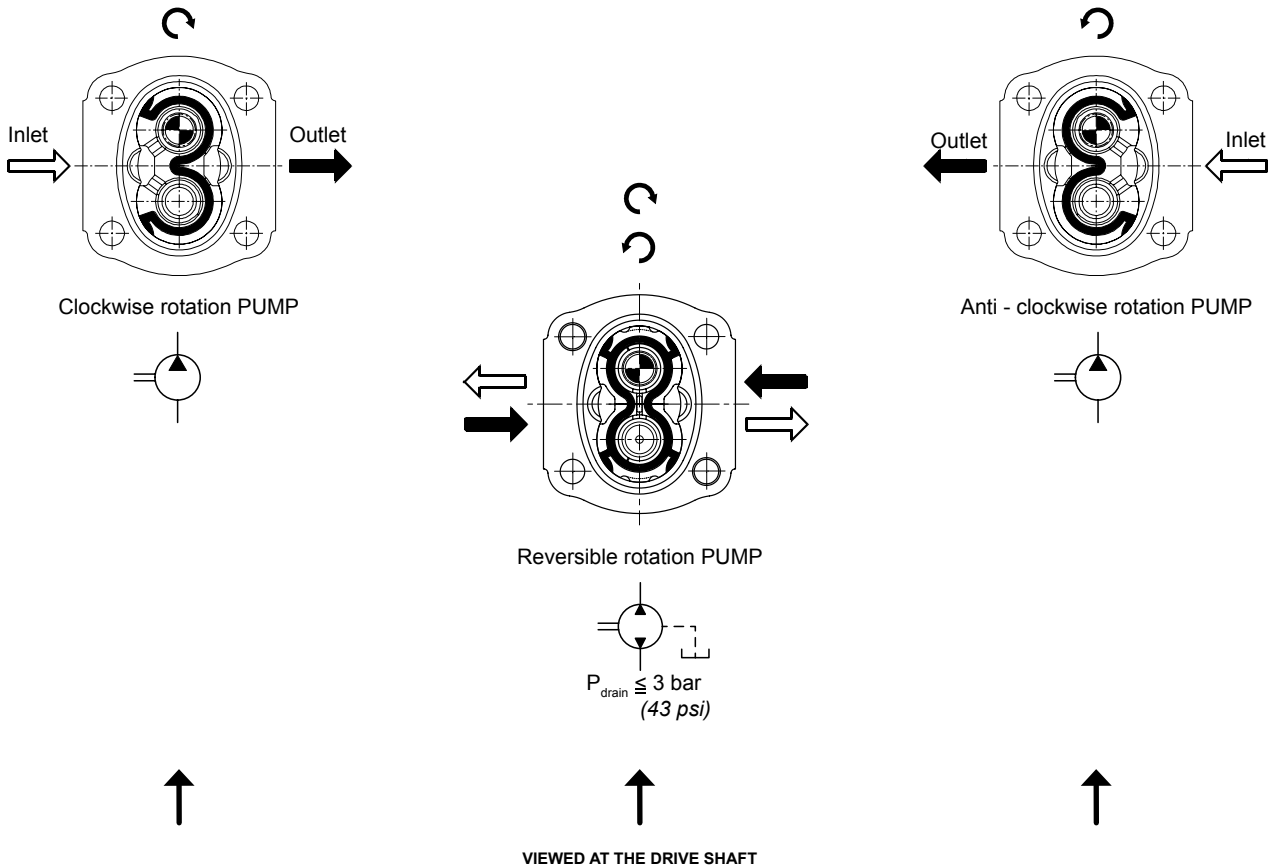

HYDRAULIC PIPE LINE

To ensure favorable suction conditions it is important to keep pressure drop in suction pipe line to a minimum value (see TECHNICAL DATA). To calculate hydraulic pipe line size, the designer can use; as an approximate guide, the following fluid speed figures:

From 1 to 2 m/sec on suction pipe line
From 6 to 10 m/sec on pressure pipe line

From 3.28 to 6.36 ft/sec on suction pipe line
From 19.7 to 32.8 ft/sec on pressure pipe line

The lowest fluid speed values in pipe lines is recommended when the operating temperature range is high and/or for continuous duty.

The highest value is recommended when the temperature difference is low and/or for intermittent duty.

When tandem pumps are supplied by 2 different reservoirs with 2 different fluids it is necessary to specify “AS” version.

FILTRATION INDEX RECOMMENDED

Working pressure	>200 bar/2900 psi	<200 bar/2900 psi
Contamination class NAS 1638	9	10
Contamination class ISO 4406	19/18/15	20/19/16
Achieved with filter $\beta_x=75$	15 μm	25 μm

FIRE RESISTENT FLUID

Type	Description	Max pressure	Max speed (rpm)	Temperature
HFB	Oil emulsion with 40% water	130 bar/1880 psi	2500	3°C+65°C
HFC	Water glycol	180 bar/2600 psi	1500	-20°C+65°C
HFD	Phosphate esters		1750	-10°C+80°C

COMMON FORMULAS FOR PUMPS

$$C = \text{Input torque} = \frac{q \cdot \Delta p}{62.8 \cdot \eta_m} \text{ (Nm)}$$

$$P = \text{Input power} = \frac{q \cdot n \cdot \Delta p \cdot 10^{-3}}{600 \eta_m} \text{ (kW)}$$

$$Q = \text{Outlet flow} = \frac{q \cdot n \cdot \eta_v}{1000} \text{ (l/min)}$$

LEGENDA

Δp = Working pressure (bar)

q = Displacement (cm^3/rev)

n = Speed (min^{-1})

η_m = Mechanical eff. (0.92)

η_v = Volumetric eff. (0.95)

IDENTIFICATION LABEL

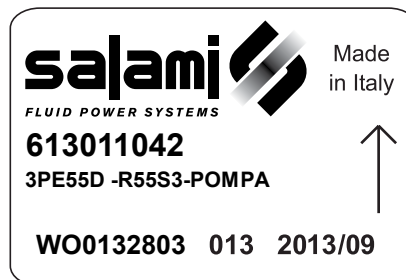

Salami part number
Product short description

Rotation sense

Product code (for Salami management)

Month and year of made
Number of assembling

EO.100.0417.02.001M01

WORKING CONDITIONS

	Displacement		Continuous pressure P ^{1**}		Intermittent pressure P ²		Peak pressure P ³		Max. speed	Min. speed
	cm ³ /rev	cu.in/rev	bar	psi	bar	psi	bar	psi		
GROUP 1.5 - E SERIES									min ⁻¹	
1.5PE - 1.4	1.4	0.09	250	3625	270	3915	290	4205	5000	700
1.5PE - 2.1	2.1	0.13	250	3625	270	3915	290	4205	5000	700
1.5PE - 2.8	2.8	0.17	250	3625	270	3915	290	4205	4500	700
1.5PE - 3.5	3.5	0.21	250	3625	270	3915	290	4205	4500	700
1.5PE - 4.1	4.1	0.25	250	3625	270	3915	290	4205	4000	700
1.5PE - 5.2	5.2	0.32	230	3335	250	3625	270	3915	4000	700
1.5PE - 6.2	6.2	0.38	230	3335	250	3625	270	3915	3600	600
1.5PE - 7.6	7.6	0.46	200	2900	220	3190	250	3625	3300	600
1.5PE - 9.3	9.3	0.57	180	2610	200	2900	240	3480	3000	600
1.5PE - 11	11	0.67	170	2465	190	2755	220	3190	3000	600

	Displacement		Continuous pressure P ^{1**}		Intermittent pressure P ²		Peak pressure P ³		Max. speed	Min. speed
	cm ³ /rev	cu.in/rev	bar	psi	bar	psi	bar	psi		
GROUP 2 - E SERIES									min ⁻¹	
2PE - 3.2*	3.2	0.19	250	3625	280	4060	300	4350	4000	600
2PE - 3.9*	3.9	0.24	250	3625	280	4060	300	4350	4000	600
2PE - 4.5	4.6	0.27	250	3625	280	4060	300	4350	4000	600
2PE - 6.5	6.5	0.4	250	3625	280	4060	300	4350	4000	600
2PE - 8.3	8.2	0.5	250	3625	280	4060	300	4350	3500	500
2PE - 10.5	10.6	0.65	250	3625	280	4060	300	4350	3500	500
2PE - 11.3	11.5	0.68	250	3625	280	4060	300	4350	3500	500
2PE - 12.5	12.7	0.77	250	3625	280	4060	300	4350	3500	500
2PE - 13.8	13.8	0.84	250	3625	280	4060	300	4350	3500	500
2PE - 16	16.6	1.01	250	3625	280	4060	300	4350	3000	400
2PE - 19	19.4	1.15	220	3190	240	3480	260	3750	3000	400
2PE - 22.5	22.9	1.37	200	2900	220	3190	240	3480	2750	400
2PE - 26	25.8	1.58	180	2610	200	2900	220	3190	2500	400

*Available only as rear pump

	Displacement		Continuous pressure P ^{1**}		Intermittent pressure P ²		Peak pressure P ³		Max. speed	Min. speed
	cm ³ /rev	cu.in/rev	bar	psi	bar	psi	bar	psi		
GROUP 2.5 - B SERIES									min ⁻¹	
2.5PB - 5.5*	5.97	0.36	250	3625	280	4060	300	4350	3000	600
2.5PB - 8.3*	8.29	0.50	250	3625	280	4060	300	4350	3000	600
2.5PB - 11.5*	11.76	0.72	250	3625	280	4060	300	4350	3000	600
2.5PB - 13.8*	14.07	0.86	250	3625	280	4060	300	4350	3000	600
2.5PB - 16	16	0.97	250	3625	280	4060	300	4350	3000	600
2.5PB - 19	19.3	1.17	250	3625	280	4060	300	4350	3000	600
2.5PB - 22	22.2	1.35	250	3625	280	4060	300	4350	3000	500
2.5PB - 25	25.2	1.53	250	3625	280	4060	300	4350	3000	500
2.5PB - 28	27.6	1.68	250	3625	280	4060	300	4350	3000	500
2.5PB - 32	32.4	1.97	230	3335	250	3625	260	3750	3000	500
2.5PB - 38	38.1	2.32	200	2900	220	3190	240	3480	2750	400
2.5PB - 44	44.2	2.69	170	2465	190	2755	210	3040	2500	400

*Available only as rear pump. Displacements 11.5-13.8 are available as single pump only with drive shaft “55”.



	Displacement		Continuous pressure P ^{1**}		Intermittent pressure P ²		Peak pressure P ³		Max. speed	Min. speed
	cm ³ /rev	cu.in/rev	bar	psi	bar	psi	bar	psi		
GROUP 3 - E SERIES									min ⁻¹	
3PE - 21*	20.6	1.26	250	3625	280	4060	300	4350	3000	600
3PE - 27	27	1.65	250	3625	280	4060	300	4350	3000	600
3PE - 33	33.5	2.04	250	3625	280	4060	300	4350	3000	600
3PE - 38	38.7	2.36	250	3625	280	4060	300	4350	2750	500
3PE - 46	46.9	2.86	250	3625	270	3915	280	4060	2750	500
3PE - 55	54.1	3.3	220	3190	240	3480	250	3625	2500	400
3PE - 65	63.1	3.85	200	2900	220	3190	240	3480	2500	400
3PE - 75*	73.4	4.48	180	2610	200	2900	220	3190	2500	400

*Displacements 21 and 75 are special release, please contact sales department.

	Displacement		Continuous pressure P ^{1**}		Intermittent pressure P ²		Peak pressure P ³		Max. speed	Min. speed
	cm ³ /rev	cu.in/rev	bar	psi	bar	psi	bar	psi		
GROUP 3.5 - C SERIES									min ⁻¹	
3.5PC - 55	54.8	3.34	250	3625	280	4060	300	4350	2750	400
3.5PC - 64	63.2	3.85	250	3625	280	4060	300	4350	2750	350
3.5PC - 75	74.7	4.55	230	3335	250	3625	280	4060	2500	300
3.5PC - 87	88	5.36	210	3040	230	3330	260	3750	2250	300
3.5PC - 98*	99	6.03	200	2900	220	3190	250	3625	2000	300

*Displacement 98 are special release, please contact sales department.

**For working conditions, using exclusively pressure P¹, the value of max. speed must be reduced of 10%.

For bidirectional pump the max pressure has to be reduced of 10%.

The max pressure is referred to pumps with flanged ports, using the threaded ports the pump life could be reduced.

ROTATION CHANGING INSTRUCTIONS FOR UNITS

Before starting, be sure that the pump is cleaned externally as well as the working area to avoid that particles dangerous for pump working can find their way into the pump. Pump represented is a clockwise rotation pump.
To obtain an anti_clockwise rotation read carefully the following instructions.

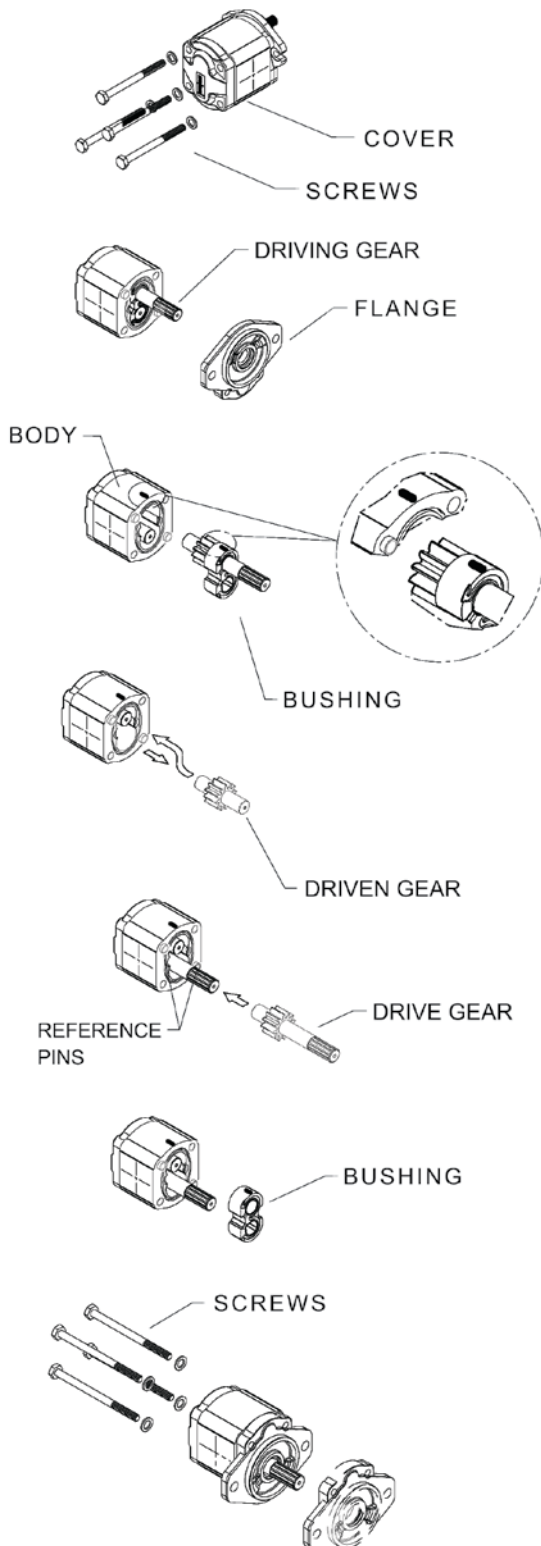

- 1 - Loosen and fully unscrew the screws.
- 2 - Lay the pump on the working area in order to have the mounting flange turned upside.
- 3 - Coat the shaft extension with grease to avoid damaging the shaft seal.
- 4 - Remove the flange and lay it on the working area; verify that the seal is correctly located in the body seat.

- 1 - Mark the position of the bushing and eventually the thrust plate, relative to the body.
- 2 - Remove the bushing, thrust plate and the driving gear taking care to avoid driven gear axial shifts.

- 1 - Draw out the driven gear from its housing, taking care to avoid rear cover axial shifts.
- 2 - Re-locate the driven gear in the position previously occupied by the driving gear.

- 1 - Re-locate the driving gear in the position previously occupied by the driven gear.

- 1 - Replace the bushing and thrust plate taking care that:
 - marks are located as on the picture
 - surface containing the seal is visible
 - seal and its protection are correctly located

- 1 - Clean body and mounting flange refaced surfaces.
- 2 - Verify that the two plugs are located in the body.
- 3 - Refit the mounting flange, turned 180° from its original position.
- 4 - Replace the clamp bolts and tighten crosswise evenly to a torque you will find at page 8.
- Check that the shaft rotates freely.
- 6 - Mark on the flange the new direction of rotation.

INDEX

Shafts And Flanges Combination	15
Assembling Dimensions And Working Conditions	16
Flanged And Threaded Ports.....	17
Drive Shafts	18
Mounting Flanges	19
Rear Covers With Relief Valve	20
Multiple Gear Pumps Assembling Dimensions.....	21
Performance Curves.....	22
How To Order Single Pumps	27
How To Order Multiple Pumps.....	28

Final revised edition-April 2017





The data in this catalogue refers to the standard product.

The policy of Salami S.p.A. consists of a continuous improvement of its products. It reserves the right to change the specifications of the different products whenever necessary and without giving prior information.

If any doubts, please get in touch with our sales department.

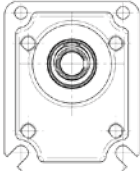
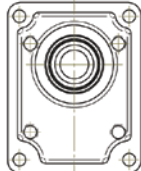
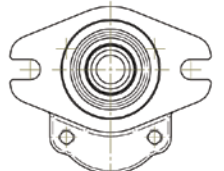
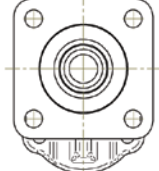

SHAFTS AND FLANGES COMBINATION

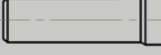
<p>1.5PE</p>	 CODE P0 - (Ø25,4 mm) European standard	 CODE P01 - (Ø30 mm) European standard	 CODE S0 - SAE AA 2 bolts	 CODE S1 - SAE AA 4 bolts
 CODE 18 - Tapered 1:8	18P0			
 CODE 19 - Tapered 1:8		19P01		
 CODE 51 - SAE A Splined 9T			51S0	
 CODE 80 - SAE AA Parallel Ø12,7			80S0	
 CODE 83 - SAE Parallel Ø12,7				83S1

EO.109.0417.02.001M02



Displacements up to 0.67 cu.in./rev
Pressure up to 4205 psi



GEAR PUMPS

Displacements up to 11 cm³/rev
Pressure up to 290 bar

ASSEMBLING DIMENSIONS AND WORKING CONDITIONS

Type		1.4	2.1	2.8	3.5	4.1	5.2	6.2	7.6	9.3	11
Displacement	cm ³ /rev	1.4	2.1	2.8	3.5	4.1	5.2	6.2	7.6	9.3	11
	cu.in./rev	0.09	0.13	0.17	0.21	0.25	0.32	0.38	0.46	0.57	0.67
Dimension A	mm	44	45.9	47.9	49.9	51.6	54.7	57.5	61.5	66.3	71.1
	in	1.73	1.81	1.89	1.96	2.03	2.15	2.26	2.42	2.61	2.80
Dimension C	mm	22	22.95	23.95	24.95	25.8	27.35	28.75	30.75	33.15	35.55
	in	0.87	0.90	0.94	0.98	1.02	1.08	1.13	1.21	1.31	1.40
Continuous pressure*	P ¹	bar	250	250	250	250	230	230	200	180	170
		psi	3625	3625	3625	3625	3335	3335	2900	2610	2465
Intermittent pressure	P ²	bar	270	270	270	270	250	250	220	200	190
		psi	3615	3615	3615	3615	3625	3625	3190	2900	2755
Peak pressure	P ³	bar	290	290	290	290	270	270	250	240	220
		psi	4205	4205	4205	4205	3915	3915	3925	3480	3190
Max speed at	P ²	rpm	5000	5000	4500	4500	4000	4000	3600	3300	3000
	P ¹	rpm	700	700	700	700	700	700	600	600	600
Weight	kg	1.25	1.27	1.30	1.34	1.37	1.42	1.45	1.52	1.59	1.66
	lbs	2.76	2.80	2.87	2.94	3.02	3.13	3.20	3.35	3.50	3.66

*For working conditions, using exclusively pressure P¹, the value of max. speed must be reduced of 10%.

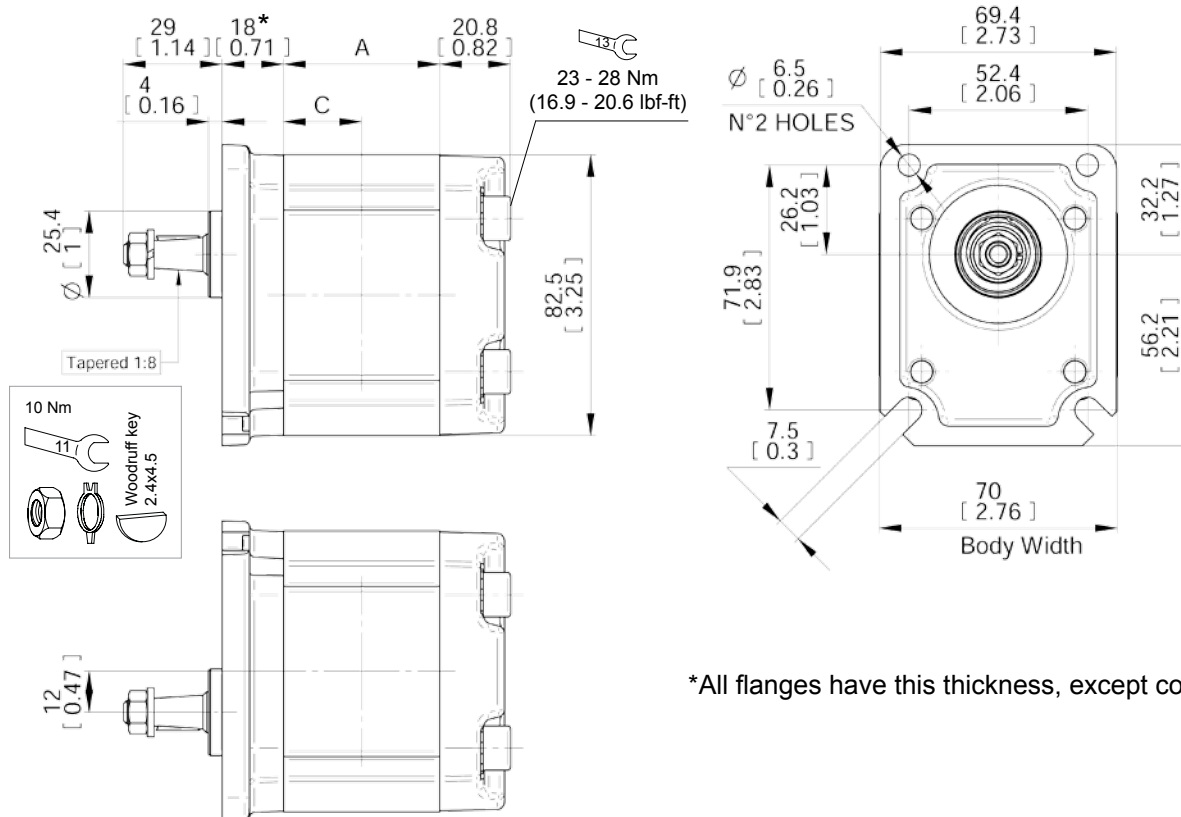

*All flanges have this thickness, except code S1.

E0.109.0417.02.001M02



FLANGED AND THREADED PORTS

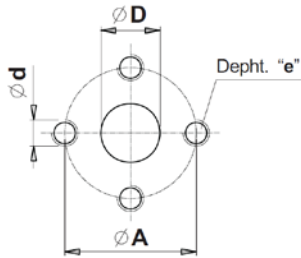

code P

Flanged ports
european standard

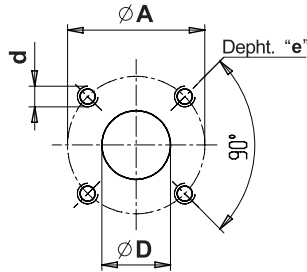

code B

Flanged ports
german standard

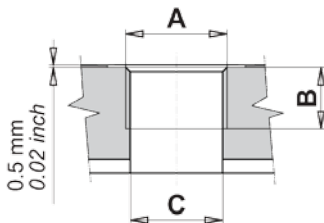

code G

Threaded ports
GAS (BSPP)

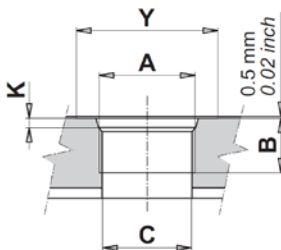

code R

Threaded ports
SAE (ODT)



UNI-DIRECTIONAL PUMP	TYPE	INLET				OUTLET			
		Ø D	Ø A	d	e	Ø D	Ø A	d	e
	From 1.4 to 11	13 (0.51")	30 (1.18")	M6	13 (0.51")	12 (0.47")	30 (1.18")	M6	13 (0.51")



BI-DIRECTIONAL PUMPS Special version available on request.



UNI-DIRECTIONAL PUMP	TYPE	INLET				OUTLET			
		Ø D	Ø A	d	e	Ø D	Ø A	d	e
	From 1.4 to 11	13 (0.51")	30 (1.18")	M6	13 (0.51")	12 (0.47")	30 (1.18")	M6	13 (0.51")



BI-DIRECTIONAL PUMPS Special version available on request.



UNI-DIRECTIONAL PUMP	TYPE	INLET			OUTLET		
		A	B	C	A	B	C
	From 1.4 to 6.2	G1/2	15 (0.59")	18 (0.71")	G3/8	13 (0.51")	13 (0.51")
	From 7.6 to 11				G1/2	15 (0.59")	



BI-DIRECTIONAL PUMPS Special version available on request.



UNI-DIRECTIONAL PUMP	TYPE	INLET					OUTLET				
		A	B	C	Y	K	A	B	C	Y	K
	From 1.4 to 6.2	3/4 -16 UNF (SAE 8)	14.5 (0.57")	13 (0.51")	30 (1.18")	2.5 (0.10")	9/16 - 18 UNF (SAE6)	13 (0.51")	25 (0.98")	2.5 (0.10")	
	From 7.6 to 11	7/8 -14 UNF (SAE10)	16.7 (0.66")	20 (0.79")	34 (1.34")	2.5 (0.10")	3/4 -16 UNF (SAE8)	14.5 (0.57")	15 (0.59")		30 (1.18")



BI-DIRECTIONAL PUMPS Special version available on request.

EO.109.0417.02.00IM02



DRIVE SHAFTS

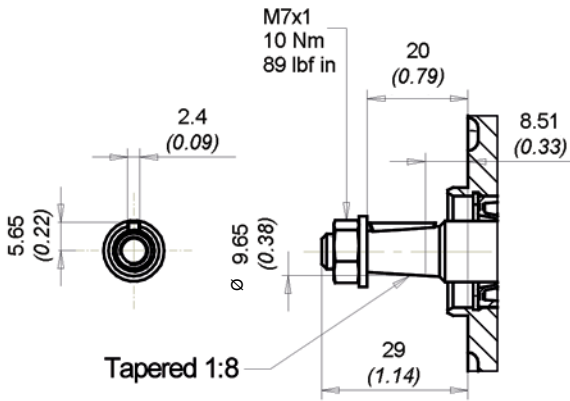

code 18 Max torque 35 Nm (310 lbf in)
European Tapered 1:8

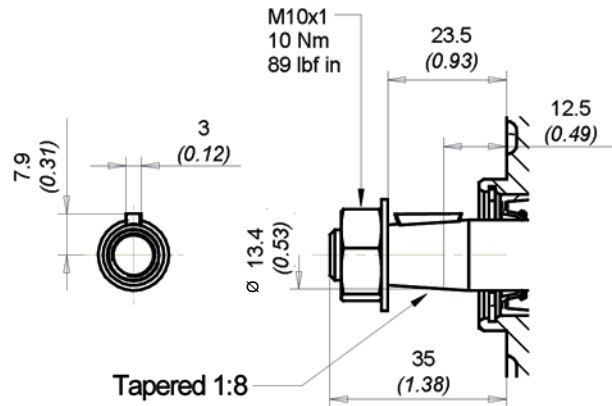

code 19 Max torque 60 Nm (531 lbf in)
European Tapered 1:8

Ext. Involute Spline ANSI B92.1
with major diameter modified
9 teeth - 20/40 Pitch - 30 deg
Flat Root - Side fit - Class 5

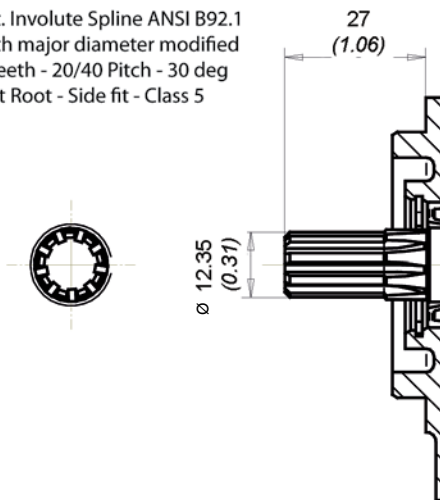

code 51 Max torque 50 Nm (442 lbf in)
SAE A Spline 9T

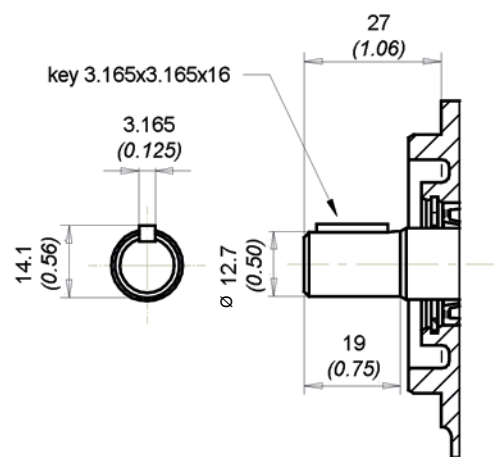

code 80 Max torque 40 Nm (354 lbf in)
SAE AA Parallel

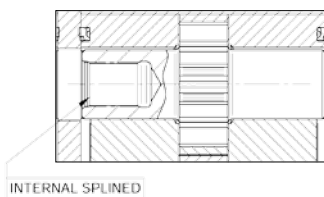

code 59 Max torque 30 Nm (266 lbf in)
DIN 5480 internal splined
(only for rear pumps)

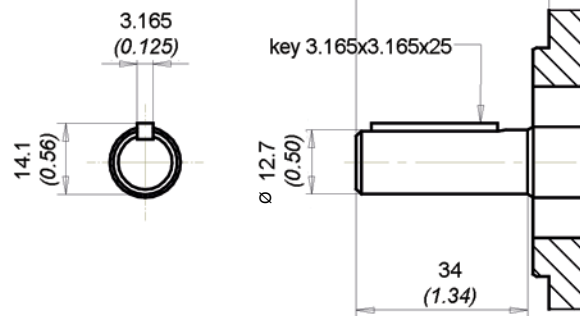

code 83 Max torque 40 Nm (354 lbf in)
SAE Parallel

E0.109.0417.02.001M02



MOUNTING FLANGES

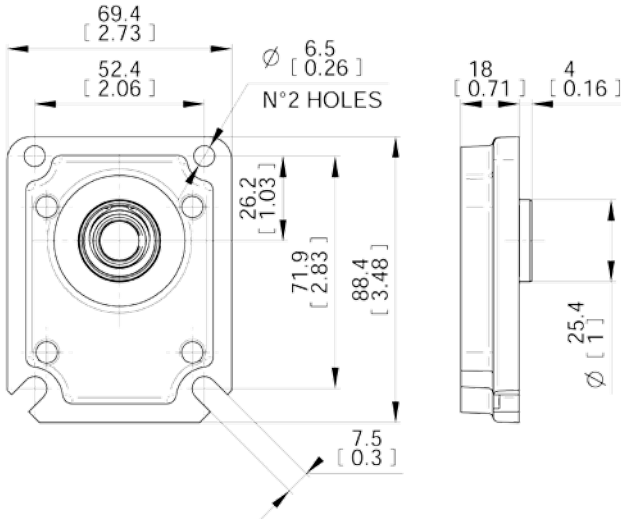

P0 European standard
With shaft code 18

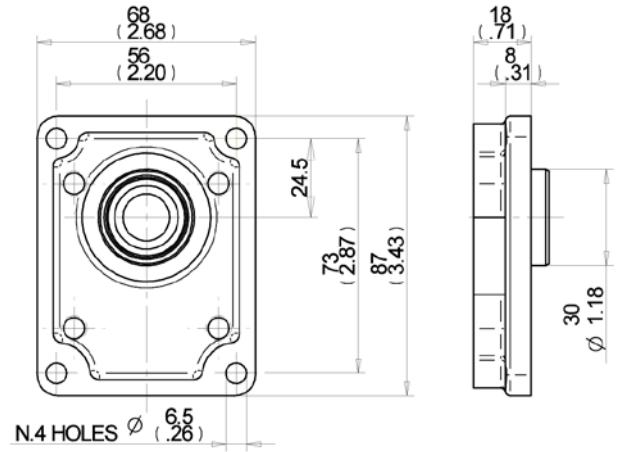

P01 European standard
With shaft code 19

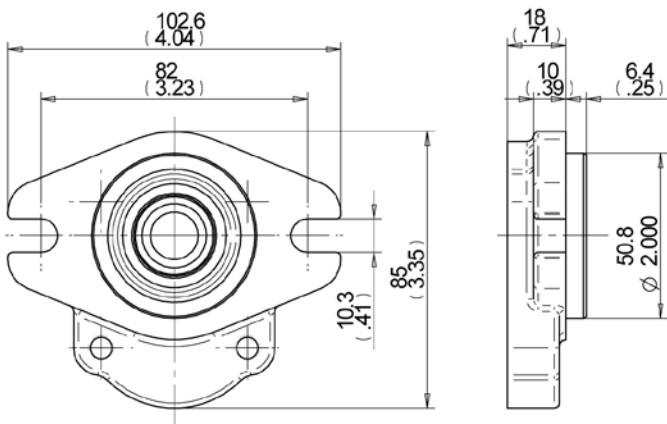

S0 SAE AA 2 bolts
With shaft code 51-80

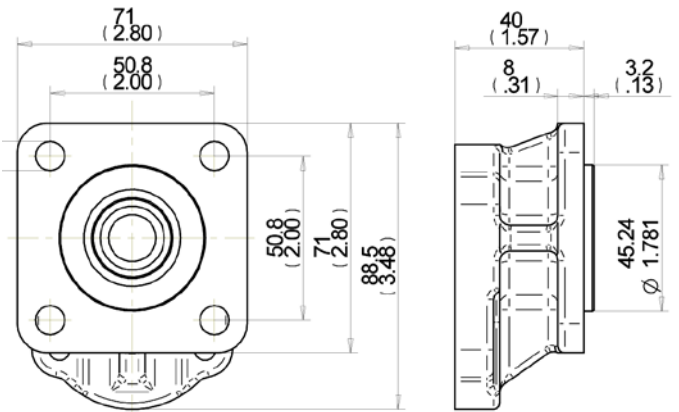

S1 SAE AA 4 bolts
With shaft code 83

EO.109.0417.02.001M02



REAR COVERS WITH RELIEF VALVE

code VS

With main relief valve
with internal unloading line.

Rear cover with fixed setting main relief valve.

Available values of fixed setting from 20 bar to 250 bar/290 psi-3625 psi
(Standard setting are multiple of 10 bar).

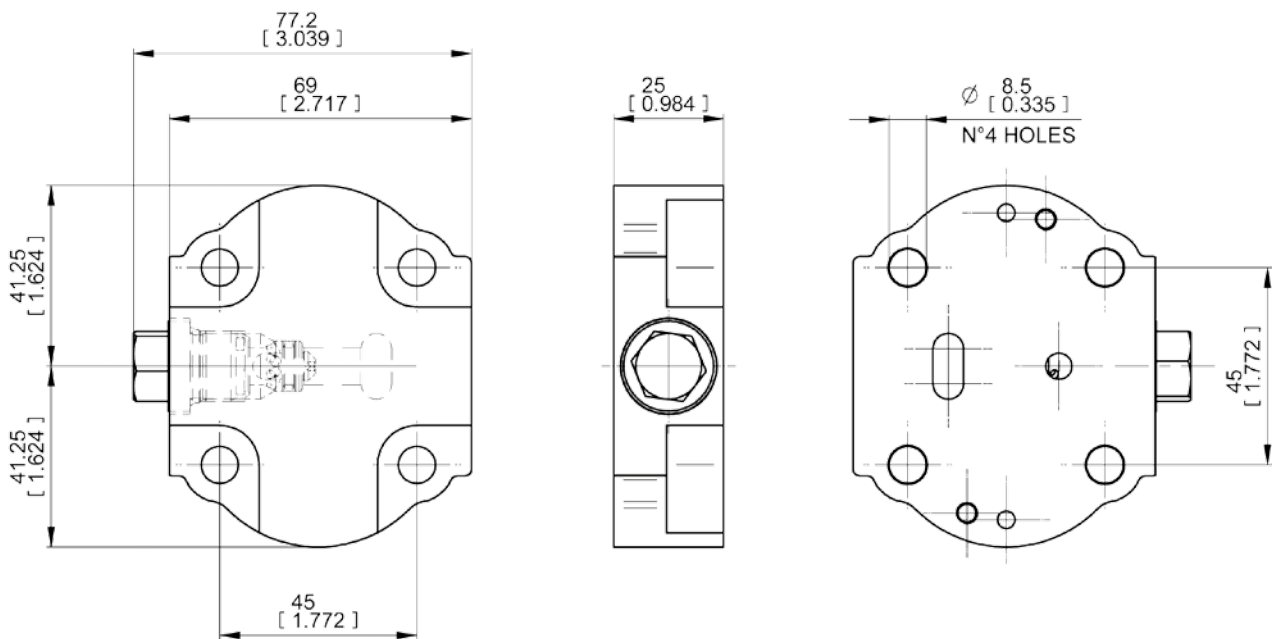
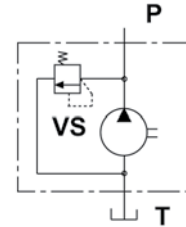

**MULTIPLE GEAR PUMPS
ASSEMBLING DIMENSIONS**

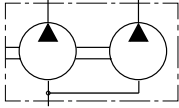

MULTIPLE GEAR PUMPS with common inlet port*

*In case of common inlet port, to avoid too high value of oil speed, 12 l/min is the max sucked flow for the downstream pump.

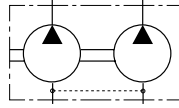

MULTIPLE GEAR PUMPS with inlet port on each body

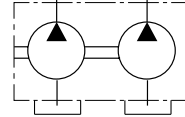

code AS

*On request multiple pump with separated stages.

Type		1.4	2.1	2.8	3.5	4.1	5.2	6.2	7.6	9.3	11
Dimension A	mm	44	45.9	47.9	49.9	51.6	54.7	57.5	61.5	66.3	71.1
	in	1.73	1.81	1.89	1.96	2.03	2.15	2.26	2.42	2.61	2.80
Dimension C	mm	22	22.95	23.95	24.95	25.80	27.35	28.75	30.75	33.15	35.55
	in	0.87	0.90	0.94	0.98	1.02	1.08	1.13	1.21	1.31	1.40

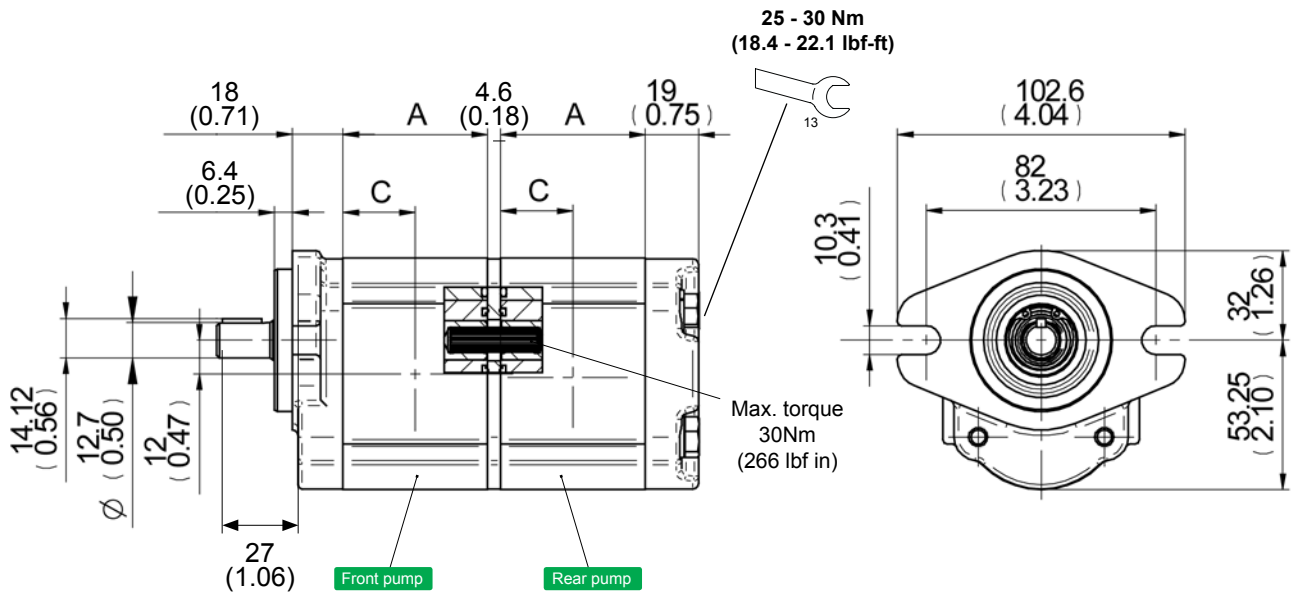

This is a Salami standard pump, alla drive shafts have a splined end.

These units are pre-arranged for multiple pumps, they have the drive shaft code 59.

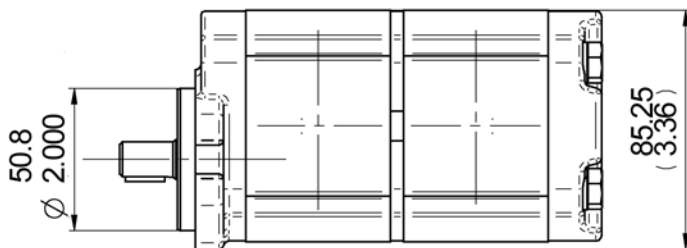

EO.109.0417.02.001M02



PERFORMANCE CURVES

Performance curves carried out with oil viscosity at 21 cSt and oil temperature at 50°C.
The performance of these diagrams are approximate. In case you need approved values, please contact our technical department.

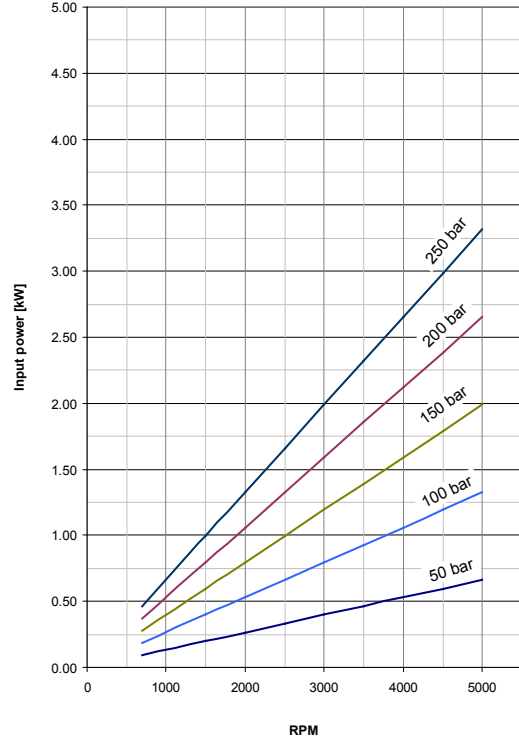
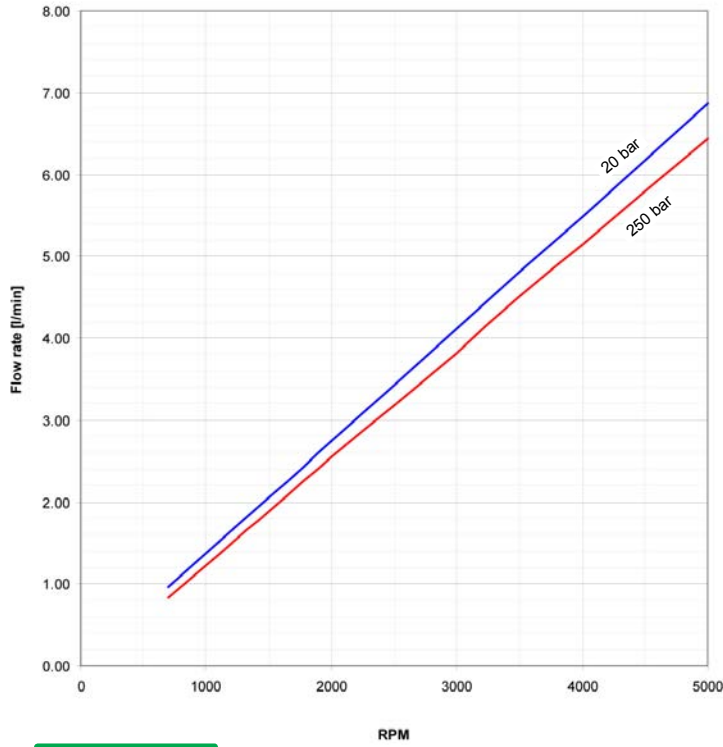

1.5PE - 1.4

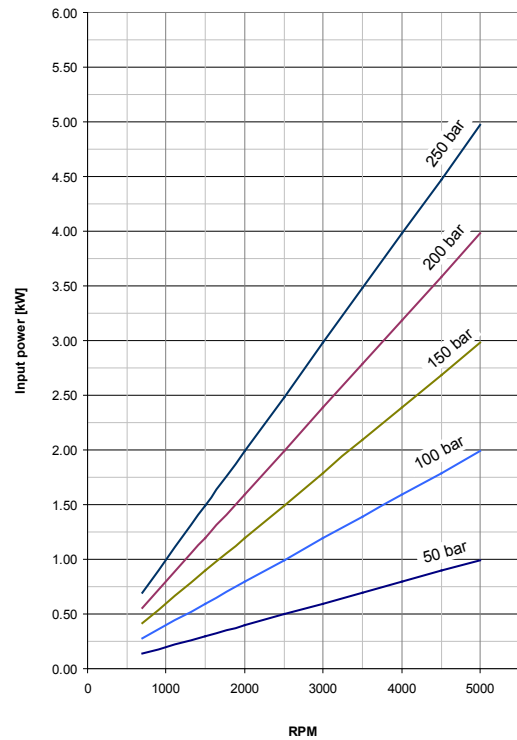
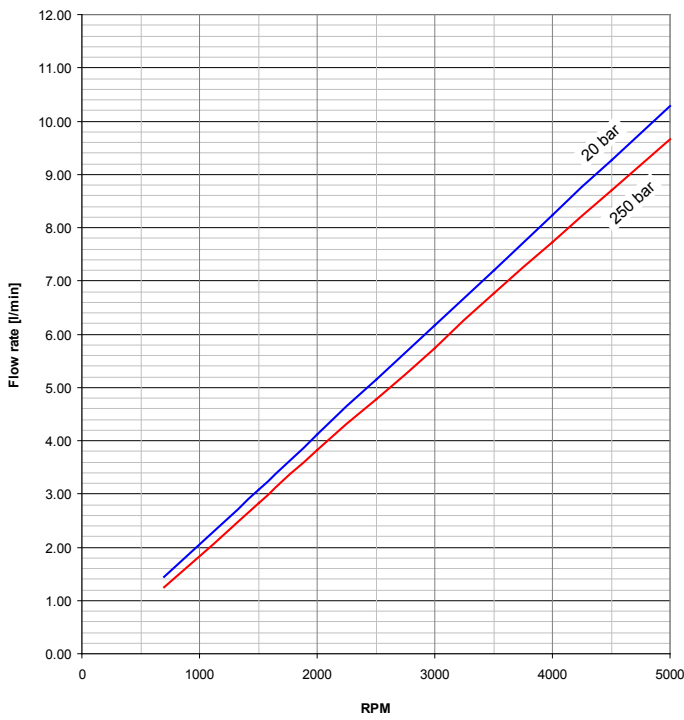

1.5PE - 2.1

E0.109.0417.02.001M02



PERFORMANCE CURVES

Performance curves carried out with oil viscosity at 21 cSt and oil temperature at 50°C.
The performance of these diagrams are approximate. In case you need approved values, please contact our technical department.

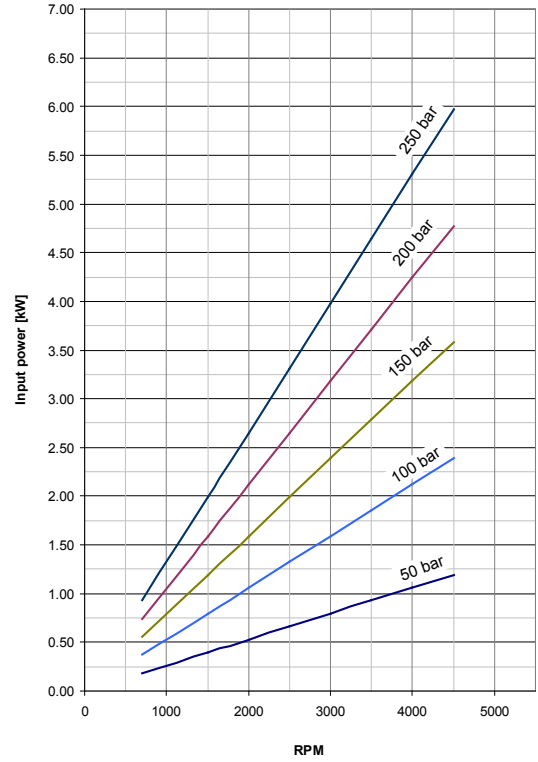
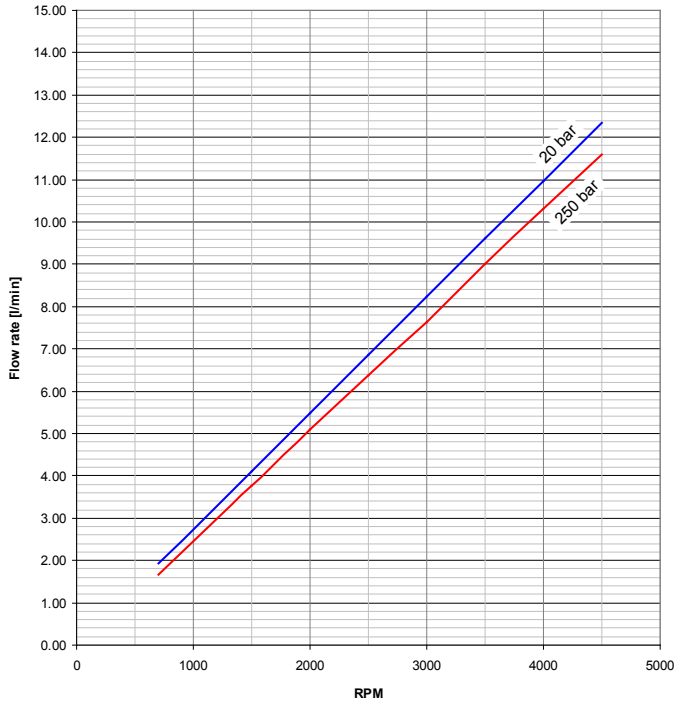

1.5PE - 2.8

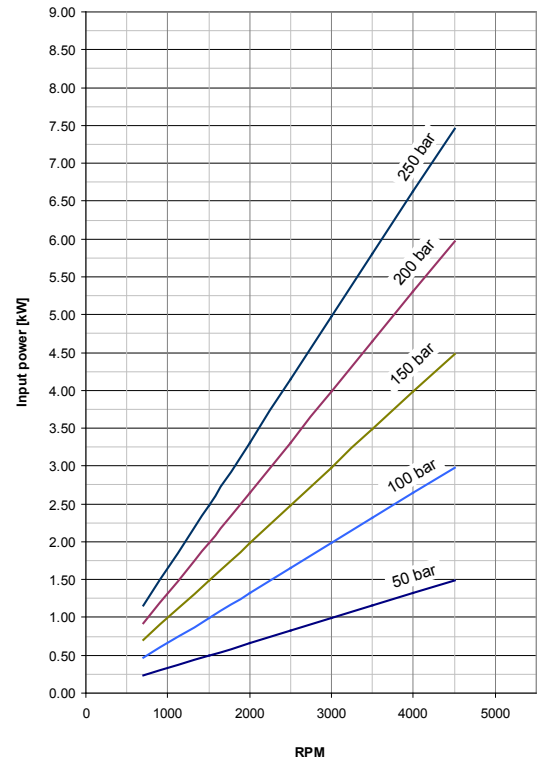
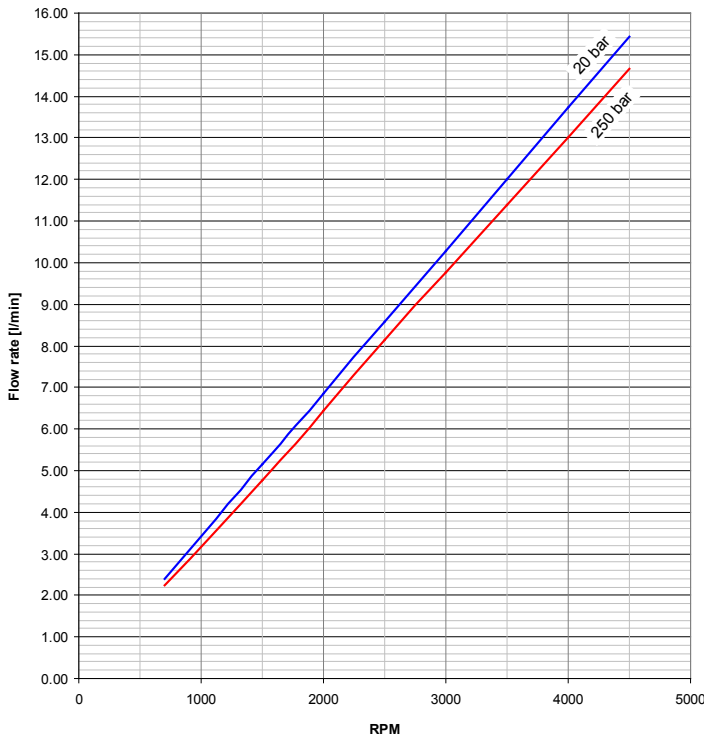

1.5PE - 3.5

EO.109.0417.02.001M02



PERFORMANCE CURVES

Performance curves carried out with oil viscosity at 21 cSt and oil temperature at 50°C.
The performance of these diagrams are approximate. In case you need approved values, please contact our technical department.

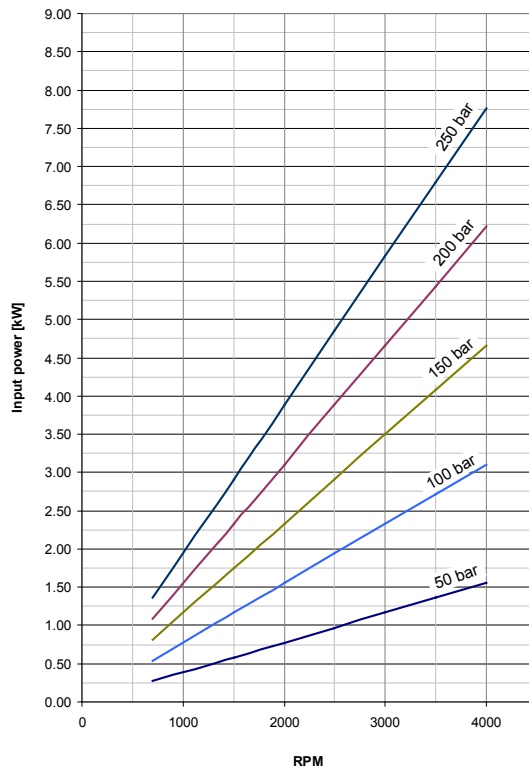
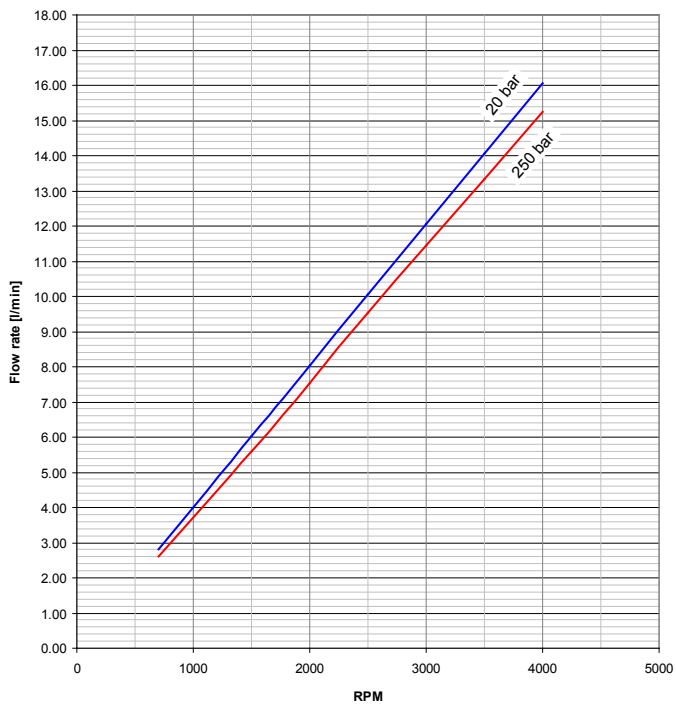

1.5PE - 4.1

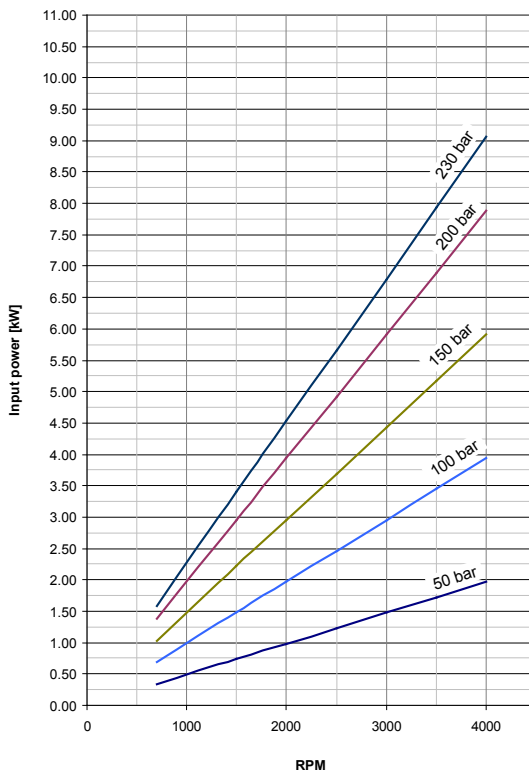
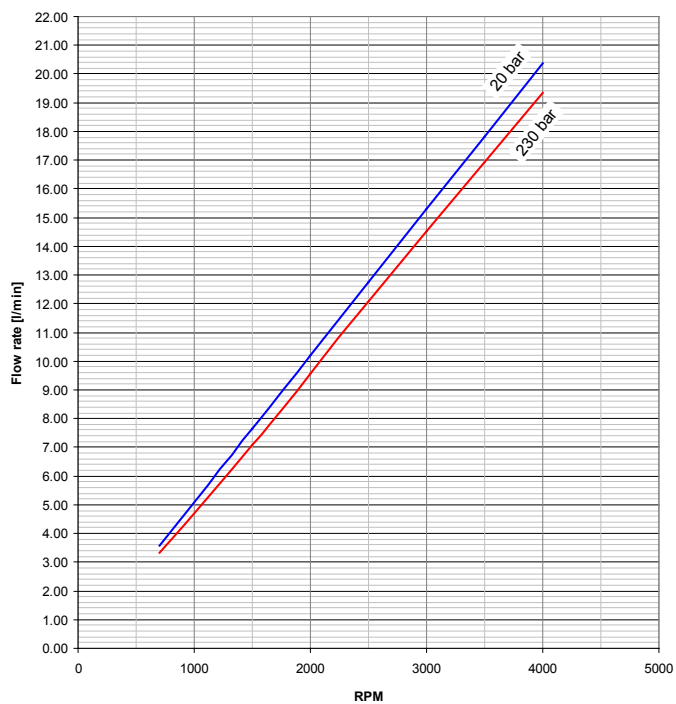

1.5PE - 5.2

E0.109.0417.02.00IM02



PERFORMANCE CURVES

Performance curves carried out with oil viscosity at 21 cSt and oil temperature at 50°C.
The performance of these diagrams are approximate. In case you need approved values, please contact our technical department.

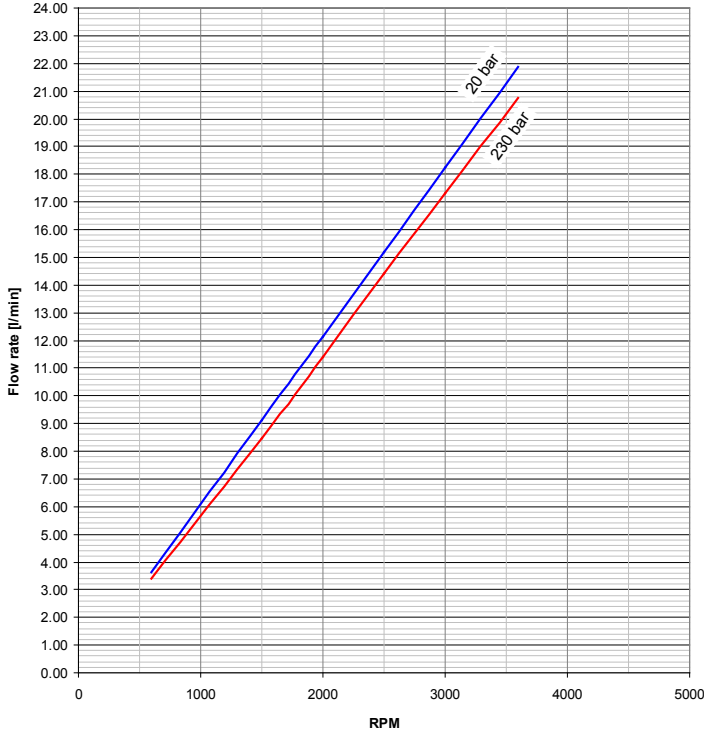

1.5PE - 6.2

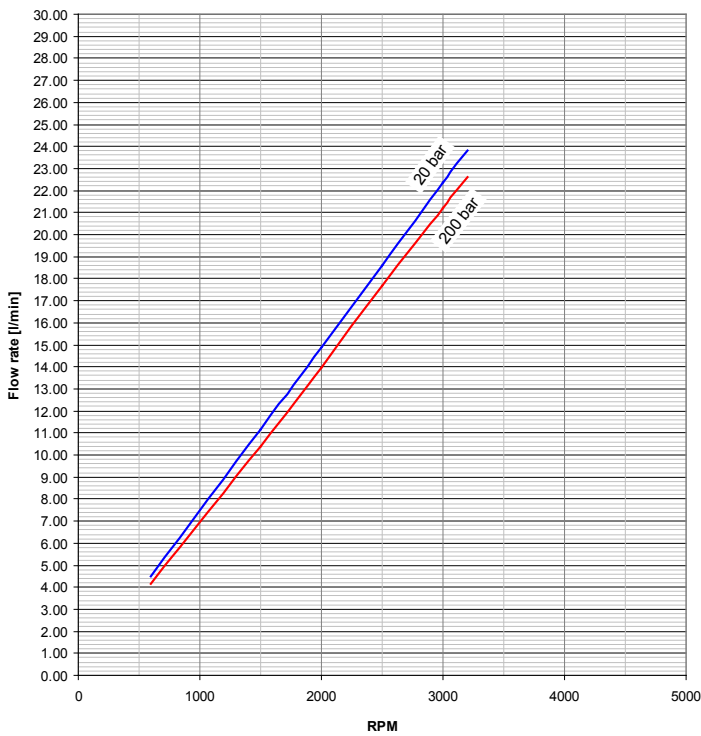
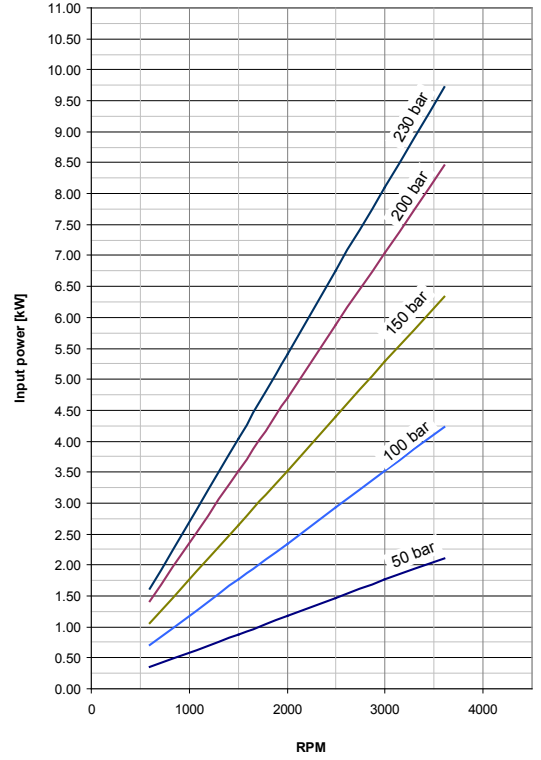

1.5PE - 7.6

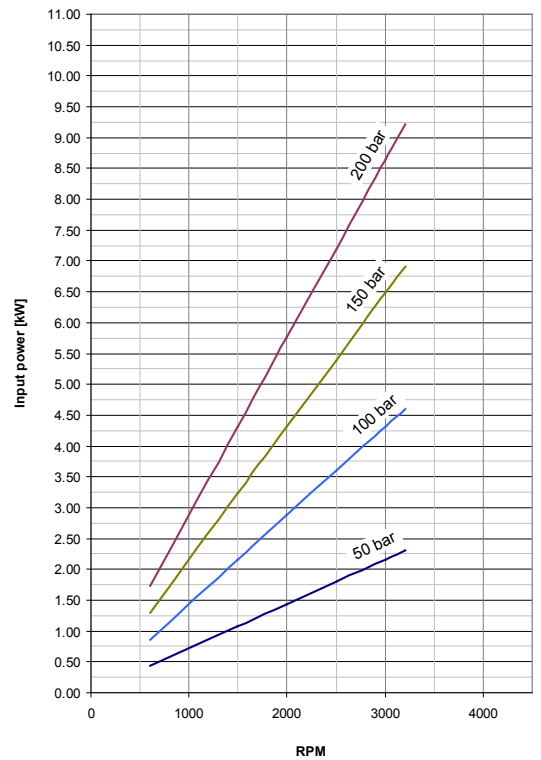

EO.109.0417.02.00IM02



PERFORMANCE CURVES

Performance curves carried out with oil viscosity at 21 cSt and oil temperature at 50°C.
The performance of these diagrams are approximate. In case you need approved values, please contact our technical department.

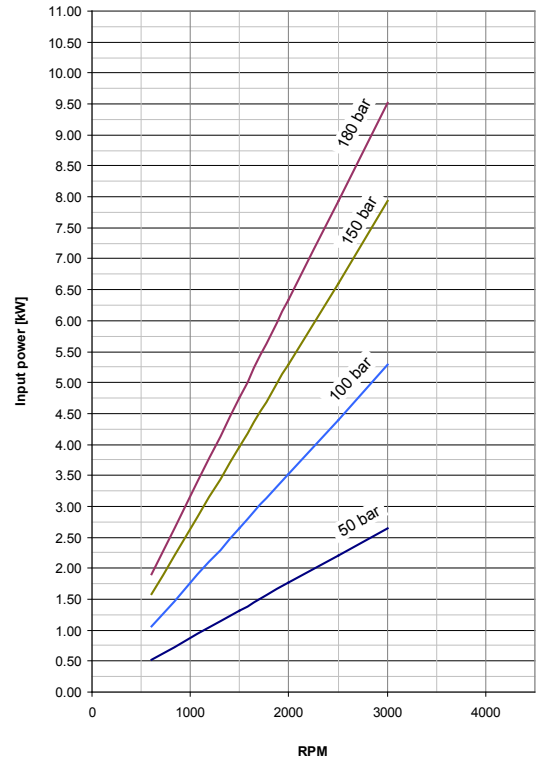
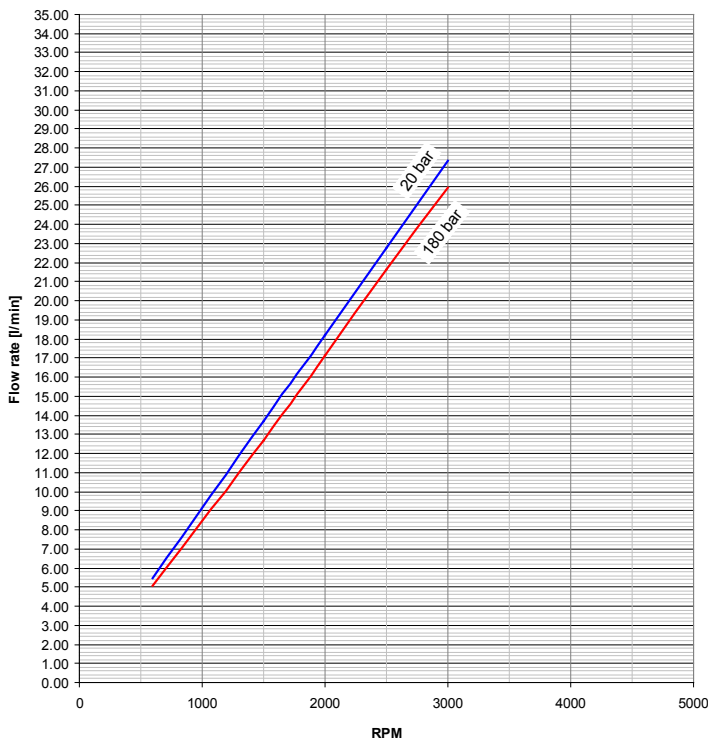

1.5PE - 9.3

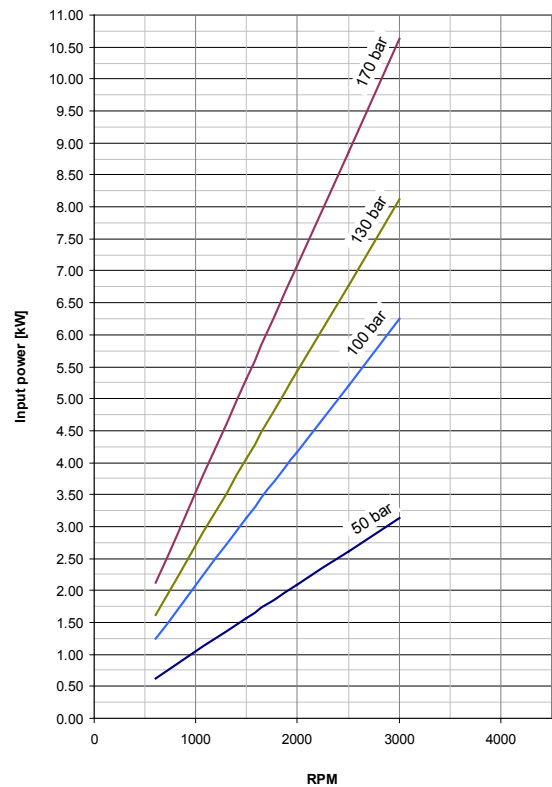
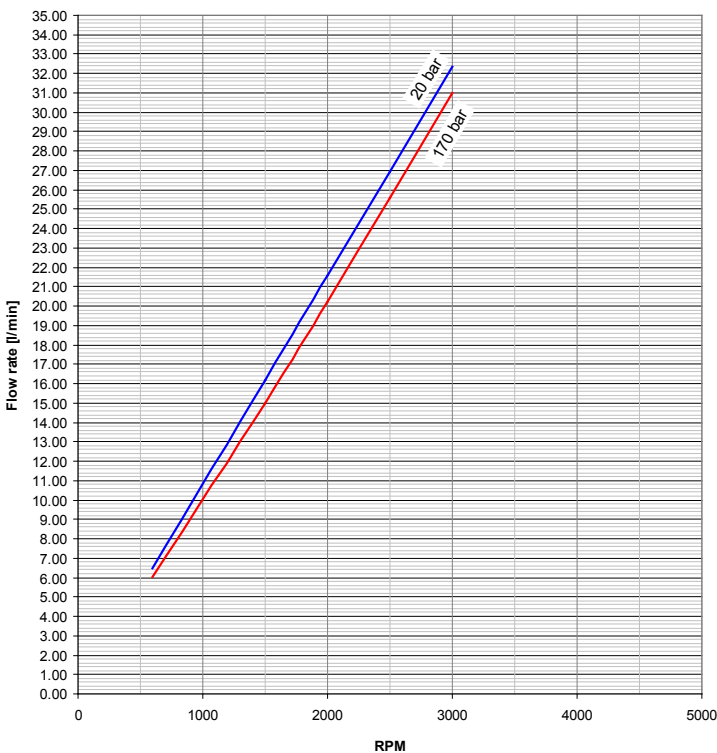

1.5PE - 11

E0.109.0417.02.00IM02



SINGLE PUMPS

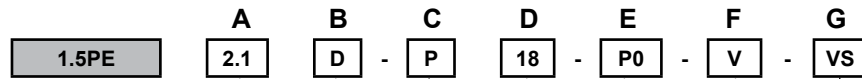

TYPE	DISPLACEMENTS		A
1.4	1.4 cm ³ /rev.	0.09 cu.in/rev.	
2.1	2.1 cm ³ /rev.	0.13 cu.in/rev.	
2.8	2.8 cm ³ /rev.	0.17 cu.in/rev.	
3.5	3.5 cm ³ /rev.	0.21 cu.in/rev.	
4.1	4.1 cm ³ /rev.	0.25 cu.in/rev.	
5.2	5.2 cm ³ /rev.	0.32 cu.in/rev.	
6.2	6.2 cm ³ /rev.	0.38 cu.in/rev.	
7.6	7.6 cm ³ /rev.	0.46 cu.in/rev.	
9.3	9.3 cm ³ /rev.	0.57 cu.in/rev.	
11	11 cm ³ /rev.	0.67 cu.in/rev.	

ROTATION (page 6)	CODES	B
Clockwise	D	
Anti-clockwise	S	
Reversible	R	

PORTS (page 17)	CODES	C
Flanged ports european standard	P	
Flanged ports german standard	B	
Threaded ports GAS (BSPP)	G	
Threaded ports SAE (ODT)	R	

DRIVE SHAFTS (page 18)	CODES	D
European Tapered 1:8	18	
European Tapered 1:8	19	
SAE A splined 9T	51	
DIN 5480 internal splined (only for rear pumps- see page 21)	59	
SAE AA parallel Ø12,7	80	
SAE parallel Ø12,7	83	

G	VALVES IN THE COVER (page 20)	CODE
	Fixed main relief valve	VS

F	SEALS	CODE
	Nitrile-butadiene rubber (nbr)	
	Viton	V

E	MOUNTING FLANGES (page 19)	CODES
	European standard	P0
	European standard	P01
	SAE AA (2 bolts)	S0
	SAE AA (4 bolts)	S1

Order example 1.5PE 6.2D, ports European standard (P), drive shaft (51), mounting flange (P0)
1.5PE6.2D-P51P0

EO.109.0417.02.00IM02



MULTIPLE PUMPS



Order example 1.5PE 6.2 - 4.1D, ports GAS (G), drive shaft (19), mounting flange (P01).

1.5PE6.2/4.1D-G19P01

*UA: this type of multiple pump is a Salami standard multiple pump which has only one inlet port opened, all the other inlet port are closed.

In case of common suction, the code 1 - 2 or 3, correspond to the body where inlet is located.



You can find our most up to date “STANDARD SALES CONDITIONS” on our website.

Potete trovare le nostre più aggiornate “CONDIZIONI DI VENDITA STANDARD”
sul nostro sito.

www.salami.it

T. +39 059 387 411

sales@salami.it

Watch our tutorials on youtube channel



Salami Fluid Power
Salami Fluid Power World
Salami Fluid Power France
Salami Fluid Power España
Salami Fluid Power Deutsch

SALAMI S.P.A.

Via Emilia Ovest 1006
41121 Modena (Italy)
T. +39 059 387 411
F. +39 059 387 639
sales@salami.it

SALAMI ESPAÑA

Poligono Industrial Armenteres
C/Primer de Maig, 18, Nave 4
08980 San Feliu de Llobregat
Barcelona
T. +34-93-6665451
F. +34-93-6667826
info@salamispain.com

SALAMI FRANCE

22, rue Louis Saillant
69120 Valux en Velin
Lyon
T. +33-04-78809941
F. +33-04-78803669
e.pasian@salami.fr

SALAMI HYDRAULICS N.A INC

4630 Crossroads Park Drive
Liverpool
NY 13088 - USA
T. +1-315-295-2363
F. +1-315-295-2364
info@salamihydraulics.com