

---

# 1.5ME

---

## Aluminium gear motors

---

### Technical Catalogue

---

E0.109.0417.02.00IM01





**GEAR MOTORS**

- Displacements from 2.8 cm<sup>3</sup>/rev to 73.4 cm<sup>3</sup>/rev (from 0.17 cu.in./rev to 4.48 cu.in./rev).
- Rated pressure up to 250 bar (3625psi).
- Back pressure capability up to 120 bar (1740 psi) only in bi-directional release.
- Speed up to 4500 rpm.
- Flanges, shafts and ports for ISO, DIN and SAE standards.
- Available in uni and bi-directional version for all the sizes, displacements and configurations.
- High volumetric efficiency thanks to an innovative design and an accurate control of machining tolerances.
- Axial compensation achieved by the use of floating bushes that allow high volumetric efficiency throughout the working pressure range.
- DU bearings to ensure high pressure capability.
- 12 teeth integral gear and shaft.
- Aluminium body.
- Cast iron flange and cover.
- Double shaft seals in all motor series. The one which faces the internal side is reinforced.
- Nitrile seals as standard and Viton seals in high temperature applications.
- Available with different valves and circuit configurations built-in rear cover.
- All motors are hydraulically tested after assembly to ensure the highest standard performance.

**TECHNICAL DATA**

- Minimum operating fluid viscosity	12 mm <sup>2</sup> /sec
- Permitted viscosity range	12 - 800 mm <sup>2</sup> / sec
- Recommended viscosity range	20 - 80 mm <sup>2</sup> / sec
- Permitted viscosity for starting	2000 mm <sup>2</sup> / sec
- Fluid operating temperature range	-25 to 85 °C
- Fluid operating temperature range with FPM seals	-20 to 110°C
- Fluid operating temperature range with HNBR seals*	-30 to 110°C
- Hydraulic fluid	mineral oil

\*Available on request

**DEFINITION OF PRESSURES**

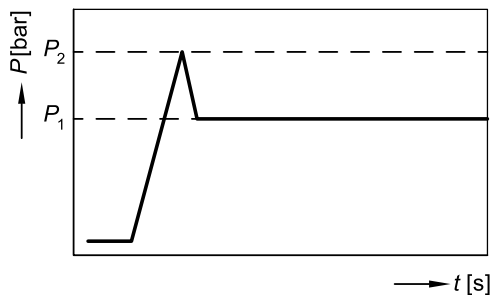

$P_1$  max. continuous pressure  
 $P_2$  starting pressure (depending on the application, this must be taken into consideration when setting the pressure of the hydraulic system's pressure-relief valve).

EO.100.0417.02.001M01



## DRIVE SHAFTS

Radial and axial loads on the shafts must be avoided since they reduce the life of the unit. In order to avoid misalignment during the assembly with the primary engine, a connection with "Oldham" coupling (or coupling having convex toothed hub) is recommended.

## ROTATION

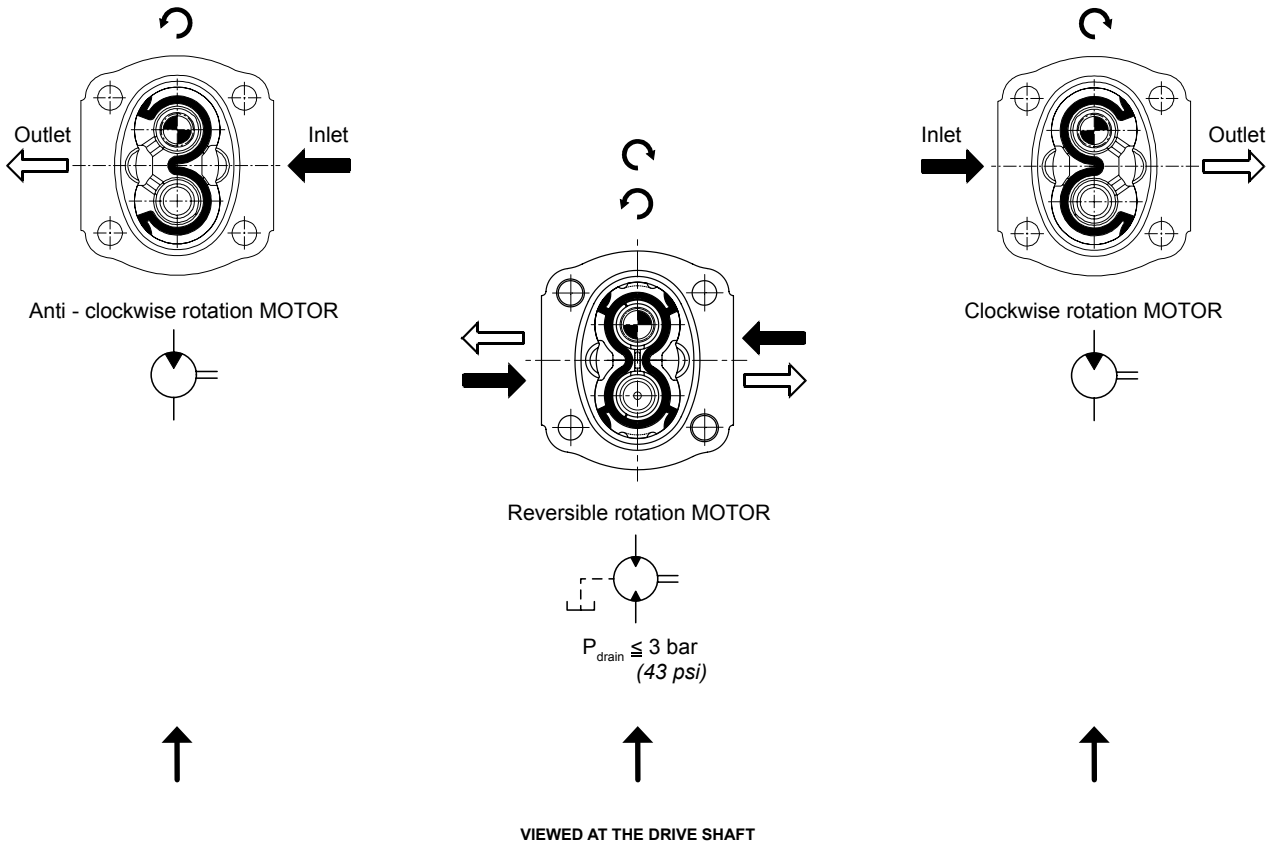

## HYDRAULIC PIPE LINE

To calculate hydraulic pipe line size, the designer can use; as an approximate guide, the following fluid speed figures:

From 6 to 10 m/sec on pressure pipe line

From 19.7 to 32.8 ft/sec on pressure pipe line

The lowest fluid speed values in pipe lines is recommended when the operating temperature range is high and/or for continuous duty.

The highest value is recommended when the temperature difference is low and/or for intermittent duty.

In case of reversible motor allowance must be made to ensure the motor is not drained, through the case drain, when stationary.

**FILTRATION INDEX RECOMMENDED**

Working pressure	>200 bar/2900 psi	<200 bar/2900 psi
Contamination class NAS 1638	9	10
Contamination class ISO 4406	19/18/15	20/19/16
Achieved with filter $\beta_x=75$	15 $\mu\text{m}$	25 $\mu\text{m}$

**FIRE RESISTENT FLUID**

Type	Description	Max pressure	Max speed (rpm)	Temperature
HFB	Oil emulsion with 40% water	130 bar/1880 psi	2500	3°C+65°C
HFC	Water glycol	180 bar/2600 psi	1500	-20°C+65°C
HFD	Phosphate esters		1750	-10°C+80°C

**COMMON FORMULAS FOR MOTORS**

Based on SI units

Input flow:  $Q = \frac{V \cdot n}{1000 \cdot \eta_v}$  l/min

Output torque:  $M = \frac{V \cdot \Delta p \cdot \eta_m}{20 \cdot \pi}$  Nm

Output power:  $P = \frac{M \cdot n}{9550} = \frac{Q \cdot \Delta p \cdot \eta_t}{600}$  kW

Variables: SI units [US units]

Based on US units

Input flow:  $Q = \frac{V \cdot n}{231 \cdot \eta_v}$  [US gal/min]

Output torque:  $M = \frac{V \cdot \Delta p \cdot \eta_m}{2 \cdot \pi}$  [lbf·in]

Output power:  $P = \frac{M \cdot n}{63\,025} = \frac{Q \cdot \Delta p \cdot \eta_t}{1714}$  [hp]

LEGENDA

- V = Displacement cm<sup>3</sup>/rev [in<sup>3</sup>/rev]
- $P_{out}$  = Outlet pressure bar [psi]
- $P_{in}$  = Inlet pressure bar [psi]
- $\Delta P$  =  $P_{out} - P_{in}$  (system pressure) bar [psi]
- n = Speed min<sup>-1</sup> (rpm)
- $\eta_v$  = Volumetric efficiency
- $\eta_m$  = Mechanical efficiency
- $\eta_t$  = Overall efficiency ( $\eta_v \cdot \eta_m$ )

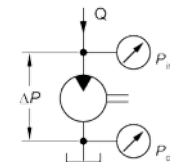

**IDENTIFICATION LABEL**

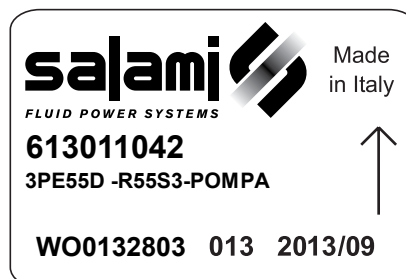

Salami part number \_\_\_\_\_  
Product short description \_\_\_\_\_

Rotation sense ↑

Product code (for Salami management) \_\_\_\_\_

Month and year of made \_\_\_\_\_  
Number of assembling \_\_\_\_\_

EO.100.0417.02.001M01



## WORKING CONDITIONS

GROUP 1.5 - E SERIES	Displacement		Max. continuous pressure P <sup>1</sup>		Max. starting pressure P <sup>2</sup>		Max. speed	Min. speed
	cm <sup>3</sup> /rev	cu.in/rev	bar	psi	bar	psi		
1.5ME - 2.8	2.8	0.17	250	3625	270	3915	4500	700
1.5ME - 3.5	3.5	0.21	250	3625	270	3915	4500	700
1.5ME - 4.1	4.1	0.25	250	3625	270	3915	4000	700
1.5ME - 5.2	5.2	0.32	230	3335	250	3625	4000	700
1.5ME - 6.2	6.2	0.38	230	3335	250	3625	3600	600
1.5ME - 7.6	7.6	0.46	200	2900	220	3190	3300	600
1.5ME - 9.3	9.3	0.57	180	2610	200	2900	3000	600
1.5ME - 11	11	0.67	170	2465	190	2755	3000	600

GROUP 2 - E SERIES	Displacement		Max. continuous pressure P <sup>1</sup>		Max. starting pressure P <sup>2</sup>		Max. speed	Min. speed
	cm <sup>3</sup> /rev	cu.in/rev	bar	psi	bar	psi		
2ME - 4.5	4.6	0.27	250	3625	280	4060	4000	600
2ME - 6.5	6.5	0.4	250	3625	280	4060	4000	600
2ME - 8.3	8.2	0.5	250	3625	280	4060	3600	500
2ME - 10.5*	10.6	0.65	250	3625	280	4060	3500	500
2ME - 11.3	11.5	0.68	250	3625	280	4060	3500	500
2ME - 12.5*	12.7	0.77	250	3625	280	4060	3400	500
2ME - 13.8	13.8	0.84	250	3625	280	4060	3400	500
2ME - 16	16.6	1.01	250	3625	280	4060	3200	450
2ME - 19	19.4	1.15	220	3190	240	3480	3200	450
2ME - 22.5	22.9	1.37	200	2900	220	3190	3000	450
2ME - 26	25.8	1.58	180	2610	200	2900	2850	450

\*Available for quantity

GROUP 2.5 - B SERIES	Displacement		Max. continuous pressure P <sup>1</sup>		Max. starting pressure P <sup>2</sup>		Max. speed	Min. speed
	cm <sup>3</sup> /rev	cu.in/rev	bar	psi	bar	psi		
2.5MB - 16	16	0.97	250	3625	280	4060	3000	600
2.5MB - 19	19.3	1.17	250	3625	280	4060	3000	600
2.5MB - 22	22.2	1.35	250	3625	280	4060	3000	500
2.5MB - 25	25.2	1.53	250	3625	280	4060	3000	500
2.5MB - 28	27.6	1.68	250	3625	280	4060	3000	500
2.5MB - 32	32.4	1.97	230	3330	250	3625	3000	500
2.5MB - 38	38.1	2.32	200	2900	220	3190	2750	400
2.5MB - 44	44.2	2.69	170	2465	190	2755	2500	400

GROUP 3 - E SERIES	Displacement		Max. continuous pressure P <sup>1</sup>		Max. starting pressure P <sup>2</sup>		Max. speed	Min. speed
	cm <sup>3</sup> /rev	cu.in/rev	bar	psi	bar	psi		
3ME - 27	27	1.65	250	3625	280	4060	3000	600
3ME - 33	33.5	2.04	250	3625	280	4060	3000	600
3ME - 38	38.7	2.36	250	3625	280	4060	2750	500
3ME - 46	46.9	2.86	250	3625	270	3915	2750	500
3ME - 55	54.1	3.3	220	3190	240	3480	2500	400
3ME - 65	63.1	3.85	200	2900	220	3190	2500	400
3ME - 75*	73.4	4.48	180	2610	200	2900	2500	400

\*Available for quantity

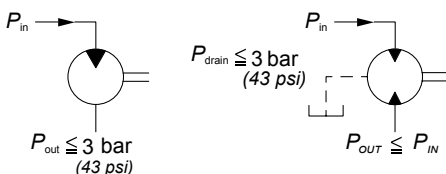

The values shown in the picture represents the standard working situation.  
 Max drain pressure is influenced by rotational speed of the unit.  
 For pressure higher than 3 bar please contact sales department.  
**On request available shaft seal for high P drain (20 bar).**

E0.100.0417.02.00IM01



---

**INDEX**

---

Shafts And Flanges Combination .....	139
Assembling Dimensions And Working Conditions.....	140
Flanged And Threaded Ports.....	141
Drive Shafts .....	142
Mounting Flanges .....	143
Rear Covers With Relief Valve .....	144
Performance Curves.....	145
How To Order Single Motors .....	148

**Final revised edition-April 2017**

The data in this catalogue refers to the standard product.

The policy of Salami S.p.A. consists of a continuous improvement of its products. It reserves the right to change the specifications of the different products whenever necessary and without giving prior information.





***If any doubts, please get in touch with our sales department.***





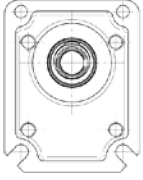
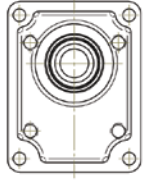
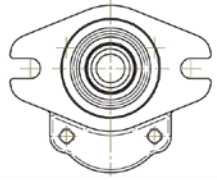
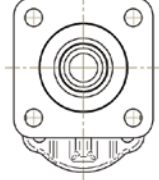

**SHAFTS AND FLANGES COMBINATION**

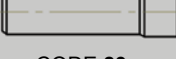
<p><b>1.5ME</b></p>	 CODE <b>P0</b> - (Ø25,4 mm) European standard	 CODE <b>P01</b> - (Ø30 mm) European standard	 CODE <b>S0</b> - SAE AA 2 bolts	 CODE <b>S1</b> - SAE AA 4 bolts
 CODE <b>18</b> - Tapered 1:8	<p>18P0</p>			
 CODE <b>19</b> - Tapered 1:8		<p>19P01</p>		
 CODE <b>51</b> - SAE A Splined 9T			<p>51S0</p>	
 CODE <b>80</b> - SAE AA Parallel Ø12,7			<p>80S0</p>	
 CODE <b>83</b> - SAE Parallel Ø12,7				<p>83S1</p>

EO.109.0417.02.00IM01

Displacements up to 0.67 cu.in./rev  
Pressure up to 3625 psi

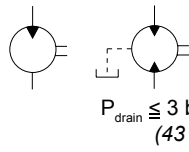

GEAR MOTORS

Displacements up to 11 cm³/rev  
Pressure up to 250 bar

## ASSEMBLING DIMENSIONS AND WORKING CONDITIONS

Type		2.8	3.5	4.1	5.2	6.2	7.6	9.3	11
Displacement	cm³/rev	2.8	3.5	4.1	5.2	6.2	7.6	9.3	11
	cu.in./rev	0.17	0.21	0.25	0.32	0.38	0.46	0.57	0.67
Dimension A	mm	47.9	49.9	51.6	54.7	57.5	61.5	66.3	71.1
	in	1.89	1.96	2.03	2.15	2.26	2.42	2.61	2.80
Dimension C	mm	23.95	24.95	25.8	27.35	28.75	30.75	33.15	35.55
	in	0.94	0.98	1.02	1.08	1.13	1.21	1.31	1.40
Max continuous pressure	P <sup>1</sup> bar	250	250	250	230	230	200	180	170
	psi	3625	3625	3625	3335	3335	2900	2610	2465
Max starting pressure	P <sup>2</sup> bar	270	270	270	250	250	220	200	190
	psi	3915	3915	3915	3625	3625	3190	2900	2755
Max speed at	P <sup>2</sup> rpm	4500	4500	4000	4000	3600	3300	3000	3000
Min speed at	P <sup>1</sup> rpm	700	700	700	700	600	600	600	600
Weight	kg	1.30	1.34	1.37	1.42	1.45	1.52	1.59	1.66
	lbs	2.87	2.94	3.02	3.13	3.20	3.35	3.50	3.66

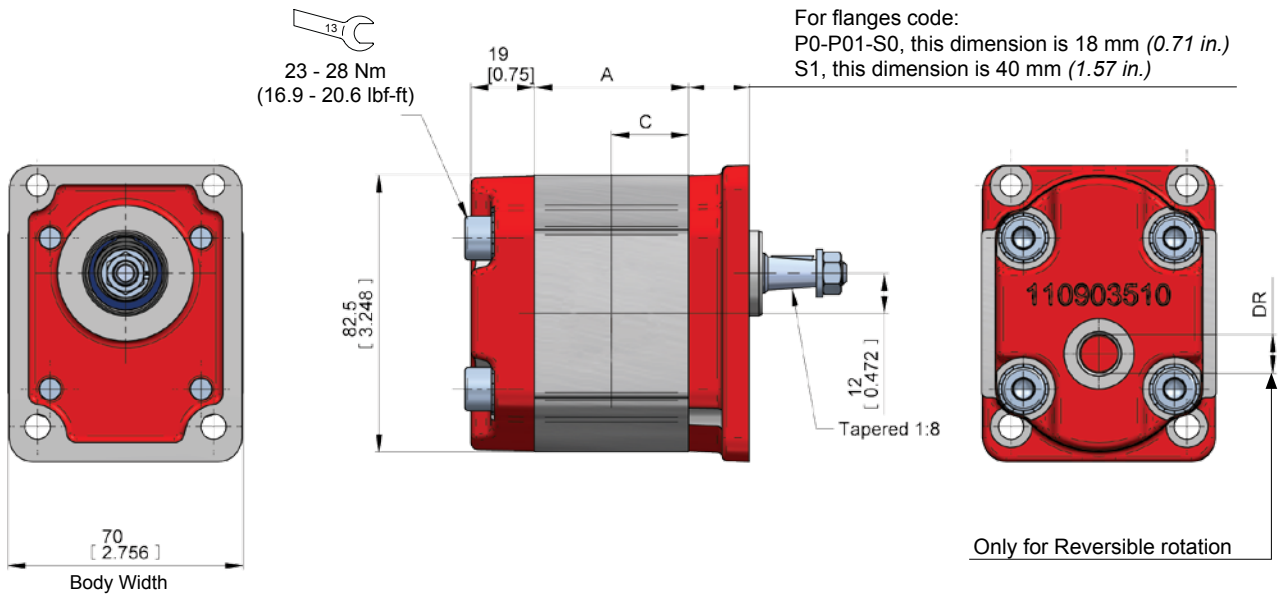

E0.109.0417.02.001M01



**FLANGED and THREADED PORTS**

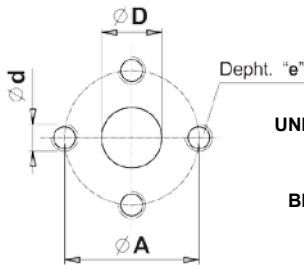

**code P**

Flanged ports  
european standard

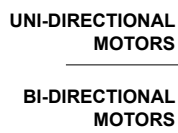

TYPE	OUTLET				INLET				DRAIN*
	Ø D	Ø A	d	e	Ø D	Ø A	d	e	DR
From 2.8 to 11	13 (0.51")	30 (1.18")	M6	13 (0.51")	12 (0.47")	30 (1.18")	M6	13 (0.51")	G1/4

\*Only for Reversible rotation

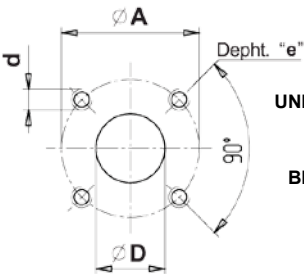

**code B**

Flanged ports  
german standard

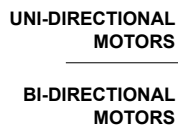

TYPE	OUTLET				INLET				DRAIN*
	Ø D	Ø A	d	e	Ø D	Ø A	d	e	DR
From 2.8 to 11	13 (0.51")	30 (1.18")	M6	13 (0.51")	12 (0.47")	30 (1.18")	M6	13 (0.51")	G1/4

\*Only for Reversible rotation

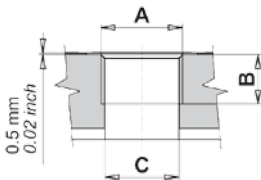

**code G**

Threaded ports  
GAS (BSPP)



TYPE	OUTLET			INLET		
	A	B	C	A	B	C
From 2.8 to 6.2	G1/2	15 (0.59")	17 (0.67")	G3/8	13 (0.51")	13 (0.51")
From 7.6 to 11				G1/2	15 (0.59")	

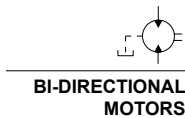

TYPE	OUTLET			INLET			DRAIN
	A	B	C	A	B	C	DR
From 2.8 to 6.2	G3/8	13 (0.51")	13 (0.51")	G3/8	13 (0.51")	13 (0.51")	G1/4
From 7.6 to 11	G1/2	15 (0.59")	30 (1.18")	G1/2	15 (0.59")		

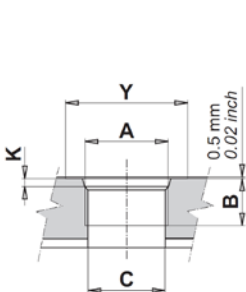

**code R**

Threaded ports  
SAE (ODT)



TYPE	OUTLET					INLET				
	A	B	C	Y	K	A	B	C	Y	K
From 2.8 to 6.2	3/4 - 16 UNF (SAE 8)	14.5 (0.57")	13 (0.51")	30 (1.18")	2.5 (0.10")	9/16 - 18 UNF (SAE6)	13 (0.51")	25 (0.98")	30 (1.18")	2.5 (0.10")
From 7.6 to 11	7/8 - 14 UNF (SAE10)	16.7 (0.66")	20 (0.79")	34 (1.34")	2.5 (0.10")	3/4 - 16 UNF (SAE8)	14.5 (0.57")	15 (0.59")		

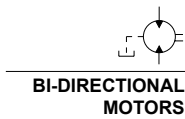

TYPE	OUTLET					INLET					DRAIN
	A	B	C	Y	K	A	B	C	Y	K	DR
From 2.8 to 6.2	3/4 - 16 UNF (SAE 8)	14.5 (0.57")	13 (0.51")	30 (1.18")	2.5 (0.10")	3/4 - 16 UNF (SAE8)	13 (0.51")	25 (0.98")	30 (1.18")	2.5 (0.10")	7/16 - 20 UNF (SAE4)
From 7.6 to 11	7/8 - 14 UNF (SAE10)	16.7 (0.66")	13 (0.51")	34 (1.34")	2.5 (0.10")	7/8 - 14 UNF (SAE10)	14.5 (0.57")	13 (0.51")			

EO.109.0417.02.00IM01



DRIVE SHAFTS

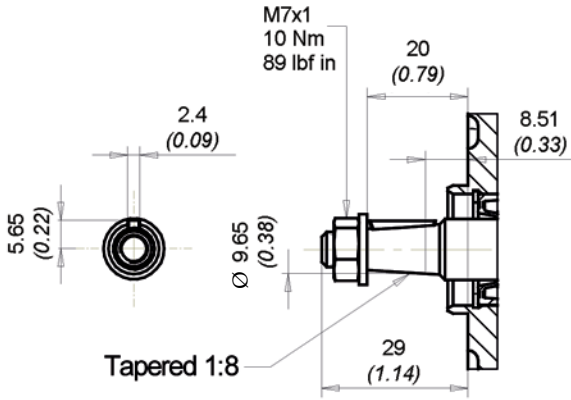

**code 18** Max torque 35 Nm (310 lbf in)  
European Tapered 1:8

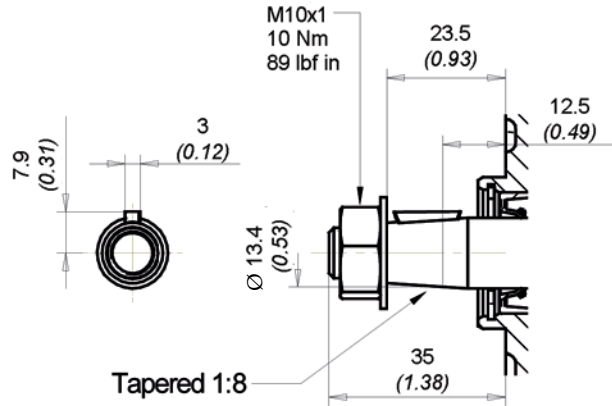

**code 19** Max torque 60 Nm (531 lbf in)  
European Tapered 1:8

Ext. Involute Spline ANSI B92.1  
with major diameter modified  
9 teeth - 20/40 Pitch - 30 deg  
Flat Root - Side fit - Class 5

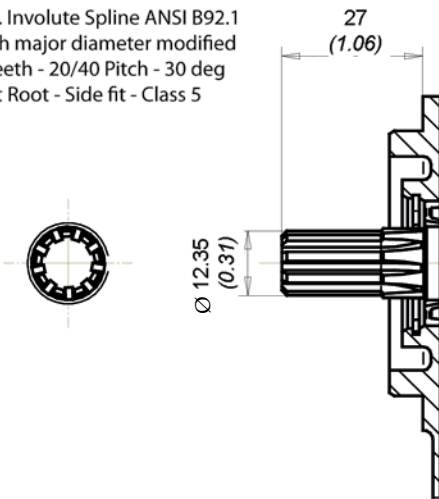

**code 51** Max torque 50 Nm (442 lbf in)  
SAE A Spline 9T

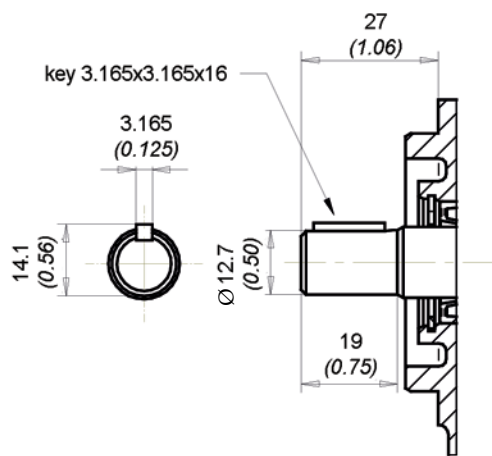

**code 80** Max torque 40 Nm (354 lbf in)  
SAE AA Parallel

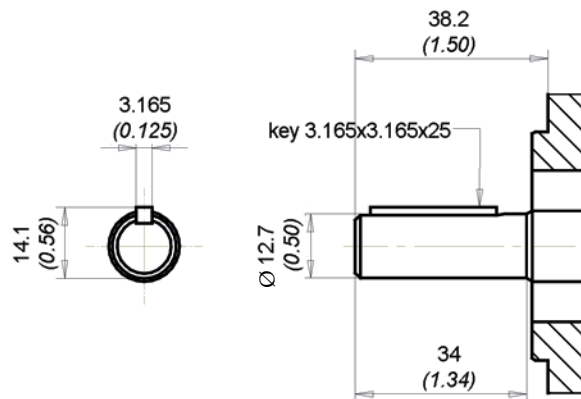

**code 83** Max torque 40 Nm (354 lbf in)  
SAE Parallel



**MOUNTING FLANGES**

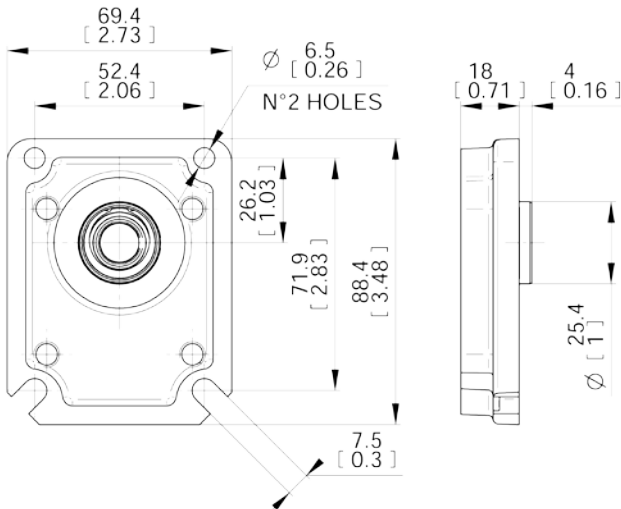

**P0** European standard  
With shaft code 18

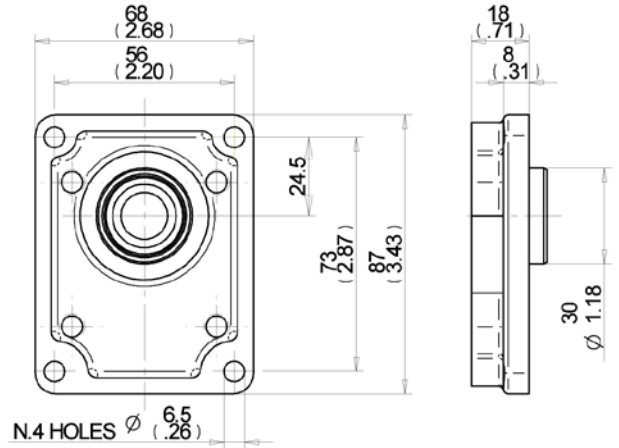

**P01** European standard  
With shaft code 19

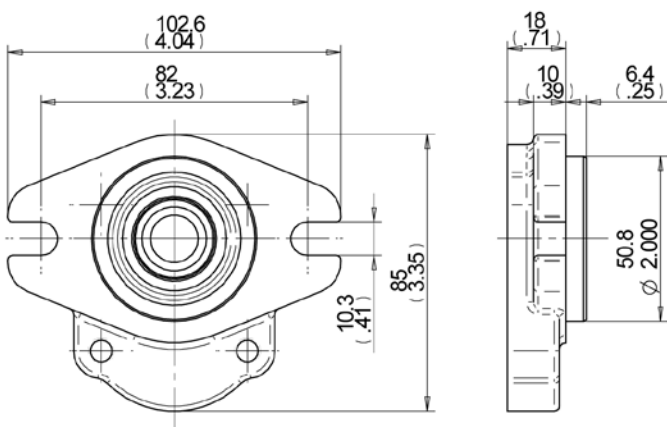

**S0** SAE AA 2 bolts  
With shaft code 51-80

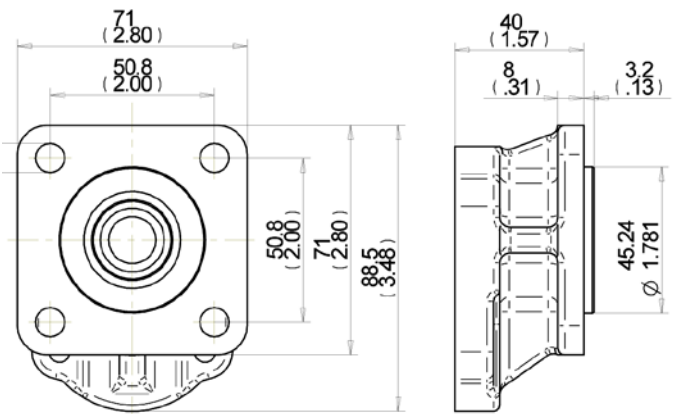

**S1** SAE AA 4 bolts  
With shaft code 83

EO.109.0417.02.00IM01



REAR COVERS WITH RELIEF VALVE

code VS

With main relief valve  
with internal unloading line.  
Rear cover with fixed setting main relief valve.  
Available values of fixed setting (20 bar-250 bar/290 psi-3625 psi)  
(Standard setting are multiple of 10 bar).

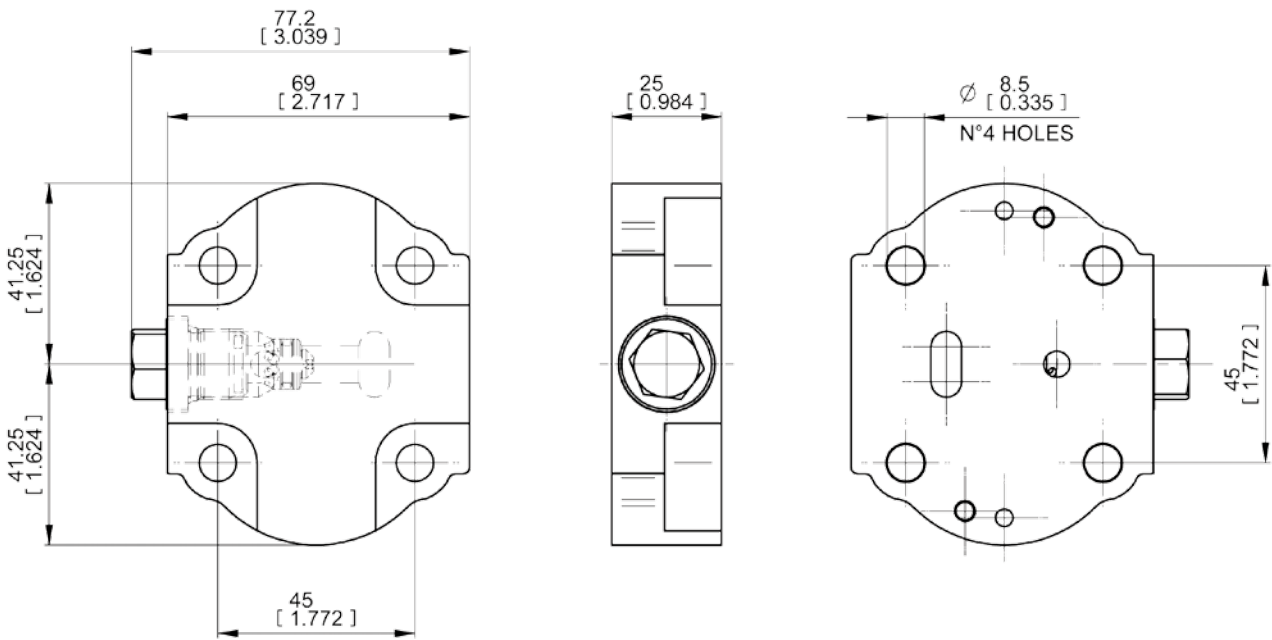
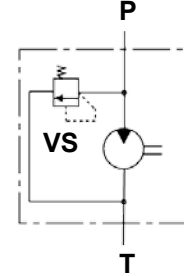

**PERFORMANCE CURVES**

Performance curves carried out with oil viscosity at 21 cSt and oil temperature at 50°C

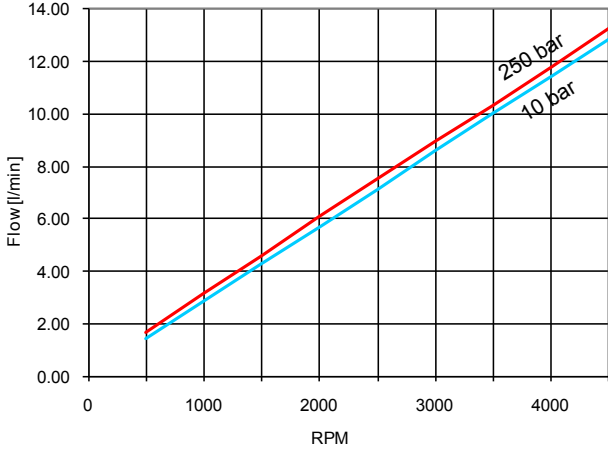

**1.5ME - 2.8**

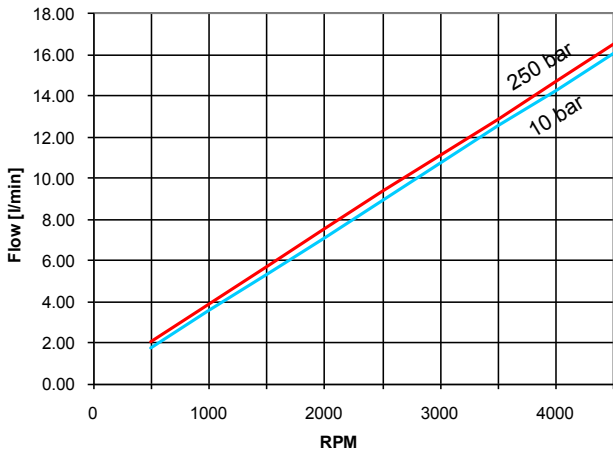
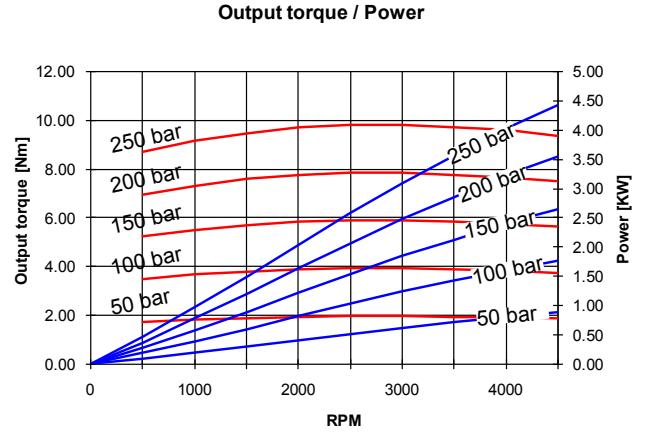

**1.5ME - 3.5**

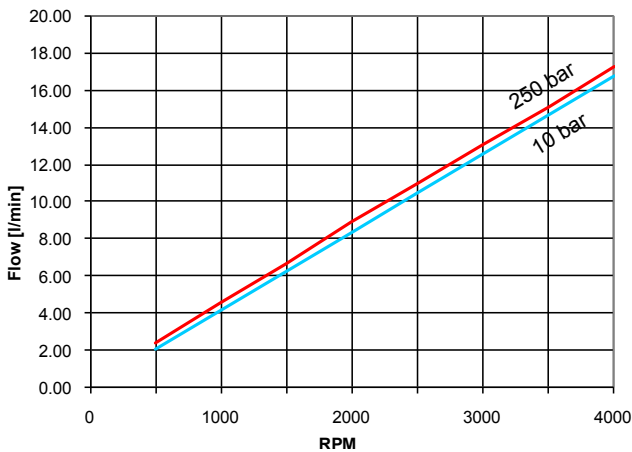
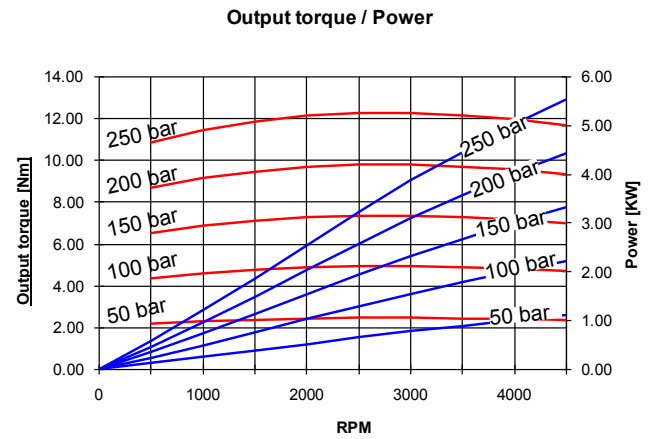

**1.5ME - 4.1**

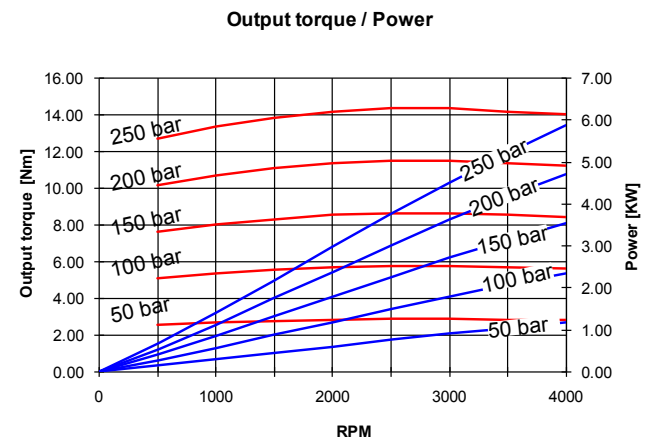

EO.109.0417.02.00IM01



## PERFORMANCE CURVES

Performance curves carried out with oil viscosity at 21 cSt and oil temperature at 50°C

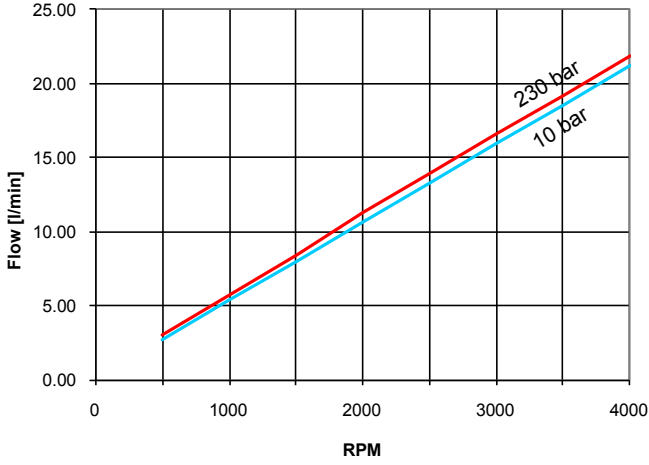

1.5ME - 5.2

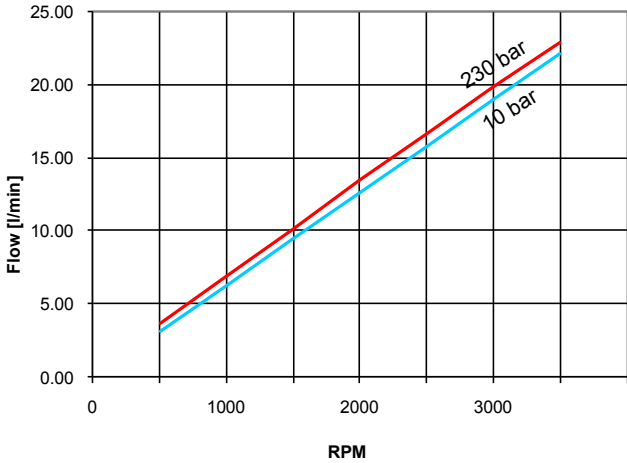
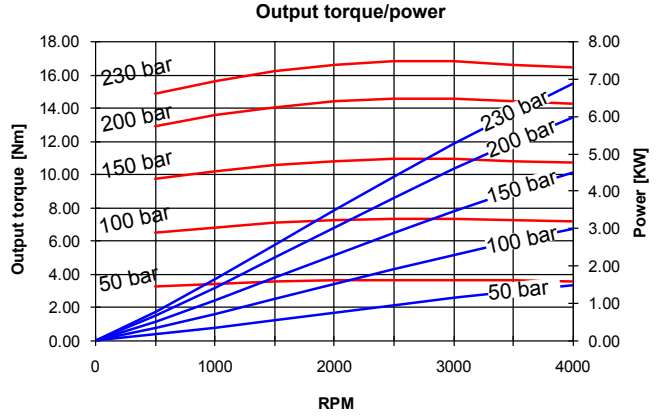

1.5ME - 6.2

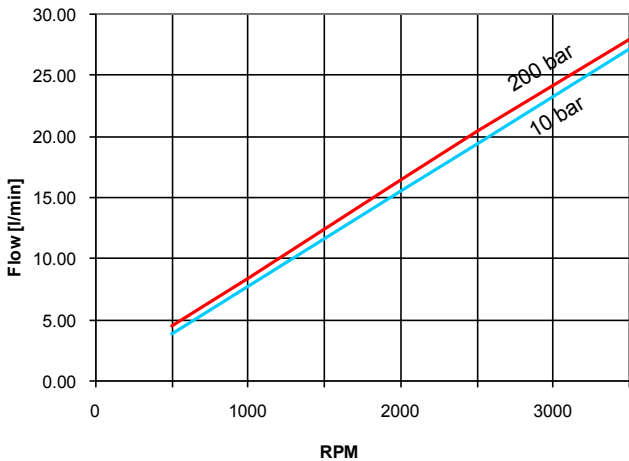
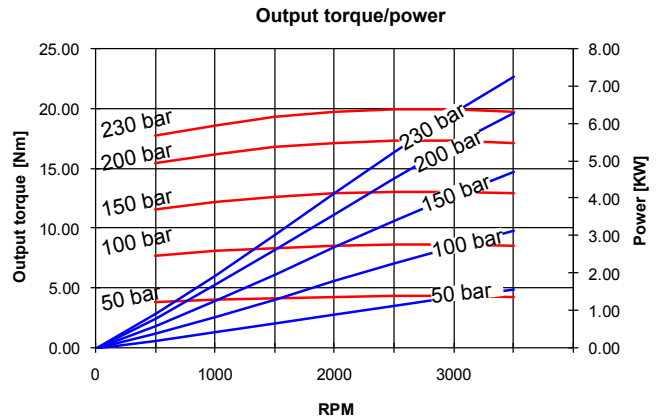

1.5ME - 7.6

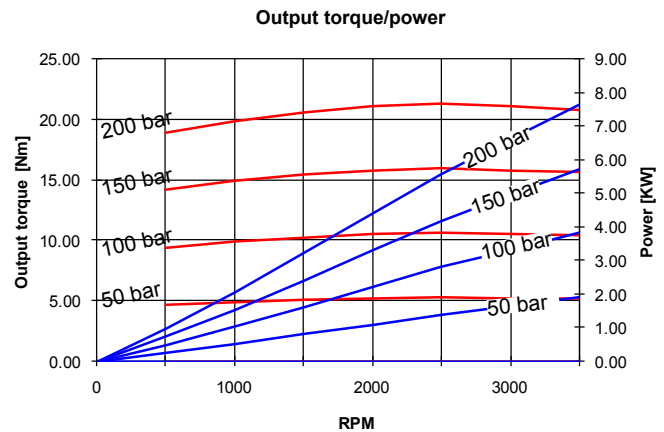

E0.109.0417.02.00IM01





**PERFORMANCE CURVES**

Performance curves carried out with oil viscosity at 21 cSt and oil temperature at 50°C

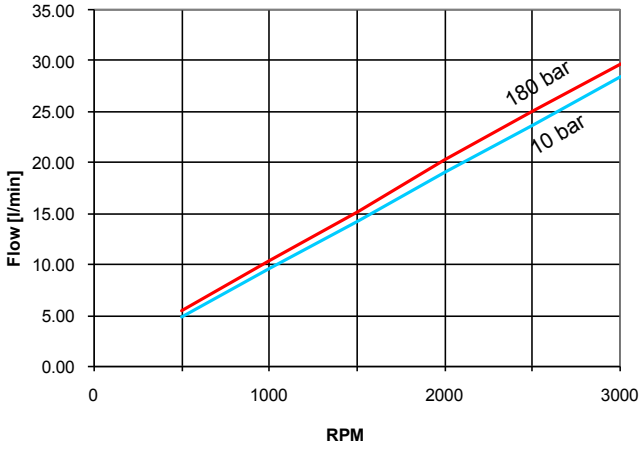

**1.5ME - 9.3**

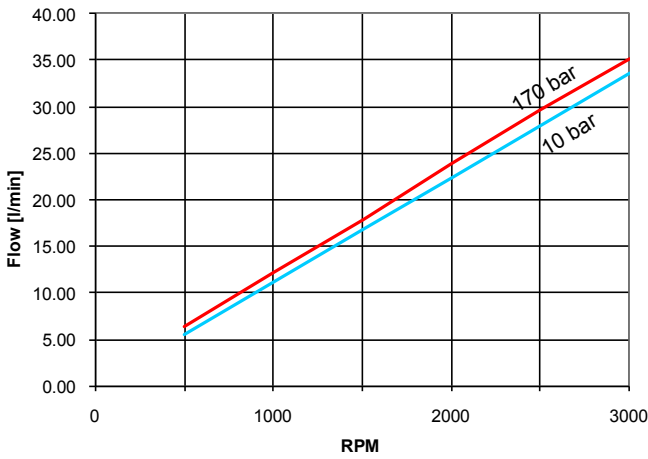
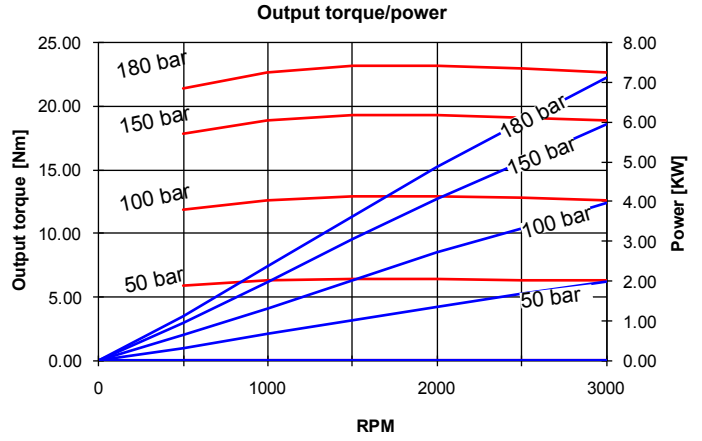

**1.5ME - 11**

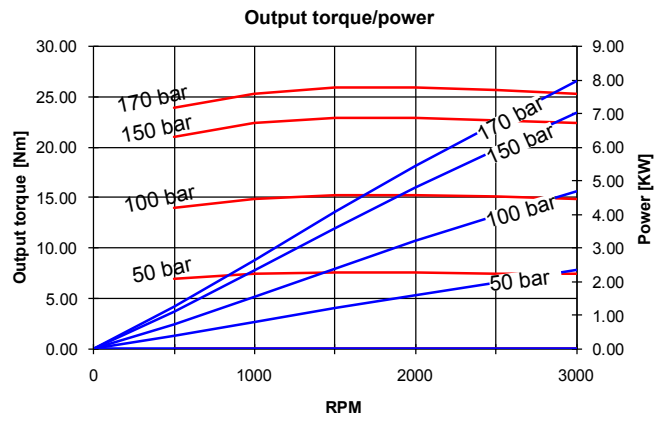

### SINGLE MOTORS

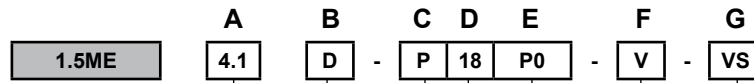

TYPE	DISPLACEMENTS		A
2.8	2.8 cm <sup>3</sup> /rev.	0.17 cu.in/rev.	
3.5	3.5 cm <sup>3</sup> /rev.	0.21 cu.in/rev.	
4.1	4.1 cm <sup>3</sup> /rev.	0.25 cu.in/rev.	
5.2	5.2 cm <sup>3</sup> /rev.	0.32 cu.in/rev.	
6.2	6.2 cm <sup>3</sup> /rev.	0.38 cu.in/rev.	
7.6	7.6 cm <sup>3</sup> /rev.	0.46 cu.in/rev.	
9.3	9.3 cm <sup>3</sup> /rev.	0.57 cu.in/rev.	
11	11 cm <sup>3</sup> /rev.	0.67 cu.in/rev.	

ROTATION (page 132)	CODES	B
Clockwise	D	
Anti-clockwise	S	
Reversible	R	

PORTS (page 141)	CODES	C
Flanged ports european standard	P	
Flanged ports german standard	B	
Threaded ports GAS (BSPP)	G	
Threaded ports SAE (ODT)	R	

DRIVE SHAFTS (page 142)	CODES	D
European Tapered 1:8	18	
European Tapered 1:8	19	
SAE A splined 9T	51	
SAE AA parallel Ø12,7	80	
SAE parallel Ø12,7	83	

G VALVES IN THE COVER (page 144)	CODE
Adjustable main relief valve	VS

F SEAL	CODE
Buna standard	
Viton	V

E MOUNTING FLANGES (page 143)	CODES
European standard	P0
European standard	P01
SAE AA (2 bolts)	S0
SAE AA (4 bolts)	S1

Order example 1.5ME11.3D, ports SAE (R), drive shaft (82),  
mounting flange (S2).  
**1.5ME11.3D-R82S2**



You can find our most up to date “STANDARD SALES CONDITIONS” on our website.

Potete trovare le nostre più aggiornate “CONDIZIONI DI VENDITA STANDARD”  
sul nostro sito.

**[www.salami.it](http://www.salami.it)**

T. +39 059 387 411

[sales@salami.it](mailto:sales@salami.it)

Watch our tutorials on youtube channel



Salami Fluid Power  
Salami Fluid Power World  
Salami Fluid Power France  
Salami Fluid Power España  
Salami Fluid Power Deutsch

**SALAMI S.P.A.**

Via Emilia Ovest 1006  
41121 Modena (Italy)  
T. +39 059 387 411  
F. +39 059 387 639  
sales@salami.it

**SALAMI ESPAÑA**

Poligono Industrial Armenteres  
C/Primer de Maig, 18, Nave 4  
08980 San Feliu de Llobregat  
Barcelona  
T. +34-93-6665451  
F. +34-93-6667826  
info@salamispain.com

**SALAMI FRANCE**

22, rue Louis Saillant  
69120 Valux en Velin  
Lyon  
T. +33-04-78809941  
F. +33-04-78803669  
e.pasian@salami.fr

**SALAMI HYDRAULICS N.A INC**

4630 Crossroads Park Drive  
Liverpool  
NY 13088 - USA  
T. +1-315-295-2363  
F. +1-315-295-2364  
info@salamihydraulics.com