

**EATON**

**Vickers**

**Servo-Performance Proportional  
Directional Valves with Feedback**

Pressures to 350 bar (5075 psi)

K(B)SDG4V-3  
1\* Series



# Contents

<b>Introduction</b>	
General Description	3
KSDG4V-3 Features and Benefits	3
KBSDG4V-3 Features and Benefits	3
Typical Section View	3
<b>Model Code</b>	4
<b>Spool Data</b>	5
<b>Functional Symbol</b>	5
<b>Operating Data</b>	6
<b>Pressures and Flow Rates</b>	7
<b>Performance Curves</b>	
Flow Gain	8
Pressure Gain	8
Power Capacity Envelopes	8
Frequency Response	9
<b>Installation Dimension KSDG4V-3</b>	10
<b>Installation Dimension KBSDG4V-3</b>	10
<b>Subplates and Mounting Surface Interfaces</b>	11
<b>Electrical Information</b>	
Block Diagram Voltage Input M1	13
Block Diagram Current Input M2	14
Typical Connection Arrangements M1	15
Typical Connection Arrangements M2	16
<b>Application Data</b>	
Fluid Cleanliness	17
Hydraulic Fluids	17
Installation	17
Mounting Bolt Kits	17
Seal Kits	17
Electrical Connectors	17
Service Information	17

# Introduction

## General Description

The KBSDG4V-3 line offers a range of proportional directional valves with integral control electronics. Factory-set adjustments of gain and offset ensure consistent reproducibility valve-to-valve.

These four-way solenoid operated proportional valves have a high dynamic performance which enables them to be used in closed-loop applications, previously possible only with servo valves. Various spool options are available for rated flows up to 40 L/min (10.6 USgpm). Working pressures are to 350 bar (5000 psi). The spool position is monitored by an LVDT which feeds back information to the amplifier, enabling spool position to be accurately maintained.

This valve type can be supplied with or without an integral amplifier built directly onto the valve.

## KSDG4V-3

Without the integral amplifier.

### Features and Benefits

- Wide range of spool and flow rate options.
- Supported by a broad range of amplifiers and auxiliary function modules.
- Electronic feedback LVDT ensures accurate spool position control.
- Internal current feedback provides optimal control.
- Vibration and shock tested.
- Full CE electromagnetic compatibility.

## KBSDG4V-3

With integral control electronics.

Factory-set adjustments of gain and offset ensure consistent repeatability valve-to-valve.

The only electrical inputs required are power supply (24V) and a command signal, either  $\pm 10V$  or 4-20 mA (model code selectable). The amplifier is housed in a robust metal enclosure, sealed against ingress of water and other fluids. Electrical connections are via a standard 7-pin plug.

A spool position monitor pin allows the function of the valve to be electrically monitored. Ramp functions, if required, can be generated externally.

### Features and Benefits

- Factory-sealed adjustments ensure valve-to-valve reproducibility.
- Installation wiring reduced and simplified.
- Standard 7-pin connector.
- Standard 24V DC supply with wide tolerance band.

- Optional command signal,  $\pm 10V$  or 4-20 mA (model code selectable).
- Valve with integrated amplifier selected, ordered, delivered and installed as one performance-tested package.
- Spool position monitor pin to help with troubleshooting.
- Simple valve removal and replacement for service (plug & play).
- Vibration and shock tested.
- Auxiliary DIN rail mounted electronic function modules available.
- Full CE electromagnetic compatibility.
- IP67 valve, environmental protection rating.
- Optional valve enable function.

## Typical Section View

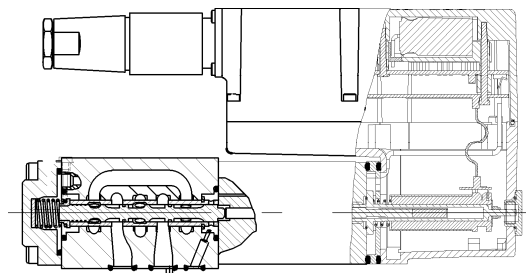

KBSDG4V-3

# Model Code

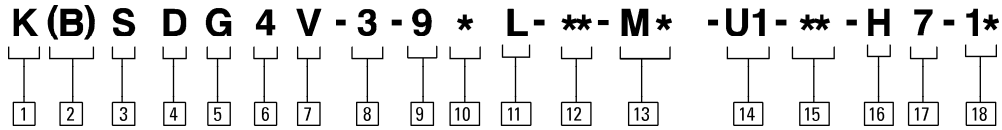

**1 Valve type**

**K** – Proportional valve

**2 Integral amplifier**

**B** – Integral amplifier “B” series

Omit for models without integrated amplifiers.

**3 Feed back arrangement**

**S** – Closed-loop

**4 Control type**

**D** – Directional valve

**5 Mounting**

**G** – Subplate mounted

**6 Operation**

**4** – Solenoid operated

**7 Pressure rating**

**V** – >250 bar (3625 psi) on ports P, A, & B

**8 Interface**

**3** – ISO 4401, size 03-02-0-94

ANSI/B93.7M-D03

**9 Spool type (center condition)**

**9** – Zero lap (biased underlap)

**10 Spool type, spring offset condition**

**2** – Ports P, A, & T blocked

**6** – Port P blocked, A & B to tank

**11 Valve build**

**L** – Standard build

**12 Rated flow at 70 bar (1000 psi) loop Δp pressure drop**

**05** – 5 L/min (1.3 USgpm)

**12** – 12 L/min (3.2 USgpm)

**24** – 24 L/min (6.3 USgpm)

**40** – 40 L/min (10.6 USgpm)

For actual maximum flow refer to Power capacity envelope curves, page 8.

**13 LVDT plug**

(omit for valves with integral amplifier)

**M1** – ±10V voltage command signal

**M2** – 4-20 mA current command signal

**14 Solenoid connector**

(omit for valves with integral amplifier)

**U1** – ISO 4400/DIN 43650, non-integral amplifier type only (mating plugs supplied)

**15 Electrical connection (KBS valves only)**

**PC7** – 7 pin connector without plug

**PE7** – 7 pin electrical plug with mating half

**PH7** – As PE7 but with pin “C” used for enable signal

**PR7** – As PC7 but with pin “C” used for enable signal

**16 Coil rating**

**H** – 24V DC amplifier supply

**17 Port T pressure limit code**

**7** – For all spools

**18 Design number**

1\* series. Subject to change



**WARNING**

Valves with integral amplifiers are supplied with or without the metal 7-pin plug. The Vickers™ plug, part no. 934939, must be

correctly fitted to ensure that the EMC rating and IP67 rating are achieved. The plug retaining nut must be tightened with a torque of 2-2,0 Nm (1.5-2.5 lbf ft) to effect a proper seal.

# Spool Data

## Spool Symbols

### Functional Symbol

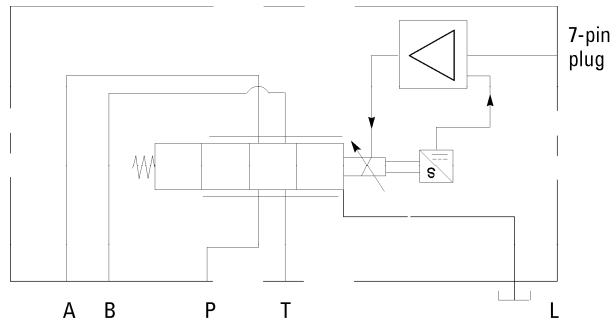

#### Model Types KBSDG4V-3

proportional directional valve (with integral electronics)

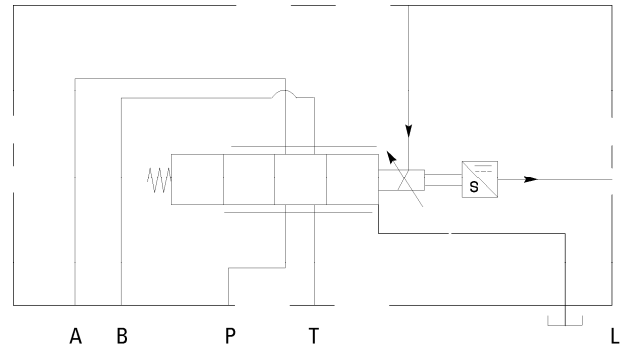

#### Model Types KSDG4V-3

proportional directional valve (requires amplifier card)

### Spool Types and Flow Ratings

#### Symmetric Spools

Base line starting at  $\Delta p = 35$  bar (500 psi) per metering flow path, e.g. B to T. For actual maximum flow refer to power capacity envelope curves.

Spool code	Spool symbol	Flow rating
For K(B)SDG4V-3 valves:		
92L05	92L	5 L/min (1.3 USgpm)
92L12	92L	12 L/min (3.2 USgpm)
92L24	92L	24 L/min (6.3 USgpm)
92L40	92L	40 L/min (10.6 USgpm)
96L05	96L	5 L/min (1.3 USgpm)
96L12	96L	12 L/min (3.2 USgpm)
96L24	96L	24 L/min (6.3 USgpm)
96L40	96L	40 L/min (10.6 USgpm)

### Available Spools for K(B)SDG4V-3

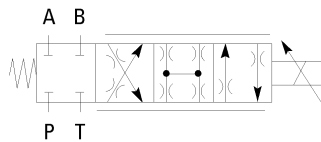

Spool type 92L

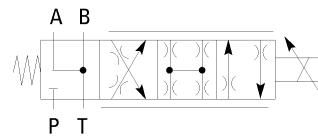

Spool type 96L

# Operating Data

**KBSDG4V-3 Valves with integral amplifier:** Data is typical, with fluid at 36 cSt (168 SUS) and 50°C (122°F).

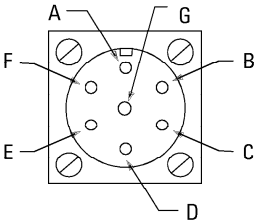
Power supply	24V DC (21V to 36V including 10% peak-to-peak max. ripple) max current 3A																		
Command signal	0 to 10V DC, or 0 to -10V DC, or -10V to + 10V DC																		
Voltage mode	M1: 47 kΩ - M2: 100R																		
Input impedance	18V (max)																		
Common mode voltage to pin D	4-20 mA																		
Current mode	100 mV																		
Max differential voltage to pin E to pin B																			
Valve enable signal for model code PH7																			
Enable	>8.5V (36V max)																		
Disable	<6.5V																		
Input impedance	10 kΩ																		
7-pin plug connector	<div style="display: flex; align-items: center;">  <table border="1" style="margin-left: 20px;"> <thead> <tr> <th>Pin</th> <th>Description</th> </tr> </thead> <tbody> <tr> <td>A</td> <td>Power supply positive (+)</td> </tr> <tr> <td>B</td> <td>Power supply 0V and current command return</td> </tr> <tr> <td>C</td> <td>Not connected (PE7 &amp; PC7)</td> </tr> <tr> <td>C</td> <td>Valve enable (PH7 &amp; PR7)</td> </tr> <tr> <td>D</td> <td>Command signal (+V or current in)</td> </tr> <tr> <td>E</td> <td>Command signal (-V or current GND)</td> </tr> <tr> <td>F</td> <td>Output monitor</td> </tr> <tr> <td>G</td> <td>Protective ground</td> </tr> </tbody> </table> </div>	Pin	Description	A	Power supply positive (+)	B	Power supply 0V and current command return	C	Not connected (PE7 & PC7)	C	Valve enable (PH7 & PR7)	D	Command signal (+V or current in)	E	Command signal (-V or current GND)	F	Output monitor	G	Protective ground
Pin	Description																		
A	Power supply positive (+)																		
B	Power supply 0V and current command return																		
C	Not connected (PE7 & PC7)																		
C	Valve enable (PH7 & PR7)																		
D	Command signal (+V or current in)																		
E	Command signal (-V or current GND)																		
F	Output monitor																		
G	Protective ground																		
View of pins of fixed half.																			
Electromagnetic compatibility (EMC):	IEC61326-2-1																		
Zero adjustment	±18% mechanical adjustment accessible under plug in LVDT																		
Monitor points signal																			
Voltage mode	±10V DC for full stroke																		
Output impedance	10 kΩ																		
Power stage PWM frequency	10 kHz nominal																		
Reproducibility, valve-to-valve (at factory settings):																			
Flow gain at 100% command signal	≤5%																		
Protection:																			
Electrical	Reverse polarity protected																		
Mechanical	IEC 144, Class IP67																		
Relative humidity	85 to 95% at 20 to 70°C (68 to 158°F)																		
Ambient air temperature range for full performance	0°C to 70°C (32°F to 158°F)																		
Oil temperature range for full performance	0°C to 70°C (32°F to 158°F)																		
Minimum temperature at which valves will work at reduced performance	-20°C (-4°F)																		
Storage temperature range	-25°C to +85°C (-13°F to +185°F)																		
Supporting products:																			
Auxiliary electronic modules (DIN-rail mounting):																			
EHA-CON-201-A2* signal converter	See catalog GB 2410A																		
EHD-DSG-201-A-1* command signal generator	See catalog GB 2470																		
EHA-RMP-201-A-2* ramp generator	See catalog GB 2410A																		
EHA-PID-201-A-2* PID controller	See catalog GB 2427																		
EHA-PSU-201-A-10 power supply	See catalog GB 2410A																		

# Operating Data

## KSDG4V-3 Valves without integral amplifier (requires a Eurocard amplifier, refer to Supporting Products)

Standing current at null	1,7A
Max current, at 50°C (122°F) ambient	3,2A
Coil resistance, at 20°C (68°F)	1,87Ω
Coil inductance, at 1000 Hz & 150 mV	7.2 mH
Max solenoid power	30W
LVDT supply voltage	+15V DC
LVDT output signal	4 to 20 mA for spool stroke of 2,1 mm
Electromagnetic compatibility (EMC)	IEC61326-2-1
Base amplifier	EAA-PAM-553-A-3* Power requirements: 20 to 40V DC at 40W
Mechanical protection	IEC 144, Class IP65
Maximum allowable ambient air temperature	60°C (140°F)
Maximum allowable oil temperature	60°C (140°F)

## KSDG4V-3 and KBSDG4V3 Valves (all valves)

Relative duty factor	Continuous rating (ED = 100%)
Hysteresis	<0.5%
Step response:	
Step size (% of max spool stroke):	Time to reach 90% of required step:
0-100% or 100-0%	10 mS
10-90% or 90-10%	6 mS
±10% to ±10%	4 mS
±25% to ±25%	5 mS
10-90%	6 mS
Mass:	
KSDG4V-3	2,09 kg (4.6 lb) approx.
KBSDG4V-3	2,49 kg (5.5 lb) approx.

## Pressures and Flow Rates

### Maximum pressures, bar (psi)

Port L condition	Ports P, A, B	T	L
Normally blocked by mounting surface	350 (5000)	50 (720)	50 (720)
Drained directly to tank	350 (5000)	210 (3000)	10 (145)

# Performance Curves

## Flow Gain

Flow from port P-A-B-T or P-B-A-T at 70 bar (1000 psi) total valve  $\Delta p$ , 35 bar (500 psi) per metering edge

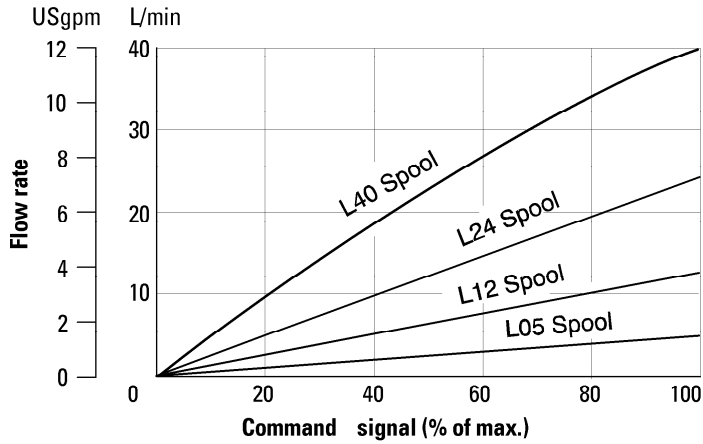

## Pressure Gain

$\Delta p$  between ports A and B or B and A, as % of port P pressure

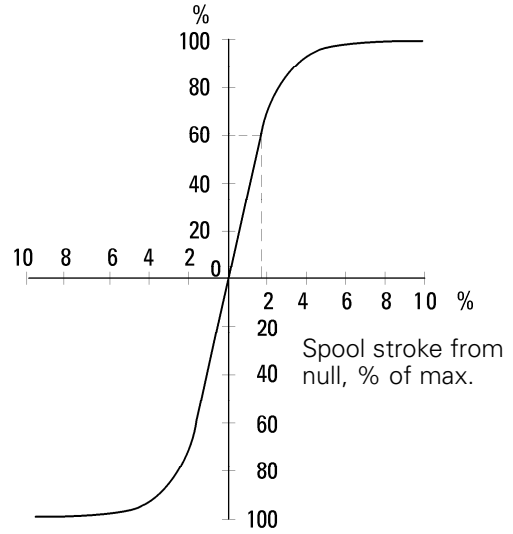

## Power Capacity Envelopes

### K(B)SDG4V-3-9\*L-05 Valves

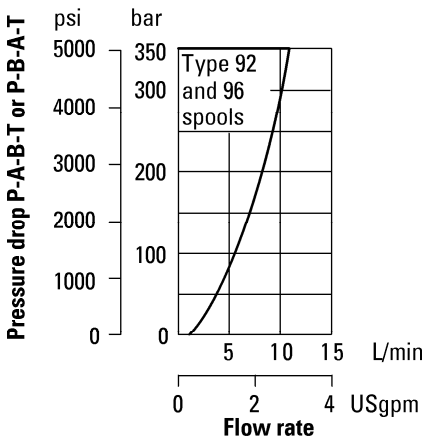

### K(B)SDG4V-3-9\*L-12 Valves

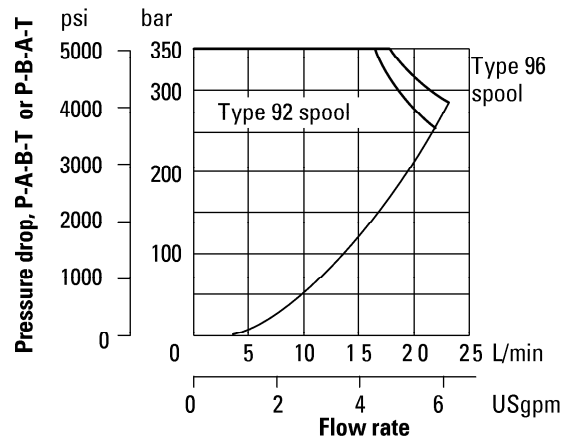



# Performance Curves

## Power Capacity Envelopes

K(B)SDG4V-3-9\*L-24 Valves

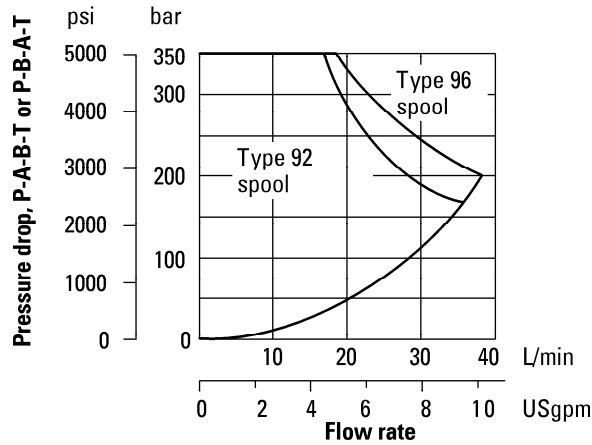

K(B)SDG4V-3-9\*L-40 Valves

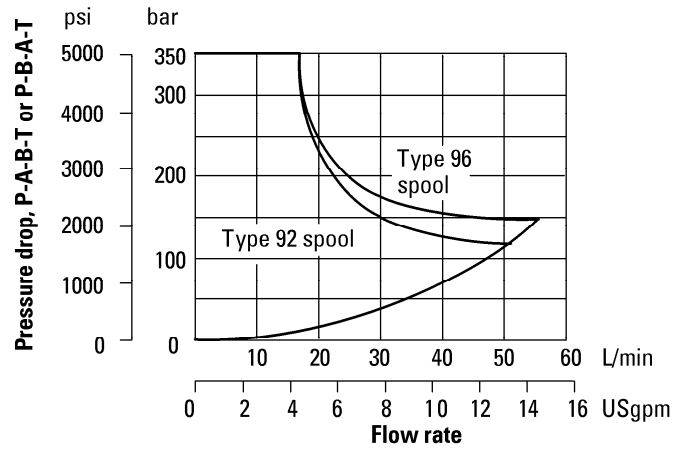

## Frequency Response, typical

For amplitudes of  $\pm 5\%$ ,  $\pm 10\%$ ,  $\pm 25\%$  with zero offset.  
 $\Delta p$  (P to T) = 70 bar (1000 psi)

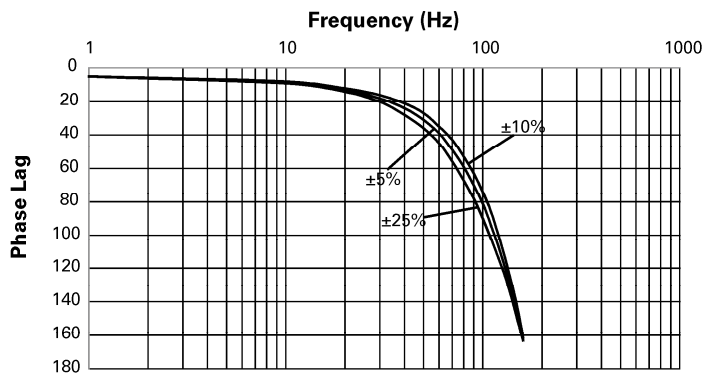

## Frequency Response

Looped flow at 70 bar valve pressure drop  
 Amplitudes based on % of rated flow

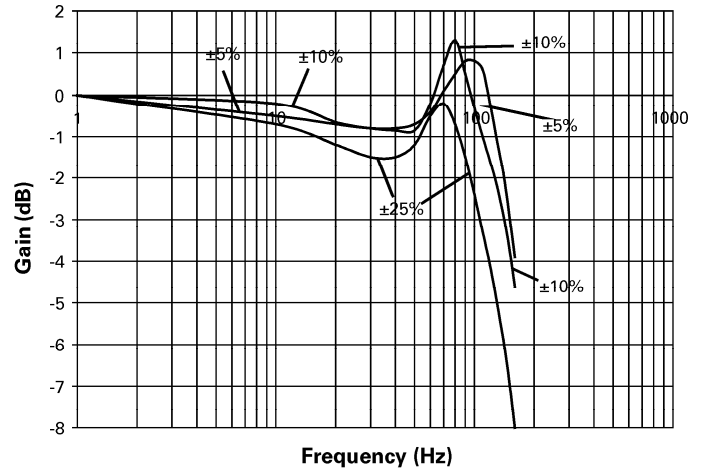

# Installation Dimensions

## KSDG4V-3

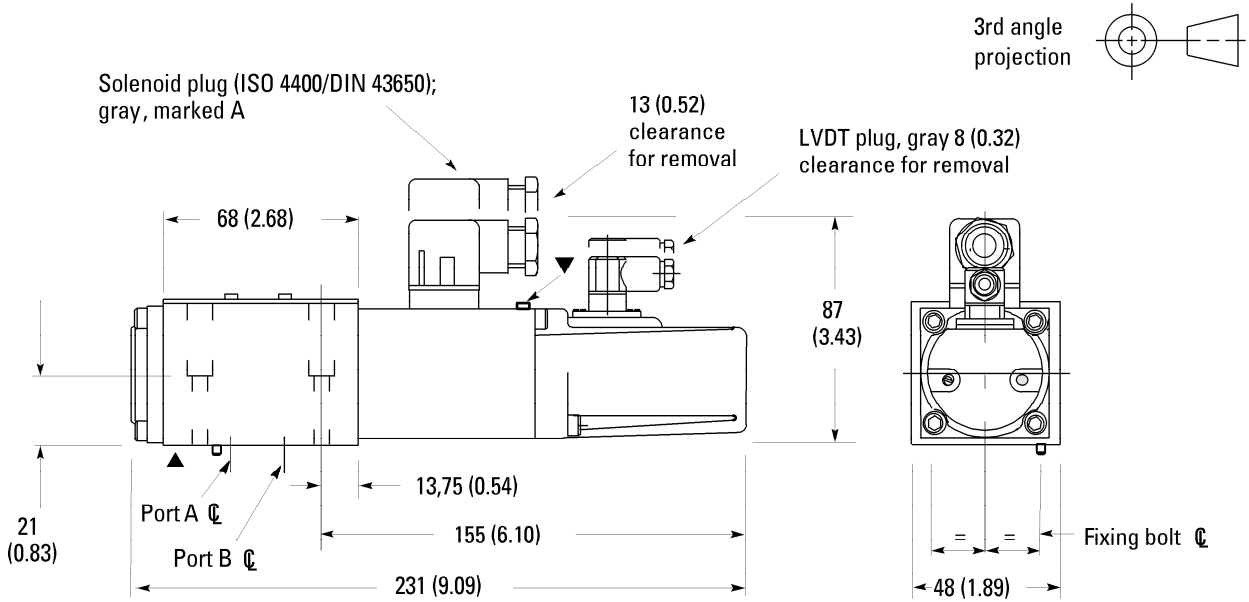

## KBSDG4V-3

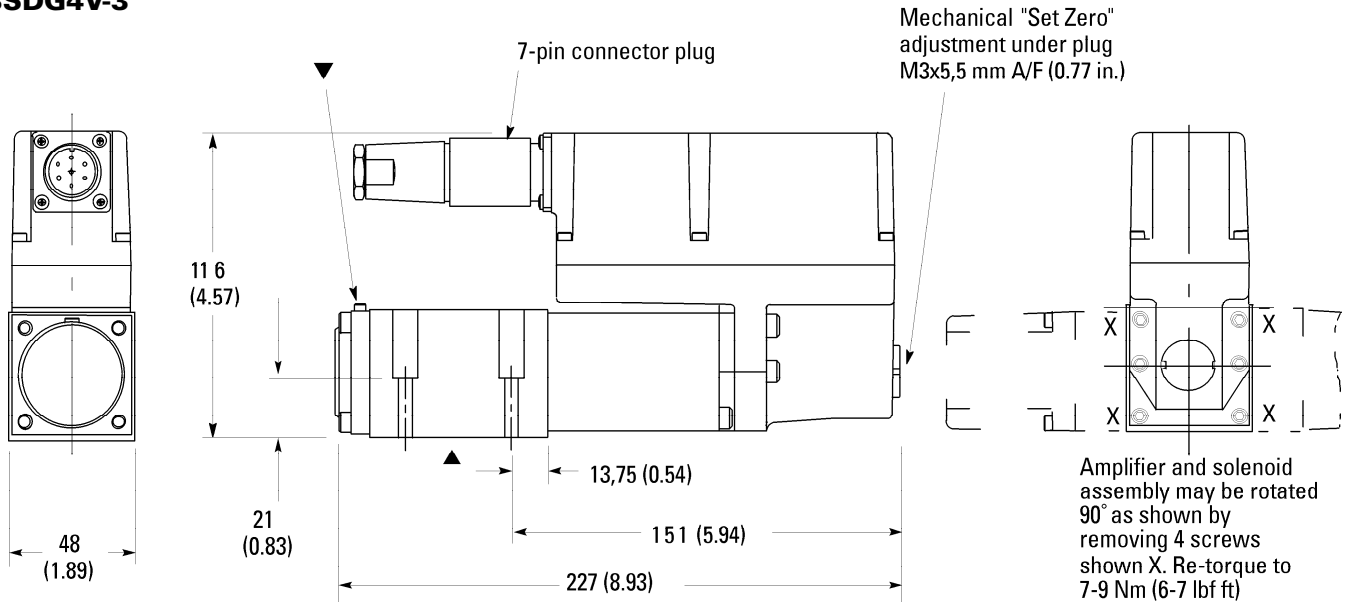

▲ Mounting surface seals supplied. For mounting surface dimensions and subplate options see page 11.

▼ Bleed screw location  
Air bleed, socket head cap screw  
Torque to 2,5-3,0 Nm (2.0-2.5 lbf ft)



### WARNING

Valves with integral amplifiers are supplied with or without the metal 7-pin plug. The Vickers™ plug, part no. 934939, must be

correctly fitted to ensure that the EMC rating and IP67 rating are achieved. The plug retaining nut must be tightened with a torque of 2-2,5 Nm (1.5-2.0 lbf ft) to effect a proper seal.

# Subplates and Mounting Surfaces

## General Description

If a subplate is not used, a machined pad must be provided for valve mounting. Pad must be flat within 0,0127 mm (.0005 inch) and smooth within 1,6 µm (63 microinch). Mounting bolts, when provided by customer, should be ISO 898 class 12.9 or better.

## Dimensional Tolerances

Dimensional tolerance on interface drawings is  $\pm 0,2$  mm ( $\pm 0.008$ " ) except where otherwise stated. ISO 4401 specifies inch conversion to  $\pm 0.01$ " .

## Conversion from Metric

ISO 4401 gives dimensions in mm. Inch conversions are accurate to 0.01" unless otherwise stated.

## Mounting Bolt Tappings

ISO 4401 gives metric thread tappings. Alternate UNC tappings are Eaton recommendations that allow

these plates and associated valves to be used up to their maximum pressures, when using Eaton recommended bolt kits, or bolts of an equivalent strength. It is recommended that Customer's own manifold blocks for UNC bolts should be tapped to the minimum depths given in the footnotes.

## Subplates

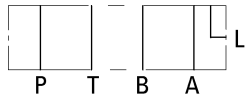
Description and Mass kg (lb)	Functional Symbol	Model Code	Max. Pressure
Single-station subplate; rear ports P, T, A, B; side port L Cast iron 1,3 (2.9)		KDGM-3-1*-R▲ KDGM-3-676803-1* (SAE/UNF ports)	250 bar (3600 psi)

\* Design number subject to change. No change of installation dimensions for design numbers 10 to 19 or 21 to 29 inclusive.

▲ "S" suffix = SAE/UNC ports and/or UNC fixing bolt tappings and/or orifice plugs as appropriate.

"R" or "B" = ISO 228 (BSPF) ports and/or metric fixing bolt tappings and/or orifice plugs as appropriate.

## Installation Dimensions

Single-Station Subplates,  
Rear and Side Tapped Ports

4 system connections for  
rear-entry models, see table

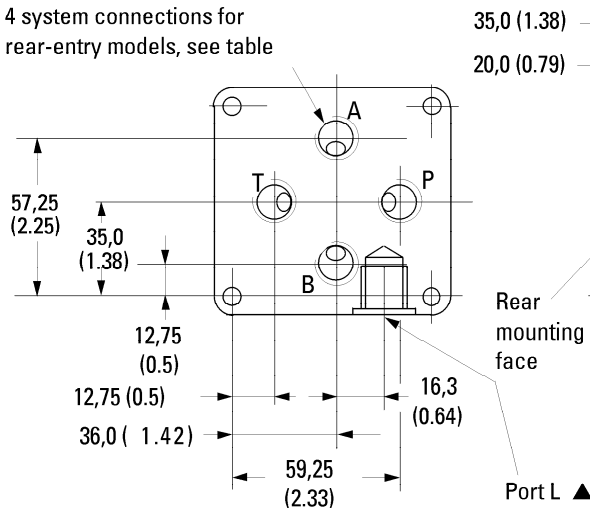

▲ 11,5 (0.45) from rear mounting face to port center line.

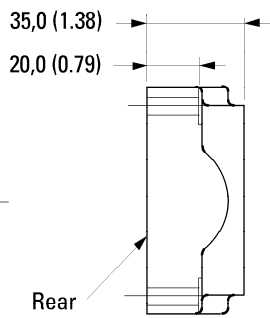

Rear mounting  
face

Port L ▲

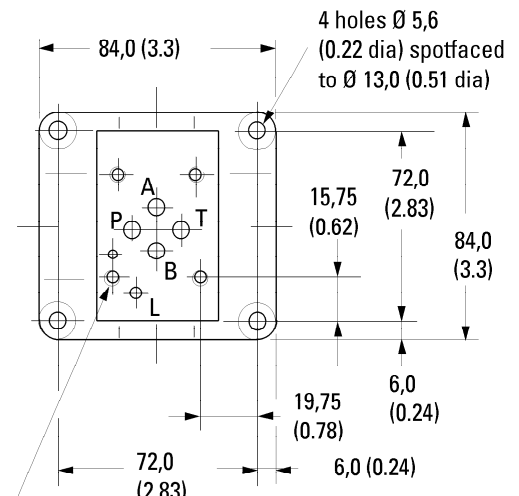
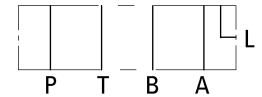

4 holes tapped according to model type (see table):  
For models with BSPF ports, M5 x 12 (0.47) deep  
For models with SAE ports, #10-24 UNC-2B x 12,7 (0.5) deep

Port Threads Model	Ports P, T, A, B, at rear or side	Port L
BSPF ports/M5 mounting bolts KDGM-3-1*-R	Rear G3/8 (3/8" BSPF) x 12,0 (0.47) deep	G1/8 (1/8" BSPF) x 12,0 (0.47) deep
SAE ports/#10-24 UNC mounting bolts: KDGM-3-676803-1*	Rear 3/4"-16 UNF-2Bx14,3 (0.56) deep (SAE)	7/16" -20 UNF-2B x 11,6 (0.46) deep (SAE)

# Mounting Surfaces

## Mounting Surfaces to ISO 401 (Size 03)

This interface conforms to:  
 ISO 4401-03-02-0-94  
 plus location pin hole  
 ANSI/B93.7M (and NFPA)  
 size 03  
 CETOP R35H4.2-4-03, plus  
 location pin hole  
 DIN 24340 Form A6 plus  
 location pin hole

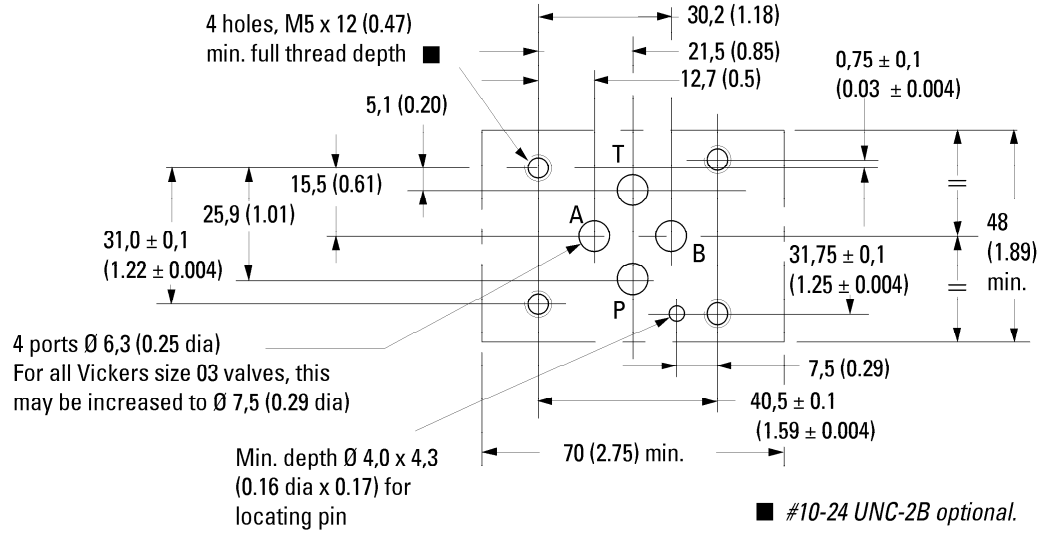

## Interface with Additional Drain Port

The interface conforms to  
 Eaton standard, plus hole  
 "L"

Typically used for  
 proportional and other valves  
 requiring an additional drain  
 port.

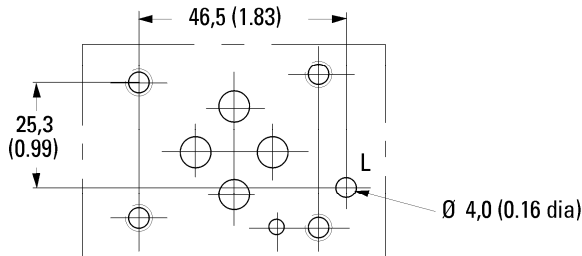

# Electrical Information

## Block Diagram Voltage Input (M1) KBSDG4V-3

### KBSDG4V-3 Wiring

Connections must be made via the 7-pin plug mounted on the amplifier. See page 15 of this leaflet and Eaton's Installation Wiring Practices for Vickers™ Electronic Products, leaflet 2468. Recommended cable sizes are:

#### Power cables:

For 24V supply

0,75 mm<sup>2</sup> (18 AWG) up to 20m (65 ft)

1,00 mm<sup>2</sup> (16 AWG) up to 40m (130 ft)

#### Signal cables:

0,50 mm<sup>2</sup> (20 AWG)

#### Screen (shield):

A suitable cable would have 7 cores, a separate screen for the signal wires and an overall screen.

Cable outside diameter 8,0–10,5 mm (0.31–0.41 inches)

See connection diagram on next page.

### KSDG4V-3 Wiring

Wiring details for these valves are contained in the appropriate Eurocard literature and Eaton's Installation Wiring Practices for Vickers™ Electronic Products leaflet 2468.

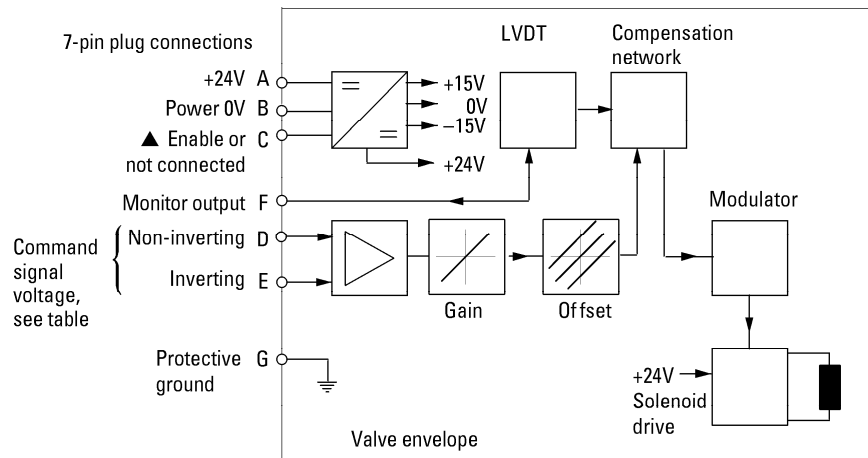

▲ Pin C is used for a valve enable signal with electrical connections PH7 and PR7.

#### Command Signals and Outputs, M1

7-pin plug		Flow direction
Pin D	Pin E	
Positive	0V	P to A
0V	Negative	
$U_D - U_E = \text{Positive}$		
Negative	0V	P to B
0V	Positive	
$U_D - U_E = \text{Negative}$		



#### WARNING

All power must be switched off before connecting/disconnecting any plugs.

# Electrical Information

## Block Diagram Current Input (M2) KBSDG4V-3

### KBSDG4V-3 Wiring

Connections must be made via the 7-pin plug mounted on the amplifier. See page 15 of this leaflet and Eaton's Installation Wiring Practices for Vickers™ Electronic Products, leaflet 2468. Recommended cable sizes are:

#### Power cables:

For 24V supply

0,75 mm<sup>2</sup> (18 AWG) up to 20m (65 ft)

1,00 mm<sup>2</sup> (16 AWG) up to 40m (130 ft)

#### Signal cables:

0,50 mm<sup>2</sup> (20 AWG)

#### Screen (shield):

A suitable cable would have 7 cores, a separate screen for the signal wires and an overall screen.

Cable outside diameter  
8,0–10,5 mm (0.31–0.41 inches)

See connection diagram on next page.

### KSDG4V-3 Wiring

Wiring details for these valves are contained in the appropriate Eurocard literature and Eaton's Installation Wiring Practices for Vickers™ Electronic Products leaflet 2468.

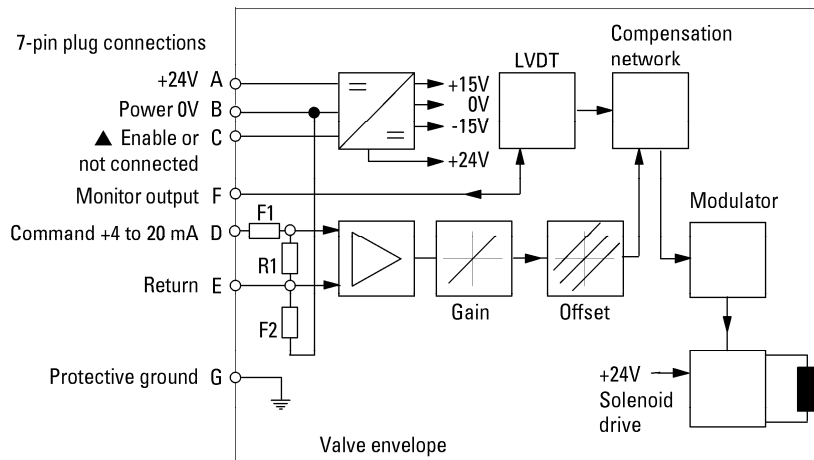

▲ Pin C is used for a valve enable signal with electrical connections PH7 and PR7.

R1 shunt resistor 100R

F1, F2 resettable fuse

### Command Signals and Outputs, M2

7-pin plug			
Pin D	Pin E	Pin B	Flow direction
More than 12 mA	Current return	Power ground	P to A
Less than 12 mA	Current return	Power ground	P to B



#### WARNING

All power must be switched off before connecting/disconnecting any plugs.

# Electrical Information

## Wiring Connections Voltage Input (M1)

■ Spool position monitor voltage (pin F) will be referenced to the KB valve local ground.



**WARNING**  
Do not ground pin C.

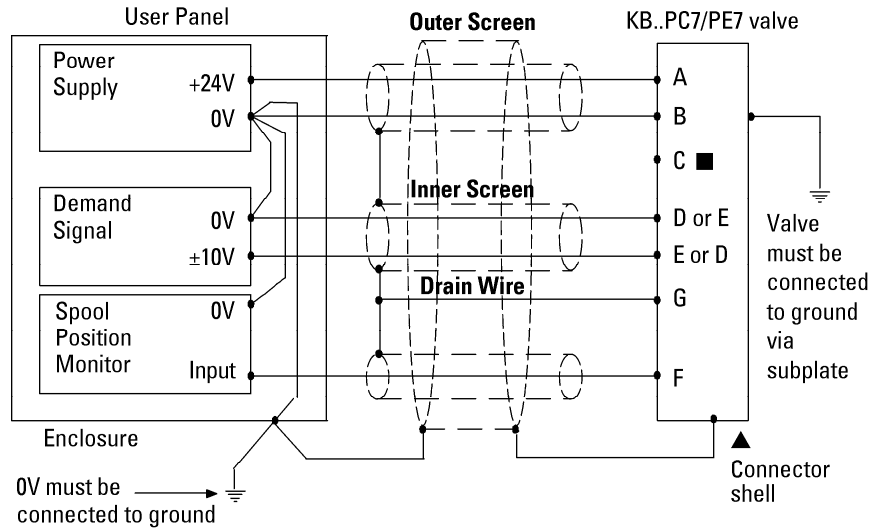

## Wiring Connections for M1 Valves with Enable Feature

▲ Note: In applications where the valve must conform to European RFI/EMC regulations, the outer screen (shield) must be connected to the outer shell of the 7 pin connector, and the valve body must be fastened to the earth ground. Proper earth grounding practices must be observed in this case, as any differences in command source and valve ground potentials will result in a screen (shield) ground loop.

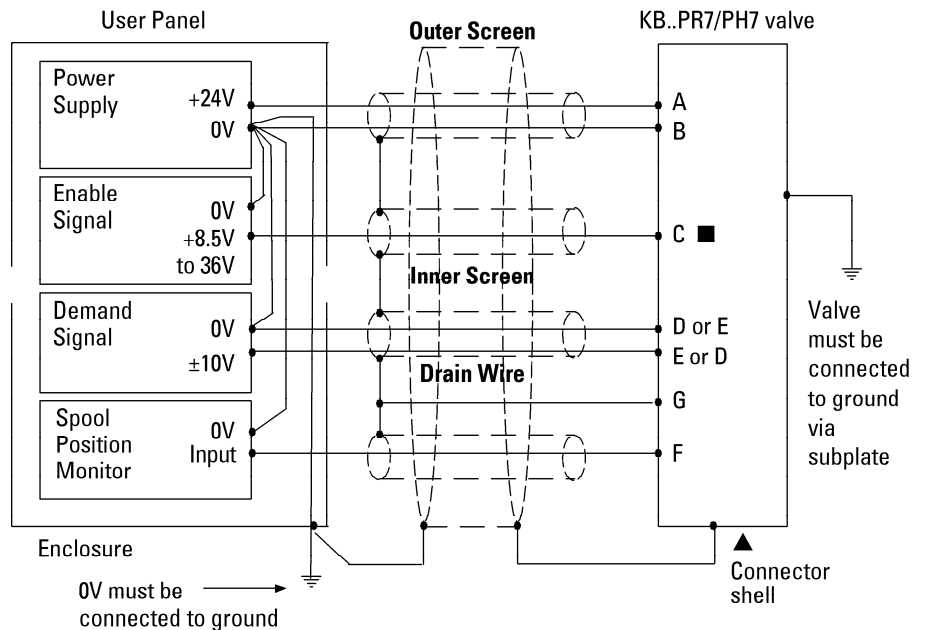

# Electrical Information

## Wiring Connections Current Input (M2)

■ Spool position monitor voltage (pin F) will be referenced to the KB valve local ground.



### WARNING

Do not ground pin C.

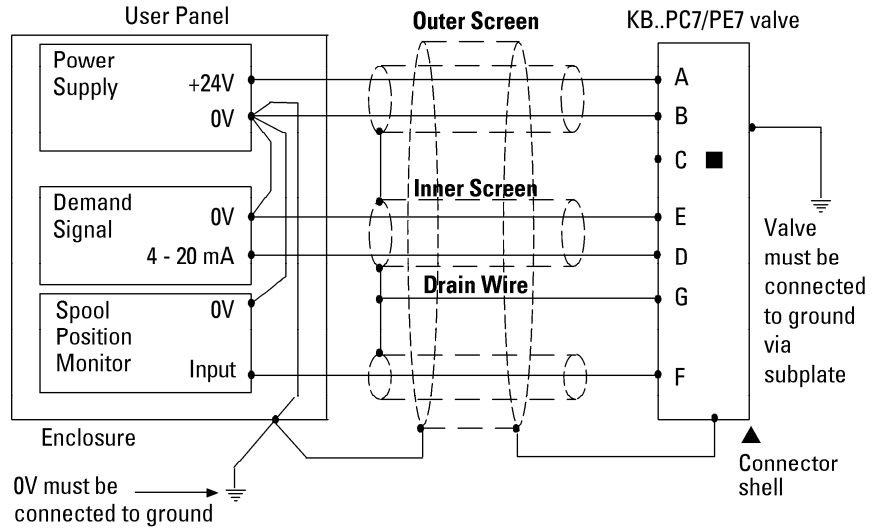

## Wiring Connections for M2 Valves with Enable Feature

▲ Note: In applications where the valve must conform to European RFI/EMC regulations, the outer screen (shield) must be connected to the outer shell of the 7 pin connector, and the valve body must be fastened to the earth ground. Proper earth grounding practices must be observed in this case, as any differences in command source and valve ground potentials will result in a screen (shield) ground loop.

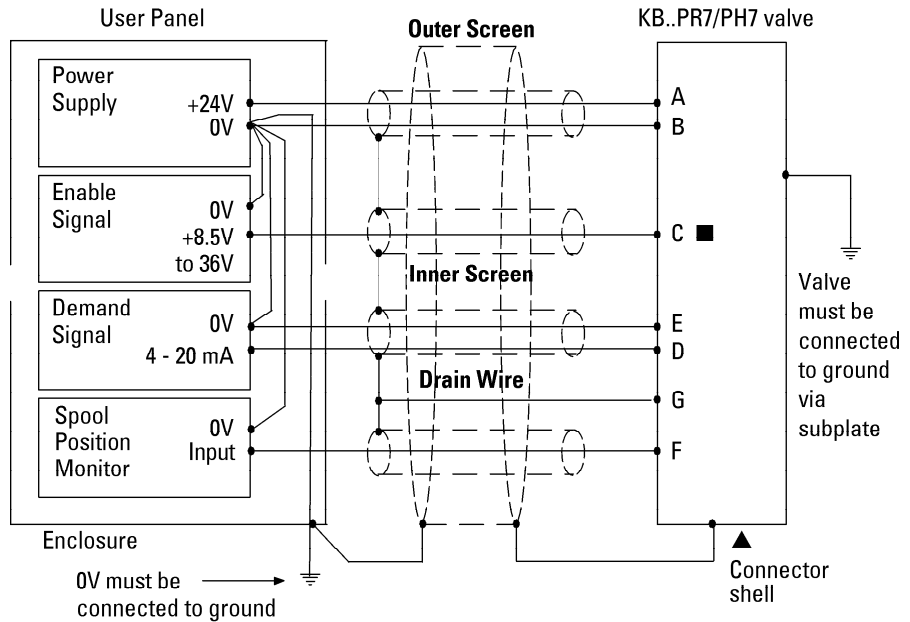

### WARNING

Electromagnetic Compatibility (EMC)

It is necessary to ensure that the valve is wired up as above. For effective protection the user electrical cabinet, the valve subplate or manifold and the cable

screens should be connected to efficient ground points. The metal 7 pin connector part no. 934939 should be used for the integral amplifier.

In all cases both valve and cable should be kept as far away as possible from any sources of electromagnetic

radiation such as cables carrying heavy current, relays and certain kinds of portable radio transmitters, etc. Difficult environments could mean that extra screening may be necessary to avoid the interference.

It is important to connect the 0V lines as shown above.

The multi-core cable should have at least two screens to separate the demand signal and monitor output from the power lines.

The enable line to pin C should be outside the screen which contains the demand signal cables.



# Application Data

## Fluid Cleanliness

Proper fluid condition is essential for long and satisfactory life of hydraulic components and systems. Hydraulic fluid must have the correct balance of cleanliness, materials and additives for protection against wear of components, elevated viscosity and inclusion of air.

Recommendations on contamination control methods and the selection of products to control fluid condition are included in Eaton's publication 9132 or 561, "Vickers™ Guide to Systemic Contamination Control." The book also includes information on the Eaton concept of "ProActive Maintenance". The following recommendations are based on ISO cleanliness levels at 2 µm, 5 µm and 15 µm.

For products in this catalog the recommended levels are:

0 to 70 bar (1000 psi):  
**18/16/13**

70+ bar (1000 + psi):  
**17/15/12**

Eaton products, as any components, will operate with apparent satisfaction in fluids with higher cleanliness codes than those described. Other manufacturers will often recommend levels above those specified.

Experience has shown, however, that life of any hydraulic components is shortened in fluids with higher cleanliness codes than those listed above. These codes have been proven to provide a long trouble-free service life for the products shown, regardless of the manufacturer.

## Hydraulic Fluids

Materials and seals used in these valves are compatible with antiwear hydraulic oils, and non-alkyl-based phosphate esters. The extreme operating viscosity range is 500 to 13 cSt (2270 to 70 SUS) but the recommended running range is 54 to 13 cSt (245 to 70 SUS).

## Installation

The proportional valves in this catalog can be mounted in any attitude, but it may be necessary in certain demanding applications, to ensure that the solenoids are kept full of hydraulic fluid. Good installation practice dictates that the tank port and any drain port are piped so as to keep the valves full of fluid once the system start-up has been completed.

## Mounting Bolt Kits

### For K(B)SDG4V-3

BK02-156493M (metric)

BK590716 (inch)

**If not using Eaton recommended bolt kits, bolts used should be to ISO 898, 12.9 or better.**

## Seal Kits

KSDG4V-3-1\* .....565108

KBSDG4V-3-1\* .....02-332693

## Electrical Connectors

KBSDG4V

7-pin plug (metal).....934939

7-pin plug (plastic).....694534

(metal plug must be used for full EMC protection)

KSDG4V

Solenoid (gray) .....710776

LVDT (gray) .....458939

## Service Information

The products from this range are preset at the factory for optimum performance; disassembling critical items would destroy these settings. It is therefore recommended that should any mechanical or electronic repair be necessary they should be returned to the nearest Eaton repair center. The products will be refurbished as necessary and retested to specification before return.

Field repair is restricted to the replacement of the seals.

Note:

The feedback/solenoid assembly installed in this valve should not be disassembled.

## Typical Part Numbers and Model Codes

5996404-001	KBSDG4V-3-92L-05-M1-PC7-H7-11	5996420-001	KBSDG4V-3-92L-40-M2-PE7-H7-11
5996398-001	KBSDG4V-3-92L-05-M1-PE7-H7-11	5996414-001	KBSDG4V-3-96L-05-M1-PC7-H7-11
5996399-001	KBSDG4V-3-92L-05-M1-PH7-H7-11	5996410-001	KBSDG4V-3-96L-05-M1-PE7-H7-11
5996405-001	KBSDG4V-3-92L-12-M1-PC7-H7-11	5996415-001	KBSDG4V-3-96L-12-M1-PE7-H7-11
5996400-001	KBSDG4V-3-92L-12-M1-PE7-H7-11	5996416-001	KBSDG4V-3-96L-12-M2-PE7-H7-11
5996401-001	KBSDG4V-3-92L-12-M1-PH7-H7-11	5996423-001	KBSDG4V-3-96L-12-M2-PE7-H7-11
5996406-001	KBSDG4V-3-92L-24-M1-PC7-H7-11	5996417-001	KBSDG4V-3-96L-24-M1-PC7-H7-11
5996402-001	KBSDG4V-3-92L-24-M1-PE7-H7-11	5996411-001	KBSDG4V-3-96L-24-M1-PE7-H7-11
5996407-001	KBSDG4V-3-92L-24-M1-PH7-H7-11	5996418-001	KBSDG4V-3-96L-40-M1-PC7-H7-11
5996421-001	KBSDG4V-3-92L-24-M2-PC7-H7-11	5996412-001	KBSDG4V-3-96L-40-M1-PE7-H7-11
5996408-001	KBSDG4V-3-92L-40-M1-PC7-H7-11	5996413-001	KBSDG4V-3-96L-40-M1-PH7-H7-11
5996403-001	KBSDG4V-3-92L-40-M1-PE7-H7-11	5996422-001	KBSDG4V-3-96L-40-M2-PE7-H7-11
5996409-001	KBSDG4V-3-92L-40-M1-PH7-H7-11		

**Eaton**  
Hydraulics Operations USA  
14615 Lone Oak Road  
Eden Prairie, MN 55344  
USA  
Tel: +1 952 937 9800  
Fax: +1 952 294 7722  
[www.hydraulics.eaton.com](http://www.hydraulics.eaton.com)

**Eaton**  
Hydraulics Operations Europe  
Route de la Longeraie 7  
1110 Morges  
Switzerland  
Tel: +41 21 811 4600  
Fax: +41 21 811 4601

**Eaton**  
Hydraulics Operations Asia Pacific  
11th Floor Hong Kong New World Tower  
300 Huaihai Zhong Road  
Shanghai 200021  
China  
Tel: +86 21 6387 9988  
Fax: +86 21 6335 3912



© 2007 Eaton Corporation  
All Rights Reserved  
Printed in USA  
Document No. V-VLPO-MC005-E  
Supersedes 5071.02/EN/0298/A  
August 2008