



# Char-Lynn

## Spool Valve Hydraulic Motors

Spool Valve motors incorporate the proven orbit motor principle to provide high torque at low speeds.



# Spool Valve Motors

## Highlights

### Product Description

Char-Lynn spool valve motors distribute pressurized fluid into and out of the Orbit gear set (Gerotor or Geroler) via valve slots integrated into the output shaft. The spool valve motors incorporate both valving and hydrodynamic journal bearings into a common shaft design. The valve section (spool valve) can be optimized for low flow, low speed needs using a low speed spool option to enhance smooth running performance.

These motors incorporate the proven orbit motor principle to provide high torque at low speeds.

Motor shaft rotation can be instantly reversed by changing direction of input/output flow while generating equal torque in either direction. The displacements available provide a wide variety of speeds and torques from any spool valve motor series.

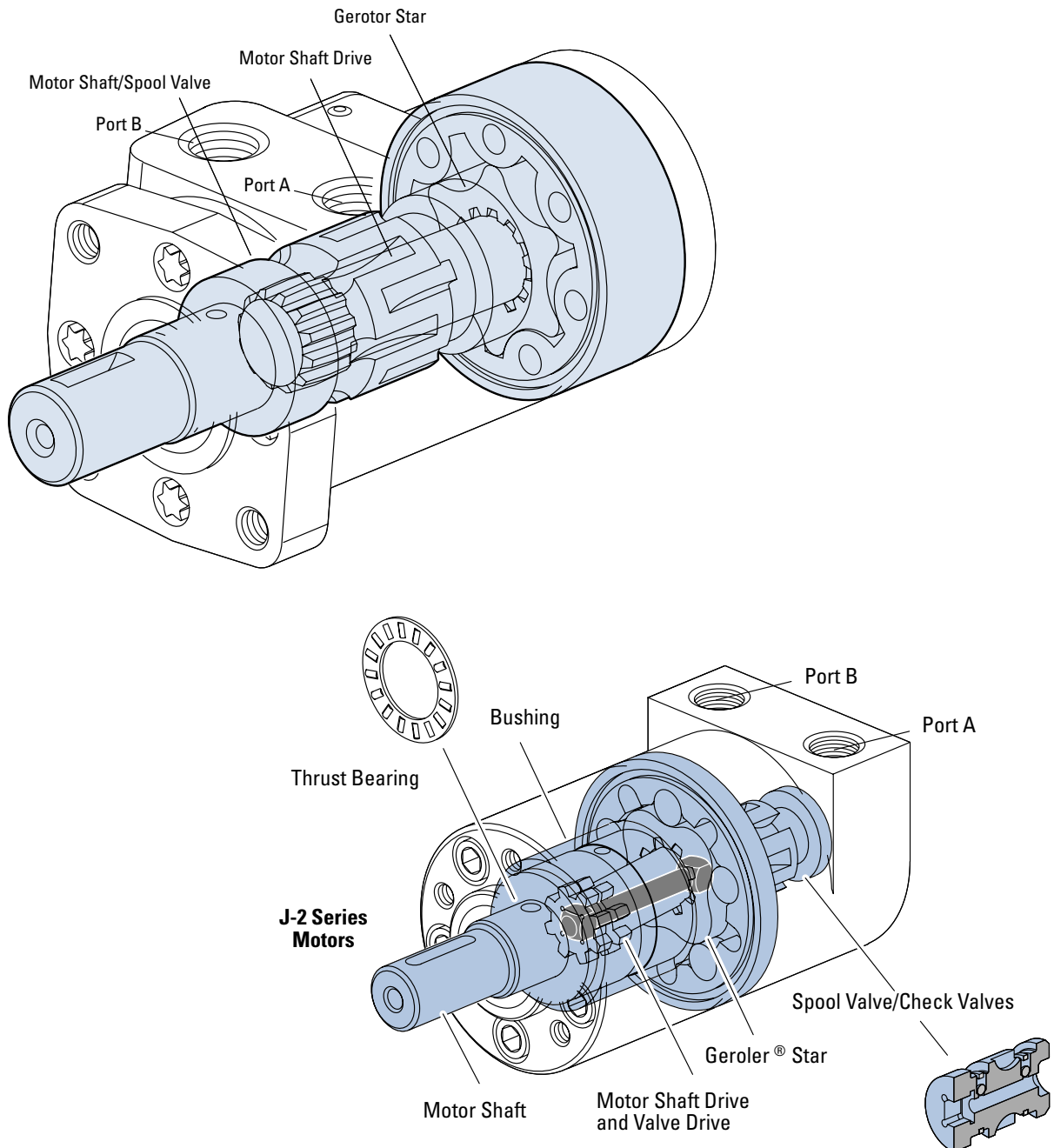

# Features, Benefits, and Applications

## Features

- Proven Orbit Motor Principle
- Hydrodynamic Journal Bearings
- Constant Clearance Geroler
- Three-Zone Pressure Design
- Reduced drive running-angle
- High-pressure seals
- Modular design

## Benefits

- Compact, powerful package
- Infinite bearing life (at rated loads)
- High efficiency
- Increases shaft seal & bearing life
- Smooth operation, increases drive life
- Reduces leakage
- Design flexibility
- Economically tailored solutions

## Applications

- Harvesters
- Augers
- Spreaders
- Machine tools
- Conveyors
- Winches
- Turf care equipment
- Food processing
- Aerial Work Platforms
- Anywhere a compact drive with high output torque is needed

## Design Features

Spool valve technology is typically used where compact, economical solutions are most needed. Spool valve motors use a spool valve to precisely time and control flow through the orbit gear set (Gerotor or Geroler). Inlet flow is directed into and out of the orbit set via slots in the spool and passages through the motor housing. The result is a very cost-effective compact package suited to many application requirements. The three

primary components in the motor are the orbit star, drive and output shaft. H, S and T Series incorporate the spool valve and hydrodynamic bearings in the motor shaft. The W series is similar except a ball bearing is used for the front bearing for increased side-load capacity. Due to its compact size and high speed capability, the J Series is unique and utilizes a separate dedicated spool and spool valve drive. All motors utilize Eaton's

constant-clearance Geroler technology except the H Series, which continues to use the time-proven H motor gerotor set. These motors all use a three-zone pressure design consisting of three unique pressure areas: 1) inlet, 2) return, 3) case. This provides the capability to limit motor case pressure and allows the use of several case pressure options for extended shaft seal and thrust bearing life.

Below is a quick-guide to help select the proper motor for your application:

### MOTOR QUICK-GUIDE (BASED ON MAXIMUM CONTINUOUS RATINGS)

Series	Output Torque Nm [lb-in]	Pressure bar [psi]	Flow lpm [gpm]	Side Load kg [lbs]
J Series	62 [550]	140 [2030]	21 [5.5]	196 [430]
H Series	407 [3607]	124 [1800]	57 [15]	635 [1400]
S Series	430 [3800]	135 [2000]	55 [15]	635 [1400]
T Series	450 [4000]	155 [2250]	55 [15]	635 [1400]
W Series	410 [3625]	165 [2400]	68 [18]	845 [1900]

\* The above are provided as guidelines only. Actual ratings vary depending on final motor configuration

# Table of Contents

Highlights	B-ii
Features, Benefits, and Applications	B-iii

## J Series (129-)

Highlights	B-1-1
Specifications	B-1-2
Performance Data	B-1-3
Dimensions	B-1-5
Product Numbers	B-1-9
Shaft Side Load Capacity	B-1-10
Case Pressure and Case Drain	B-1-11
Model Code	B-1-12

## H Series (101-)

Highlights	B-2-1
Specifications	B-2-2
Performance Data	B-2-3
Dimensions	B-2-9
Product Numbers	B-2-10
Model Code	B-2-11

## S Series (103-)

Highlights	B-3-1
Specifications	B-3-2
Performance Data	B-3-3
Dimensions	B-3-8
Product Numbers	B-3-9
S Series with Low Speed Valving	B-3-10
Model Code	B-3-11

## T Series (158-)

Highlights	B-4-1
Specifications	B-4-2
Performance Data	B-4-3
Dimensions	B-4-8
Product Numbers	B-4-9
Model Code	B-4-10

## T Series with Parking Brake (185-)

Highlights	B-4-11
Application Information	B-4-12
Specifications	B-4-13
Dimensions	B-4-14
Brake Release and Motor Case Pressure	B-4-15
Product Numbers	B-4-16
Model Code	B-4-17
<i>H, S and T Series (101-, 103-, 158-, 185-)</i>	
Side Load Capacity	B-4-18
Dimensions	B-4-19
Mounting Options	B-4-21

## W Series (162-)

Highlights	B-5-1
Specifications	B-5-2
Performance Data	B-5-3
Dimensions	B-5-5
Dimensions Shafts	B-5-6
Side Load Capacity	B-5-7
Model Code	B-5-8
<i>W Series with Parking Brake (162-)</i>	
Dimensions	B-5-9
Product Numbers	B-5-10
Model Code	B-5-11

# J Series (129-)

## Highlights

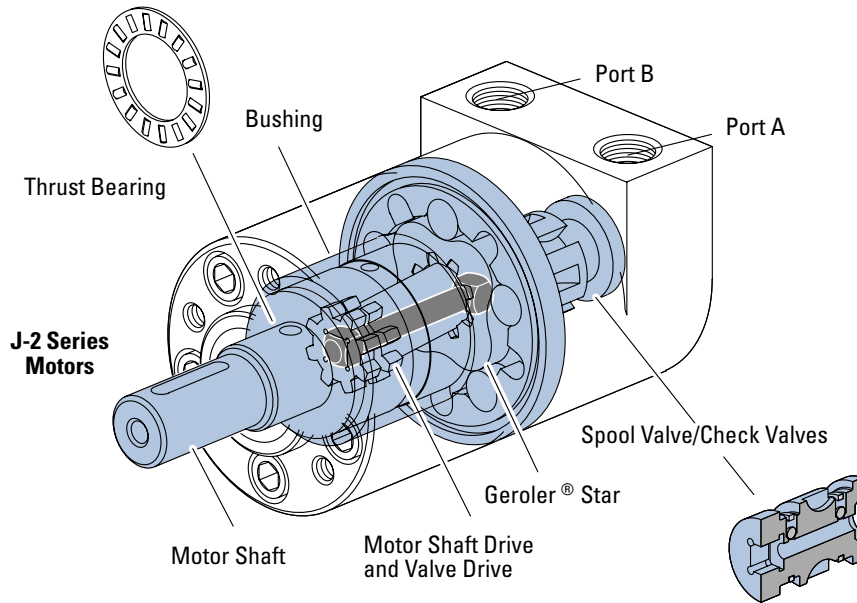

### Features:

- Constant clearance Geroler set
- Integrated check valves
- Self-lubricating shaft bushing
- High-strength rigid components
- Increased valve seal lands
- High pressure seals
- Variety of displacements, shafts, mounts and special options

### Benefits:

- High efficiency
- Extended leak-free performance
- Powerful compact package
- Design flexibility

### Applications:

- Agricultural augers, harvesters, seeders
- Car wash tire spray wands and brushes
- Marine bow thrusters
- Food processing
- Railroad maintenance equipment
- Machine tools
- Conveyors
- Snow blower chute rotator
- Industrial sweepers and floor polishers
- Saw mill works
- Turf equipment reel drives
- Paint stripper
- Many more

### Description

Char-Lynn J Series motors provide a lot of power from a very small package. Up to 5 kW [6 1/2 HP] of power. These motors are 61 mm [2.4 in] in diameter and 104 to 130 mm [4.1 to 5.1 in] in length.

The J Series motor shaft and seal allows high case pressure up to 76 bar [1100 PSI] return line pressure without case drain line. When a case drain line is used a 220 bar [3190 PSI] peak pressure is allowed in the return line.

### Specifications

Geroler Element	5 Displacements
Flow l/min [GPM]	21 [5.5] Continuous*** 25 [6.5] Intermittent**
Speed	Up to 1992 RPM Cont. Up to 2458 RPM Inter.
Pressure bar [PSI]	140 [2030] Cont.*** 165 [2400] Inter.**
Torque Nm [lb-in]	62 [549] Cont.*** 84 [743] Inter.**

\*\*\* Continuous—(Cont.) Continuous rating, motor may be run continuously at these ratings.

\*\* Intermittent—(Inter.) Intermittent operation, 10% of every minute.



Plastic Injection



Metal Forming



Food Processing



Ship-Boat Building

# J Series (129-)

## Specifications

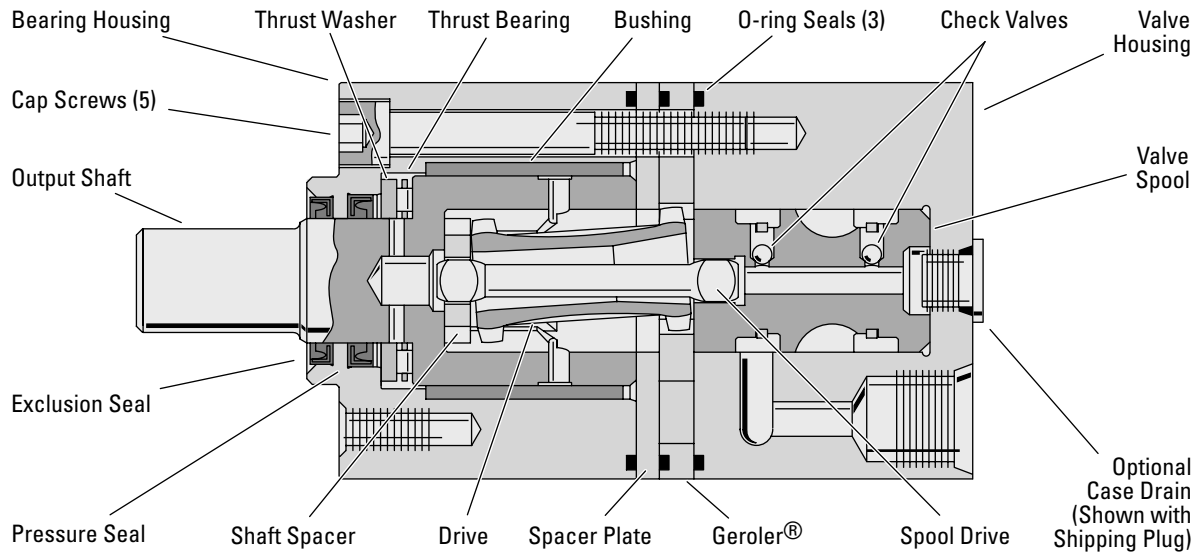

### SPECIFICATION DATA — J MOTORS

Displ. cm <sup>3</sup> /r [in <sup>3</sup> /r]		8,2 [50]	12,9 [79]	19,8 [1.21]	31,6 [1.93]	50,0 [3.00]
Max. Speed (RPM) @ Flow		1992	1575	1043	650	393
Flow l/min [GPM]	Continuous	17 [4.5]	21 [5.5]	21 [5.5]	21 [5.5]	21 [5.5]
	Intermittent	21 [5.5]	25 [6.5]	25 [6.5]	25 [6.5]	25 [6.5]
Torque Nm [lb-in]	Continuous	16 [141]	25 [225]	38 [333]	50 [446]	62 [549]
	Intermittent	19 [164]	30 [263]	46 [405]	62 [546]	84 [743]
	Peak	22 [193]	36 [321]	48 [425]	83 [733]	86 [765]
Pressure Δ bar [Δ PSI]	Continuous	140 [2030]	140 [2030]	140 [2030]	121 [1750]	97 [1400]
	Intermittent	165 [2400]	165 [2400]	165 [2400]	150 [2175]	140 [2030]
	Peak	220 [3190]	220 [3190]	220 [3190]	190 [2756]	150 [2175]
Weight kg [lbs]		2 [4.4]	2,1 [4.6]	2,2 [4.8]	2,3 [5.0]	2,4 [5.4]

\* Maximum pressure at motor inlet port is 220 Bar [3190 PSI] without regard to Δ bar [Δ PSI] and/or back pressure ratings or combination thereof.

#### Note:

To assure best motor life, run motor for approximately one hour at 30% of rated pressure before application to full load. Be sure motor is filled with fluid prior to any load applications.

#### Δ Pressure:

The true Δ bar [Δ PSI] difference between inlet port and outlet port.

See individual shafts for maximum torque recommendation. Splined shafts are recommended for those applications subject to frequent reversals.

#### Continuous Rating:

Motor may be run continuously at these ratings

#### Intermittent Operation:

10% of every minute

#### Peak Operation:

1% of every minute

#### Recommended Fluids:

Premium quality, anti-wear type hydraulic oil with a viscosity of not less than 70 SUS at operating temperature.

#### Recommended System Operating Temp.:

-34°C to 82°C  
[-30°F to 180°F]

#### Recommended Filtration:

per ISO Cleanliness Code 4406, level 20/18/13

# J Series (129-)

## Performance Data

Motors run with high efficiency in all areas designated with a number for torque and speed. For best motor life select a motor to run with a torque and speed range shown in the light shaded area.



Performance data is typical at 120 SUS. Actual data may vary slightly from motor to motor in production.

**8,2 cm<sup>3</sup>/r [0.50 in<sup>3</sup>/r]**

**Δ Pressure Bar [PSI]**  
Continuous

Max. Continuous  
Max. Intermittent

		[200]	[400]	[500]	[600]	[700]	[800]	[1000]	[1400]	[1500]	[2000]	[2030]	[2400]
		14	28	34	41	48	55	69	97	103	138	140	165
Flow LPM [GPM]	[1] 3.8	[11] 1 456	[25] 3 444	[33] 4 437	[40] 5 429	[47] 5 422	[55] 6 412	[69] 8 394	[96] 11 347	[102] 12 332	[130] 15 250	[132] 15 239	[146] 16 170
	[2] 7.6	[9] 1 897	[24] 3 886	[31] 4 877	[38] 4 867	[46] 5 860	[53] 6 847	[68] 8 823	[97] 11 768	[105] 12 749	[139] 16 657	[141] 16 647	[163] 18 557
	[3] 11.4	[6] 1 1349	[20] 2 1331	[28] 3 1318	[35] 4 1309	[44] 5 1296	[51] 6 1285	[65] 7 1261	[94] 11 1198	[102] 12 1176	[137] 15 1070	[139] 16 1060	[164] 19 959
	[4.25] 16.0		[16] 2 1902	[23] 3 1885	[30] 3 1873	[36] 4 1858	[44] 5 1846	[60] 7 1817	[90] 11 1750	[97] 11 1721	[133] 15 1599	[135] 15 1585	[160] 18 1475
	Max. Continuous 17.0	[4.5]	[16] 2 1992	[23] 3 1979	[29] 3 1964	[36] 4 1947	[43] 5 1929	[59] 7 1900	[89] 10 1833	[96] 11 1808	[131] 15 1684	[134] 15 1673	[160] 18 1553
Max. Intermittent 20.8	[5.5]		[12] 1 2458	[18] 2 2437	[26] 3 2420	[33] 4 2405	[40] 5 2387	[54] 6 2353	[83] 9 2272	[92] 10 2255	[124] 14 2134	[129] 15 2115	[154] 17 1994

 Continuous  
 Intermittent

**12,9 cm<sup>3</sup>/r [0.79 in<sup>3</sup>/r]**

**Δ Pressure Bar [PSI]**  
Continuous

Max. Continuous  
Max. Intermittent

		[200]	[400]	[500]	[600]	[700]	[800]	[1000]	[1400]	[1450]	[1500]	[2000]	2030	[2400]
		14	28	34	41	48	55	69	97	100	103	138	140	165
Flow LPM [GPM]	[1] 3.8	[19] 2 290	[43] 5 285	[54] 6 281	[65] 7 277	[76] 9 273	[88] 10 268	[109] 12 260	[154] 17 237	[159] 18 234	[164] 19 230	[214] 24 194	[217] 25 189	[250] 28 151
	[2] 7.6	[16] 2 573	[39] 4 566	[51] 6 561	[63] 7 555	[74] 8 549	[86] 10 544	[109] 12 534	[155] 18 501	[160] 19 496	[165] 20 490	[221] 25 442	[225] 25 437	[263] 30 396
	[3] 11.4	[11] 1 859	[35] 4 849	[47] 5 843	[58] 7 838	[70] 8 832	[82] 9 825	[105] 12 810	[152] 17 777	[157] 18 771	[163] 18 763	[219] 25 708	[223] 25 701	[263] 30 652
	[4] 15.1	[6] 1 1153	[30] 3 1140	[41] 5 1135	[53] 6 1129	[64] 7 1124	[76] 9 1117	[99] 11 1101	[146] 16 1060	[152] 17 1051	[157] 18 1044	[214] 24 982	[217] 25 975	[260] 29 924
	Max. Continuous 20.8	[5.5]	[19] 2 1575	[30] 3 1566	[42] 5 1556	[54] 6 1547	[65] 7 1539	[89] 10 1521	[136] 15 1473	[142] 16 1466	[148] 17 1457	[205] 23 1396	[209] 24 1387	[251] 28 1330
Max. Intermittent 24.6	[6.5]		[11] 1 1859	[23] 3 1851	[35] 4 1842	[46] 5 1831	[56] 6 1820	[81] 9 1804	[130] 15 1755	[135] 15 1743	[140] 16 1734	[198] 22 1670	[202] 23 1663	[243] 27 1599

[42] Torque [lb-in]  
5 }  
1556 } Speed RPM  
Nm

# J Series (129-)

## Performance Data

Motors run with high efficiency in all areas designated with a number for torque and speed. For best motor life select a motor to run with a torque and speed range shown in the light shaded area.

Performance data is typical at 120 SUS. Actual data may vary slightly from motor to motor in production.

### 19.8 cm<sup>3</sup>/r [1.21 in<sup>3</sup>/r]

Δ Pressure Bar [PSI]

Continuous

Max. Continuous

Max. Intermittent

		[200]	[400]	[500]	[600]	[700]	[800]	[1000]	[1400]	[1450]	[1500]	[2000]	[2030]	[2400]
		14	28	34	41	48	55	69	97	100	103	138	140	165
Flow LPM [GPM]	[1]	[32]	[67]	[85]	[102]	[119]	[136]	[170]	[236]	[244]	[253]	[321]	[325]	[374]
	3.8	4 189	8 187	10 186	12 185	13 183	15 182	19 179	27 172	28 170	29 169	36 141	37 138	42 114
	[2]	[30]	[65]	[83]	[101]	[119]	[136]	[172]	[223]	[248]	[257]	[328]	[333]	[388]
	7.6	3 379	7 375	9 373	11 370	13 368	15 366	19 361	25 351	28 349	29 347	37 312	38 309	44 285
[3]	[21]	[57]	[75]	[93]	[111]	[128]	[163]	[231]	[240]	[248]	[325]	[330]	[405]	
11.4	2 569	6 565	8 563	11 560	13 558	14 556	18 551	26 529	27 526	28 523	37 487	37 484	46 459	
[4]	[12]	[47]	[65]	[83]	[101]	[119]	[154]	[221]	[230]	[239]	[316]	[320]	[382]	
15.1	1 761	5 758	7 754	9 751	11 749	13 746	17 741	25 717	26 711	27 707	36 660	36 656	43 628	
Max. Continuous	[5.5]		[31]	[49]	[67]	[84]	[101]	[137]	[202]	[211]	[218]	[295]	[299]	[365]
20.8		4 1043	6 1040	8 1035	9 1033	11 1028	15 1021	23 997	24 993	25 990	33 938	34 934	41 899	
Max. Intermittent	[6.5]		[21]	[38]	[56]	[74]	[91]	[126]	[189]	[196]	[206]	[278]	[283]	[347]
24.6		2 1226	4 1222	6 1219	8 1215	10 1211	14 1204	21 1179	22 1174	23 1169	31 1121	32 1117	39 1079	

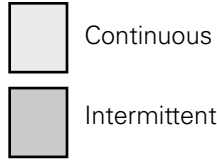

### 31.6 cm<sup>3</sup>/r [1.93 in<sup>3</sup>/r]

Δ Pressure Bar [PSI]

Continuous

Max. Continuous

Max. Intermittent

		[200]	[400]	[500]	[600]	[700]	[800]	[1000]	[1400]	[1450]	[1500]	[1750]	[2175]
		14	28	34	41	48	55	69	97	100	103	121	150
Flow LPM [GPM]	[1]	[51]	[106]	[133]	[160]	[187]	[213]	[265]	[362]	[372]	[383]	[439]	
	3.8	6 118	12 116	15 115	18 113	21 112	24 111	30 107	41 91	42 85	43 81	50 70	
	[2]	[46]	[103]	[132]	[159]	[187]	[214]	[269]	[362]	[374]	[387]	[446]	[546]
	7.6	5 236	12 234	15 232	18 230	21 228	24 225	30 221	41 187	42 179	44 175	50 165	62 145
[3]	[36]	[94]	[122]	[149]	[177]	[205]	[259]	[351]	[364]	[377]	[440]	[542]	
11.4	4 355	11 352	14 349	17 347	20 345	23 342	29 336	40 296	41 292	43 287	50 273	61 245	
[4]	[24]	[79]	[107]	[135]	[162]	[190]	[246]	[337]	[349]	[362]	[425]	[528]	
15.1	3 474	9 472	12 469	15 466	18 462	21 460	28 452	38 404	39 397	41 393	48 373	60 346	
Max. Continuous	[5.5]		[55]	[83]	[111]	[139]	[167]	[221]	[307]	[320]	[334]	[400]	[505]
20.8		6 650	9 647	13 645	16 640	19 636	25 629	35 584	36 580	38 575	45 550	45 513	
Max. Intermittent	[6.5]		[35]	[64]	[93]	[121]	[150]	[204]	[279]	[294]	[308]	[378]	[485]
24.6		4 767	7 764	11 760	14 755	17 751	23 742	32 712	33 707	35 701	43 675	43 637	

### 50.0 cm<sup>3</sup>/r [3.00 in<sup>3</sup>/r]

Δ Pressure Bar [PSI]

Continuous

Max. Continuous

Max. Intermittent

		[200]	[400]	[500]	[600]	[700]	[800]	[1000]	[1100]	[1200]	[1300]	[1400]	[2030]
		14	28	34	41	48	55	69	76	83	90	97	140
Flow LPM [GPM]	[1]	[82]	[167]	[211]									
	3.8	9 75	19 72	24 72									
	[2]	[70]	[156]	[201]	[243]	[286]	[327]						
	7.6	8 149	18 147	23 145	28 144	32 143	37 142						
[3]	[53]	[140]	[184]	[227]	[271]	[311]	[396]	[441]	[484]	[521]	[549]		
11.4	6 221	16 220	21 218	26 217	31 215	35 213	45 209	50 205	55 201	59 200	62 191		
[4]	[30]	[120]	[162]	[204]	[250]	[292]	[374]	[419]	[460]	[501]	[541]	[743]	
15.1	3 296	14 292	18 289	23 286	28 284	33 282	42 273	47 270	52 265	57 263	61 259	84 213	
Max. Continuous	[5.5]		[81]	[127]	[170]	[214]	[254]	[339]	[379]	[422]	[463]	[506]	[702]
20.8		9 393	14 392	19 389	24 387	29 383	38 377	43 372	48 369	52 364	57 358	79 302	
Max. Intermittent	[6.5]		[47]	[90]	[133]	[176]	[219]	[307]	[345]	[385]	[429]	[467]	[685]
24.6		5 465	10 462	15 460	20 458	25 455	35 448	39 445	43 440	48 435	53 430	77 364	

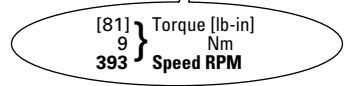



# J Series (129-)

## Dimensions

### Standard Rotation Viewed from Shaft End

Port A Pressurized — CW

Port B Pressurized — CCW

### 9/16 Inch End Port

9/16 -18 UNF - 2B O-ring Ports, M14 x 1,5  
 - 6H O-ring Ports — Metric Motor or  
 G 1/4 (BSP) Ports (2 ports each)

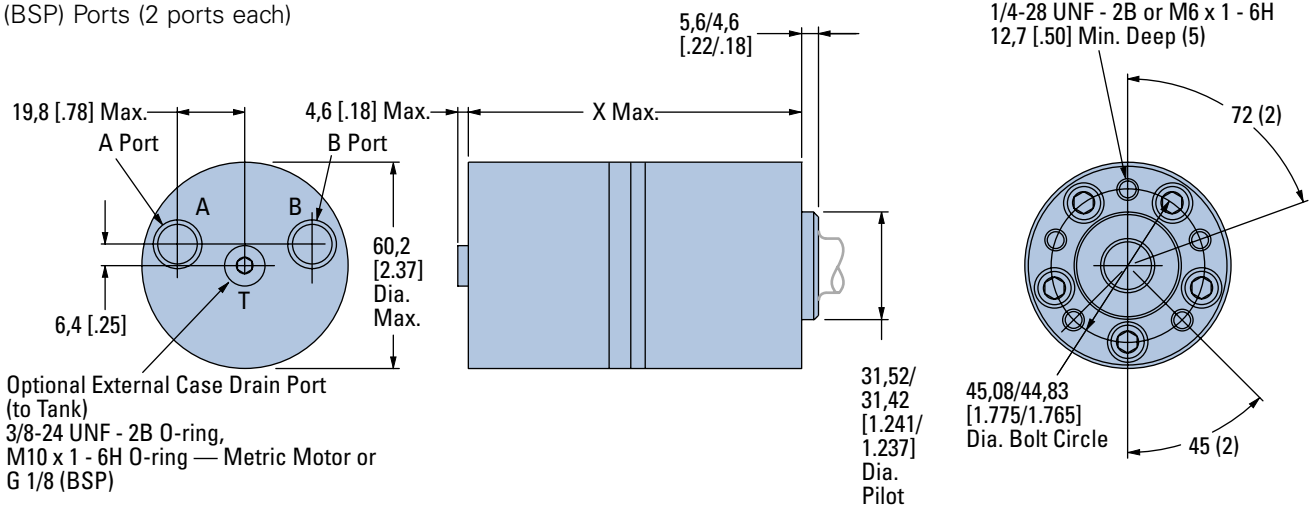

#### END PORT DIMENSIONS

Displacement cm <sup>3</sup> /r [in <sup>3</sup> /r]	X mm [inch]
8,2 [.50]	103,9 [4.09]
12,9 [.79]	106,9 [4.21]
19,8 [1.21]	112,5 [4.38]
31,6 [1.93]	118,9 [4.68]
50,0 [3.00]	130,3 [5.13]

### 3/8 Inch End Port

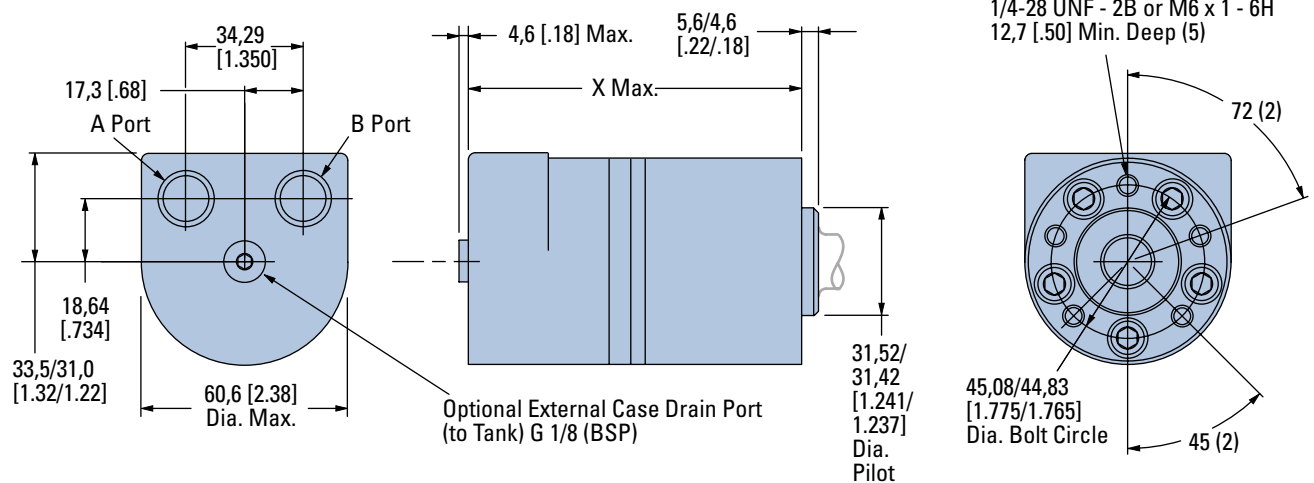

#### END PORT DIMENSIONS

Displacement cm <sup>3</sup> /r [in <sup>3</sup> /r]	X mm [inch]
8,2 [.50]	103,9 [4.09]
12,9 [.79]	106,9 [4.21]
19,8 [1.21]	112,5 [4.38]
31,6 [1.93]	118,9 [4.68]
50,0 [3.00]	130,0 [5.12]
160,5 [6.32]	132,3 [5.21]

# J Series (129-)

## Dimensions

### Ports

9/16 -18 UNF - 2B O-ring Ports,  
 M14 x 1,5 -6H O-ring Ports — Metric Motor,  
 G 3/8 or G 1/4 (BSP) Ports (2)

### Standard Rotation Viewed from Shaft End

Port A Pressurized — CW  
 Port B Pressurized — CCW

### Side Port

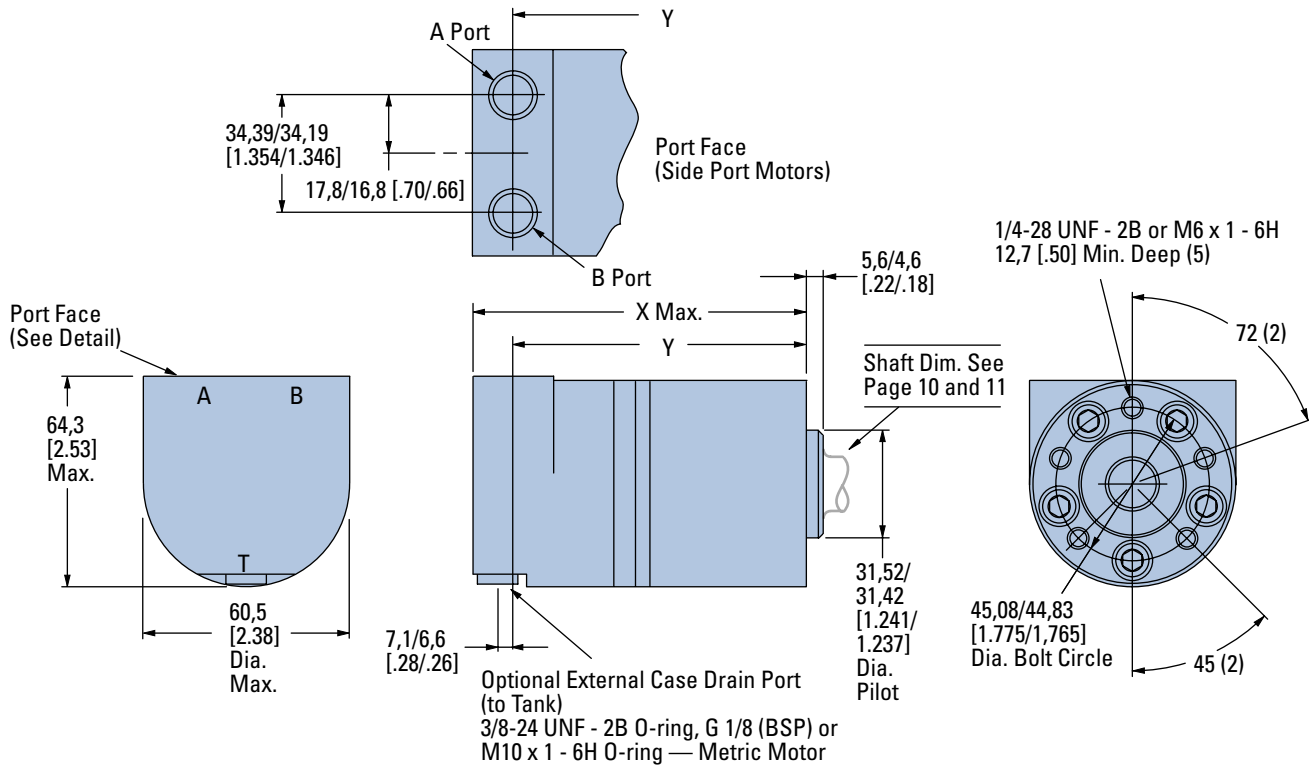

### SIDE PORT MOTORS

Displacement cm <sup>3</sup> /r [in <sup>3</sup> /r]	X mm [inch]	Y mm [inch]
8,2 [.50]	103,9 [4.09]	89,4/ 87,4 [3.52/3.44]
12,9 [.79]	106,9 [4.21]	92,5/ 90,4 [3.64/3.56]
19,8 [1.21]	112,5 [4.38]	96,8/ 94,7 [3.81/3.73]
31,6 [1.93]	118,9 [4.68]	104,4/102,4 [4.11/4.03]
50,0 [3.00]	130,0 [5.12]	115,7/113,9 [4.56/4.48]

# J Series (129-)

## Dimensions

Shafts

### 5/8 Inch Straight Keyed

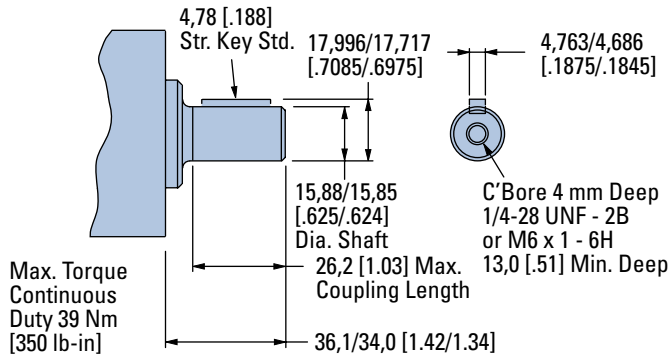

### 11/16 Inch Straight Keyed

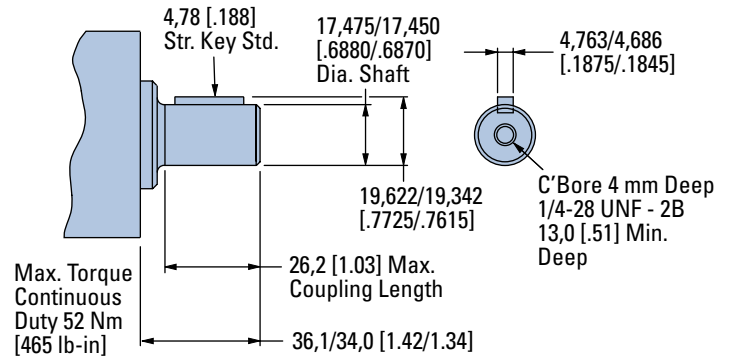

### 5/8 Inch Straight Keyed w/ Crosshole

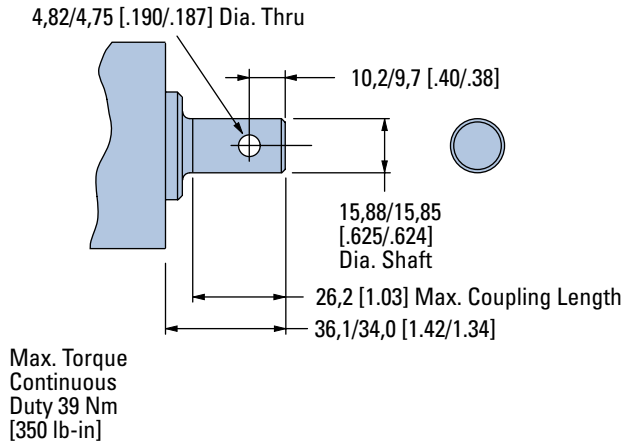

### 3/4 Inch Tapered

(Tapered Shaft End Per SAE J744)

Except as Specified — 1.5 : 12 Ratio)

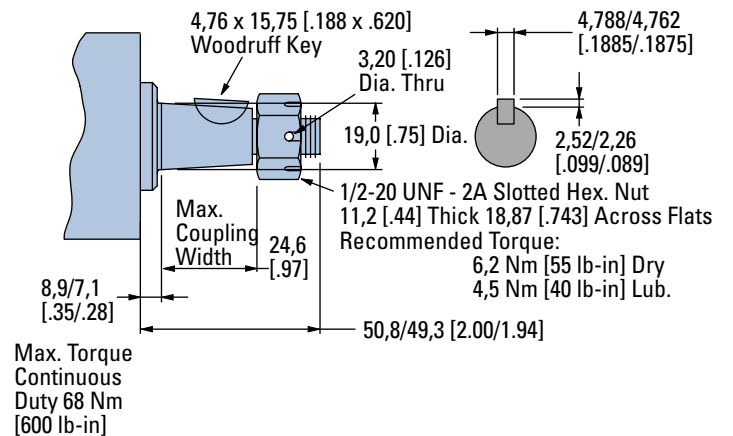

# J Series (129-)

## Dimensions

Shafts and Flange Kit

### 16 mm Straight Keyed

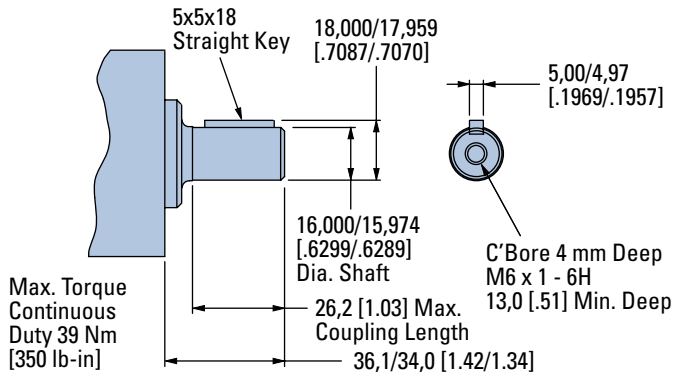

### 18 mm Straight Keyed

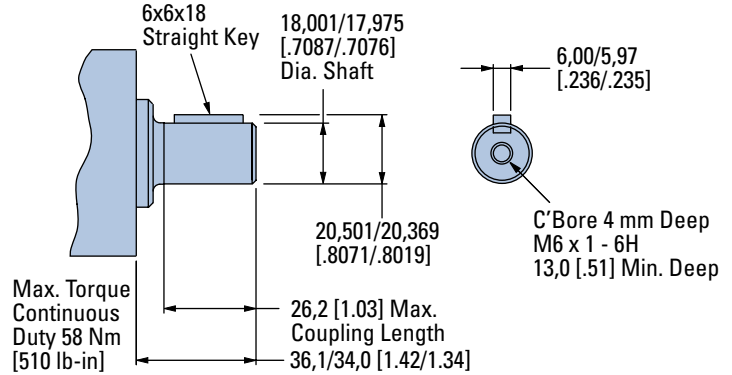

### Involute 9T Splined — Metric

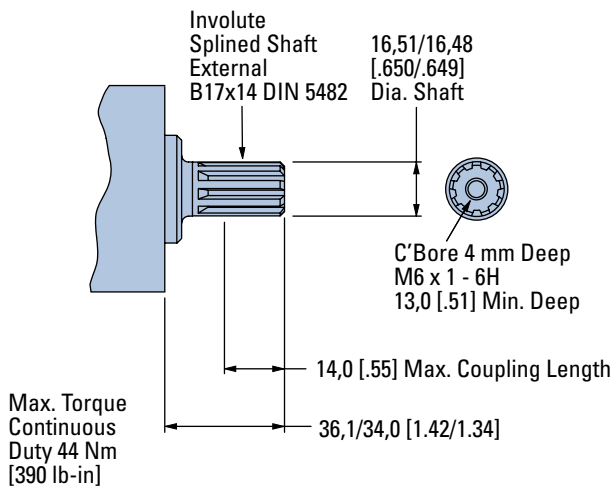

### 2 Bolt Flange Kits (2)

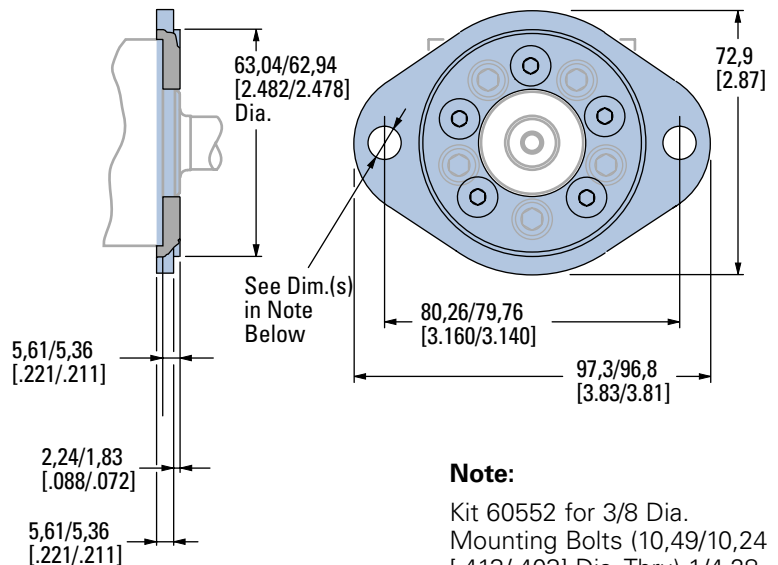

# J Series (129-)

## Product Numbers

Use digit prefix —  
129- plus four digit number  
from charts for complete  
product number—  
Example 129-0479.

**Orders will not be accepted  
without three digit prefix.**

### End Port

MOUNTING	SHAFT	PORT SIZE	DISPL. cm <sup>3</sup> /r [in <sup>3</sup> /r] / PRODUCT NUMBER				
			8,2 [.50]	12,9 [.79]	19,8 [1.21]	31,6 [1.93]	50,0 [3.00]
1/4-28 UNF 2B	5/8 inch Straight		129-0291	-0292	-0293	-0294	-0458
	11/16 inch Straight	9/16 -18 UNF	129-0295	-0296	-0297	-0298	-0459
	Splined — Metric	2B O-ring (2)	129-0299	-0300	-0301	-0302	-0460
	3/4 inch Tapered		129-0480				
M6 x 1 - 6H	16 mm Straight	M14 x 1,5 - 6H O-ring (2)	129-0303	-0304	-0305	-0306	-0461
	18 mm Straight		129-0307	-0308	-0309	-0310	-0462
	Splined — Metric		129-0311	-0312	-0313	-0314	-0463
	16 mm Straight	G 1/4 (BSP) (2)	129-0315	-0316	-0317	-0318	-0464
	18 mm Straight		129-0319	-0320	-0321	-0322	-0465
	Splined — Metric		129-0323	-0324	-0325	-0326	-0466
	16 mm Straight		129-0327	-0328	-0329	-0330	-0467
	18 mm Straight	G 3/8 (BSP) (2)*	129-0331	-0332	-0333	-0334	-0468
Splined — Metric	129-0335	-0336	-0337	-0338	-0469		

\*Note: The Same Casting used for Side Ports is Required for G 3/8 (BSP) End Ports

129-0336

### Side Port

MOUNTING	SHAFT	PORT SIZE	DISPL. cm <sup>3</sup> /r [in <sup>3</sup> /r] / PRODUCT NUMBER				
			8,2 [.50]	12,9 [.79]	19,8 [1.21]	31,6 [1.93]	50,0 [3.00]
1/4-28 UNF 2B	5/8 inch Straight		129-0339	-0340	-0341	-0342	-0470
	11/16 inch Straight	9/16 -18 UNF	129-0343	-0344	-0345	-0346	-0471
	Splined — Metric	2B O-ring (2)	129-0347	-0348	-0349	-0350	-0472
	3/4 inch Tapered		129-0481				
M6 x 1 - 6H	16 mm Straight	M14 x 1,5 - 6H O-ring (2)	129-0351	-0352	-0353	-0354	-0473
	18 mm Straight		129-0355	-0356	-0357	-0358	-0474
	Splined — Metric		129-0359	-0360	-0361	-0362	-0475
	16 mm Straight	G 1/4 (BSP) (2)	129-0363	-0364	-0365	-0366	-0476
	18 mm Straight		129-0367	-0368	-0369	-0370	-0477
	Splined — Metric		129-0371	-0372	-0373	-0374	-0403
	18 mm Straight		G 3/8 (BSP) (2)	129-0375	-0376	-0377	-0378
	Splined — Metric	129-0379	-0380	-0381	-0382	-0479	

Two Bolt Mounting Flange Kit (for 3/8 inch Mounting Bolts) — Kit Number 60552 (includes 5 screws — 1/4 -28 UNF-2B)

Two Bolt Mounting Flange Kit (for M8 Mounting Bolts ) — Kit Number 60553 (includes 5 screws — M6 x 1-6H)

# J Series (129-)

## Shaft Side Load Capacity

The hydrodynamic bearing has infinite life when shaft load ratings are not exceeded. Hence, the shaft side load capacity is more than adequate to handle most externally applied loads (such as belts, chains, etc.), providing the motor to shaft size is applied within its torque rating.

Allowable side load chart, shaft load location drawing (right) and load curves

(below) are based on the side or radial loads being applied to shaft at locations A, B, and C, to determine the shaft side load capacity at locations other than those shown use the formula (shown below). For more information about shaft side loads on Char-Lynn motors contact your Eaton representative.

**ALLOWABLE SIDE LOAD — KG [LB]**

RPM	A	B	C
2300	29 [ 64]	24 [ 53]	20 [ 43]
1500	44 [ 98]	37 [ 82]	30 [ 66]
1250	54 [118]	44 [ 98]	36 [ 79]
1000	67 [147]	55 [122]	45 [ 99]
750	89 [196]	74 [163]	60 [132]
600	111 [245]	93 [204]	75 [165]
500	133 [294]	111 [245]	90 [198]
400	167 [368]	139 [306]	112 [248]
340	196 [432]	163 [360]	132 [291]

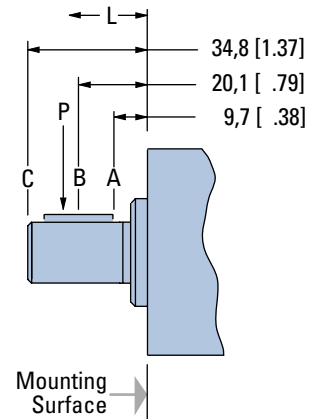
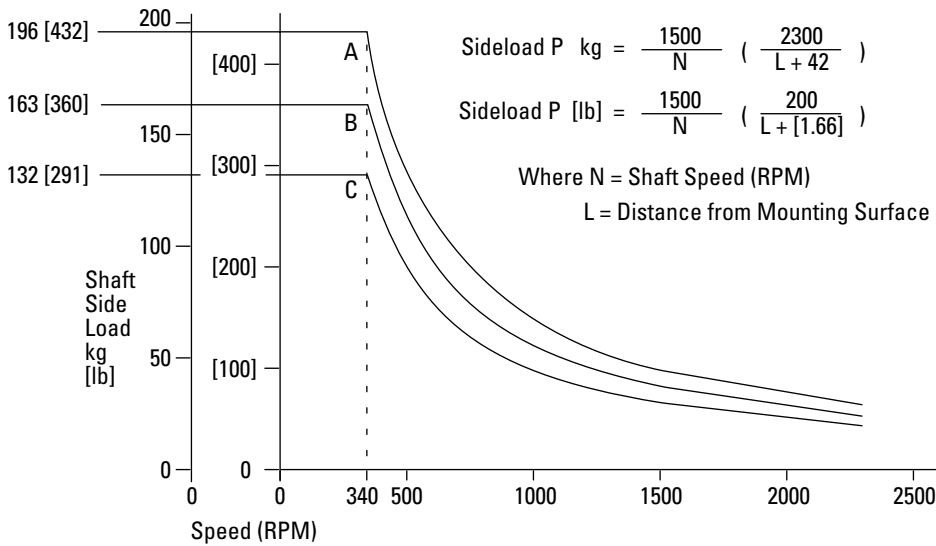

# J Series (129-)

## Case Pressure and Case Drain

The J Series now offers check valves in the motor as a standard feature. This addition reduces the case pressure in the motor to the return pressure of the system when the case drain is not used. For return pressures higher than the rated pressures (see chart) the external case drain can be connected. If the case drain line is needed, connect drain line to assure that the motor will always remain full of fluid.

### Case Drain Advantage

In addition to providing lower case pressures for motors connected in series, there are advantages for adding an external case drain line to motors with normal case pressures as well. These advantages are:

**Contamination Control** — flushing the motor case.

**Motor Cooler** — exiting oil draws motor heat away.

**Extend Motor Seal Life** — maintain low case pressure with a preset restriction installed in the case drain line

### Example:

A 14 Bar case pressure will cause a load of 40 kg, so the allowable thrust load will be 82 kg plus 40 = 120 kg pushing inward on shaft. Tension load is 82 kg under all case pressure conditions.

### Example:

A 200 PSI case pressure will cause a load of 88 lbs, so the allowable thrust load will be 180 lbs plus 88 = 268 lbs pushing inward on shaft. Tension load is 180 lb under all case pressure conditions

### Note:

J Series motors can be connected in parallel or in series.

Case pressure will add to the allowable compressive thrust load. Case pressure will push outward on the shaft at 20 kg/7 Bar [44 lb/100 PSI].

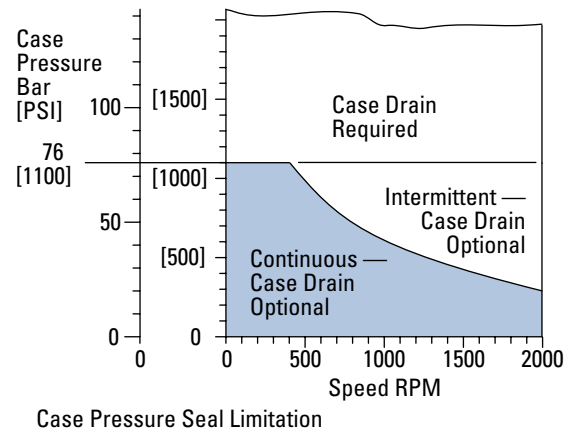
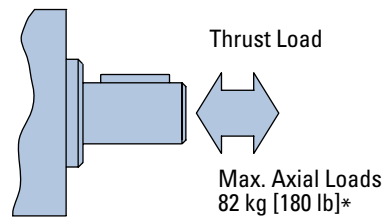
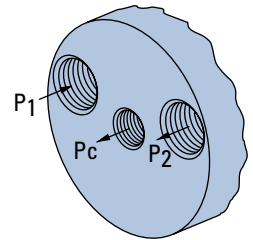

# J Series (129-)

## Model Code

The following 16-digit coding system has been developed to identify all of the configuration options for the J motor. Use this model code to specify a motor with the desired features. All 16-digits of the code must be present when ordering. You may want to photocopy the matrix below to ensure that each number is entered in the correct box.

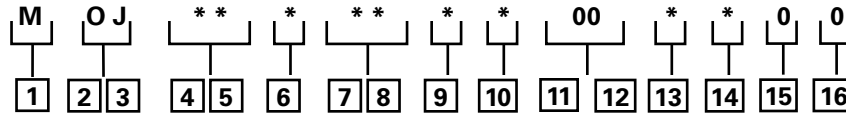

### **1** Product

**M** – Motor

### **2**, **3** Series

**OJ** – J Series

### **4**, **5** Displacement cm<sup>3</sup>/r [in<sup>3</sup>/r]

**05** – 8,2 [.50]

**08** – 12,9 [.79]

**12** – 19,8 [1.21]

**19** – 31,6 [1.93]

**30** – 50,0 [3.00]

### **6** Mounting Type

**A** – 5 Bolt: Dia. 31,47 [1.239] x 5,1 [.20] Pilot 1/4-28 UNF 2B Mounting Holes on 45 [1.77] Dia. Bolt Circle

**B** – 5 Bolt: Dia. 31,47 [1.239] x 5,1 [.20] Pilot M6 x 1- 6H Mounting Holes on 45 [1.77] Dia. Bolt Circle

**C** – 2 Bolt: Dia. 62,99 [2.480] x 2,0 [.08] Pilot 10,36 [.408] Mounting Holes on 80,0 [3.150] Dia. Bolt Circle

**D** – 2 Bolt: Dia. 62,99 [2.480] x 2,0 [.08] Pilot 9,0 [.354] Mounting Holes on 80,0 [3.150] Dia. Bolt Circle

### **7**, **8** Output Shaft

**01** – 5/8 inch Dia. Straight with 4,72 [.186] Square Key and 1/4-28 UNF - 2B Threaded Hole

**02** – 16 mm Dia. Straight with 5,00 [.197] Square Key with M6 x 1 - 6H Threaded Hole

**04** – 11/16 inch Dia. Straight with 4,72 [.186] Square Key and 1/4-28 UNF - 2B Threaded Hole

**05** – 18 mm Dia. Straight with 5,92 [.233] Square Key with M6 x 1 - 6H Threaded Hole

**06** – Involute Splined 9T—Metric 16,50 [.650] Dia. (B17 x 14 DIN 5482) M6 x 1 - 6H Threaded Hole

**07** – 5/8 inch Dia. Straight with 4,75 [.187] Dia. Crosshole

**08** – 3/4 inch Tapered with Woodruff Key and Nut

**09** – 5/8 inch Dia. Straight with 4,72 [.186] Sq. Key with 1/4-28 UNF -2B Threaded Hole (Plated for Corrosion Protection)

**14** – 16 mm Dia. Straight with 5,00 [.197] Sq. Key with M6 x 1- 6H Threaded Hole (Plated for Corrosion Protection)

### **9** Ports

**A** – 9/16 -18 UNF - 2B O-ring End Ported

**B** – G 1/4 (BSP) End Ported

**C** – M14 x 1,5 - 6H O-ring Port, End Ported

**D** – 9/16 -18 UNF - 2B O-ring Side Ported

**E** – G 3/8 (BSP) Side Ported

**F** – G 1/4 (BSP) Side Ported

**H** – G 3/8 (BSP) End Ported

### **10** Case Flow Options

**0** – No Case Drain

**1** – 3/8 -24 UNF - 2B O-ring

**2** – G 1/8 (BSP)

**3** – M10 x 1 - 6H O-ring

### **11**, **12** Special Features (Hardware)

**00** – None

### **13** Special Features (Assembly)

**0** – None

**1** – Reverse Rotation

### **14** Paint/Special Packaging

**0** – No Paint, Individual Box

**A** – Painted Low Gloss Black, Individual Box

**B** – No Paint, Bulk Box Option

### **15** Eaton Assigned Code when Applicable

**0** – Assigned Code

### **16** Eaton Assigned Design Code

**0** – Assigned Design Code



# H Series (101-)

## Highlights

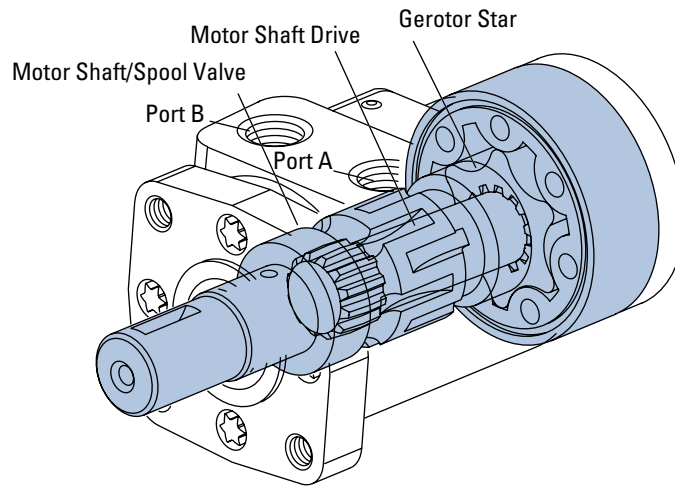

### Description

Designed for medium duty applications, these motors use industry-proven spool valve technology combined with state-of-the-art gerotors. In addition, a wide variety of mounting flanges, shafts, ports and valving options provide design flexibility. Direction of shaft rotation and shaft speed can be controlled easily and smoothly throughout the speed range of the motor, and equipment can be driven direct, eliminating costly mechanical components.

### Specifications

Gerotor Element	13 Displacements
Flow l/min [GPM]	57 [15] Continuous***
	76 [20] Intermittent**
Speed	Up to 1100 RPM
Pressure bar [PSI]	125 [1800] Cont.***
	165 [2400] Inter.**
Torque Nm [lb-in]	407 [3604] Cont.***
	520 [4600] Inter.**

\*\*\* Continuous—(Cont.) Continuous rating, motor may be run continuously at these ratings.

\*\* Intermittent—(Inter.) Intermittent operation, 10% of every minute.

### Features:

- Time-tested Char-Lynn drive set
- Three moving components (gerotor-star, drive, and shaft)
- Optimized drive running angle
- Three-zone pressure design (inlet, return and case)
- Variety of displacements, shafts and mounts
- Special options to meet customer needs

### Benefits:

- High efficiency
- Powerful compact package
- Design flexibility
- Extended leak-free performance

### Applications:

- Agricultural augers, harvesters, seeders
- Car wash brushes
- Food processing
- Railroad maintenance equipment
- Machine tools
- Conveyors
- Industrial sweepers and floor polishers
- Saw mill works
- Turf equipment
- Concrete and asphalt equipment
- Skid steer attachments
- Many more



Conveyer



Combine



Sweeper



Salt and Sand Spreader

# H Series (101-)

## Specifications

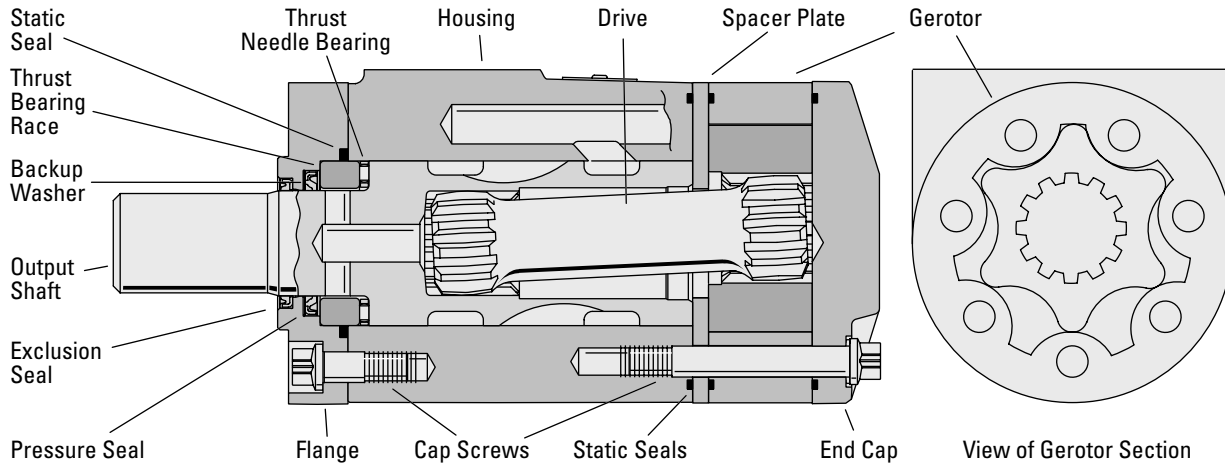

### SPECIFICATION DATA — H MOTORS

Displ. cm <sup>3</sup> /r [in <sup>3</sup> /r]		36 [2.2]	46 [2.8]	59 [3.6]	74 [4.5]	97 [5.9]	120 [7.3]	146 [8.9]	159 [9.7]	185 [11.3]	231 [14.1]	293 [17.9]	370 [22.6]	739 [45.1]
Max. Speed (RPM) @ Continuous Flow		1021	969	953	760	585	469	385	353	304	243	192	152	74
Flow LPM [GPM]	Continuous	38 [10]	45 [12]	57 [15]	57 [15]	57 [15]	57 [15]	57 [15]	57 [15]	57 [15]	57 [15]	57 [15]	57 [15]	57 [15]
	Intermittent	38 [10]	53 [14]	64 [17]	68 [18]	68 [18]	76 [20]	76 [20]	76 [20]	76 [20]	76 [20]	76 [20]	76 [20]	76 [20]
Torque Nm [lb-in]	Continuous	56 [497]	73 [650]	91 [802]	118 [1044]	155 [1368]	192 [1699]	221 [1954]	233 [2059]	265 [2343]	302 [2669]	351 [3110]	407 [3604]	389 [3440]
	Intermittent	75 [668]	99 [876]	122 [1076]	158 [1401]	207 [1829]	257 [2278]	300 [2653]	319 [2824]	356 [3151]	415 [3671]	466 [4121]	484 [4283]	520 [4600]
Min. Starting Torque @ Int. Pressure	@ Cont. Pressure	46 [410]	59 [520]	76 [670]	95 [840]	124 [1100]	154 [1360]	176 [1560]	186 [1650]	211 [1870]	238 [2110]	282 [2500]	330 [2920]	316 [2800]
	@ Int. Pressure	63 [560]	81 [720]	104 [920]	130 [1150]	171 [1510]	2102 [1860]	46 [2180]	262 [2320]	293 [2590]	339 [3000]	388 [3430]	408 [3610]	434 [3840]
Pressure ΔBar [Δ PSI]	Continuous	124 [1800]	124 [1800]	124 [1800]	124 [1800]	124 [1800]	124 [1800]	117 [1700]	114 [1650]	110 [1600]	100 [1450]	93 [1350]	86 [1250]	41 [600]
	Intermittent	165 [2400]	165 [2400]	165 [2400]	165 [2400]	165 [2400]	165 [2400]	159 [2300]	155 [2250]	148 [2150]	138 [2000]	124 [1800]	103 [1500]	55 [800]
Weight kg [lb]		5,1 [11.2]	5,1 [11.2]	5,2 [11.5]	5,2 [11.5]	5,4 [11.8]	5,5 [12.1]	5,6 [12.4]	5,7 [12.5]	5,8 [12.8]	6,0 [13.3]	6,3 [14.0]	6,7 [14.7]	8,4 [18,6]

A simultaneous maximum torque and maximum speed NOT recommended.

#### Note:

To assure best motor life, run motor for approximately one hour at 30% of rated pressure before application to full load. Be sure motor is filled with fluid prior to any load applications.

#### Maximum Inlet Pressure:

172 Bar [2500 PSI] without regard to Δ Bar [D PSI] and/or back pressure ratings or combination thereof.

6B splined or Tapered shafts are recommended whenever operation above 282 NM [2500 lb-in] of torque, especially for those applications subject to frequent reversals.

#### Δ Pressure:

The true Δ bar [Δ PSI] difference between inlet port and outlet port

#### Continuous Rating:

Motor may be run continuously at these ratings

#### Intermittent Operation:

10% of every minute

#### Recommended Fluids:

Premium quality, anti-wear type hydraulic oil with a viscosity of not less than 70 SUS at operating temperature.

#### Recommended Maximum System Operating Temp.:

82°C [180°F]

#### Recommended Filtration:



per ISO Cleanliness Code 4406, level 20/18/13

# H Series (101-)

## Performance Data



Motors run with high efficiency in all areas designated with a number for torque and speed, however for best motor life select a motor to run with a torque and speed range printed in the light shaded area.

Performance data is typical at 120 SUS. Actual data may vary slightly from unit to unit in production.

 Continuous  
 Intermittent

**36 cm<sup>3</sup>/r [2.2 in<sup>3</sup>/r]**  
 Δ Pressure Bar [PSI]  
 Continuous

		[200]	[400]	[600]	[800]	[1000]	[1200]	[1400]	[1600]	[1800]	[2400]
		14	28	41	55	69	83	97	110	124	165
Flow LPM [GPM]	[2]	[49]	[103]	[162]	[189]	[270]	[325]	[379]	[432]	[489]	[650]
	7,6	6 204	12 201	18 198	21 194	31 189	37 184	43 177	49 170	55 162	73 122
	[4]	[47]	[106]	[160]	[191]	[274]	[327]	[384]	[439]	[495]	[654]
	15,1	5 408	12 407	18 402	22 399	31 394	37 387	43 381	50 373	56 365	74 323
[6]	[44]	[102]	[158]	[188]	[272]	[328]	[383]	[440]	[496]	[661]	
22,7	5 613	12 612	18 609	21 604	31 599	37 591	43 586	50 576	56 565	75 523	
[8]	[40]	[97]	[153]	[184]	[270]	[326]	[383]	[440]	[497]	[668]	
30,3	5 817	11 817	17 814	21 807	31 799	37 793	43 785	50 776	56 762	75 721	
[10]	[36]	[90]	[148]	[180]	[265]	[322]	[380]	[438]	[495]	[664]	
Max. Continuous 37,9	4 1021	10 1021	17 1015	20 1008	30 1001	36 991	43 981	49 969	56 959	75 920	

 } Torque [lb-in]  
 10 } Nm  
 } Speed RPM

**46 cm<sup>3</sup>/r [2.8 in<sup>3</sup>/r]**  
 Δ Pressure Bar [PSI]  
 Continuous

		[200]	[400]	[600]	[800]	[1000]	[1200]	[1400]	[1600]	[1800]	[2400]
		14	28	41	55	69	83	97	110	124	165
Flow LPM [GPM]	[2]	[64]	[136]	[212]	[284]	[355]	[426]	[497]	[567]	[641]	[852]
	7,6	7 161	15 158	24 156	32 153	40 148	48 145	56 139	64 133	72 127	96 95
	[4]	[61]	[139]	[209]	[286]	[359]	[429]	[503]	[576]	[649]	[857]
	15,1	7 323	16 320	24 316	32 314	41 310	48 304	57 300	65 293	73 287	97 253
[6]	[58]	[134]	[207]	[282]	[356]	[430]	[502]	[577]	[650]	[867]	
22,7	7 486	15 481	23 479	32 475	40 471	49 464	57 461	65 453	73 444	98 410	
[8]	[52]	[128]	[200]	[276]	[354]	[428]	[502]	[577]	[651]	[876]	
30,3	6 648	14 643	23 640	31 635	40 628	48 623	57 617	65 610	74 599	99 566	
[10]	[47]	[118]	[194]	[269]	[347]	[423]	[498]	[575]	[649]	[871]	
37,9	5 808	13 803	22 798	30 793	39 787	48 779	56 771	65 761	73 753	98 722	
[12]	[36]	[109]	[188]	[260]	[340]	[417]	[492]	[567]	[643]	[864]	
Max. Continuous 45,4	4 969	12 964	21 960	29 952	38 946	47 938	56 931	64 922	73 914	98 877	
Max. Intermittent 53,0	[14]	[25]	[98]	[175]	[249]	[327]	[404]	[484]	[559]	[634]	
	3 1127	11 1123	20 1115	28 1108	37 1100	46 1093	55 1086	63 1079	72 1068		

# H Series (101-)

## Performance Data

Motors run with high efficiency in all areas designated with a number for torque and speed, however for best motor life select a motor to run with a torque and speed range printed in the light shaded area.

Performance data is typical at 120 SUS. Actual data may vary slightly from unit to unit in production.

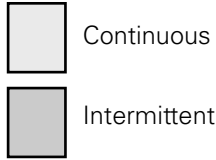

**59 cm<sup>3</sup>/r [3.6 in<sup>3</sup>/r]**

□ Pressure Bar [PSI]  
Continuous

Max.  
Contin-  
uous

Max.  
Inter-  
mittent

		[200]	[400]	[600]	[800]	[1000]	[1200]	[1400]	[1600]	[1800]	[2400]	
		14	28	41	55	69	83	97	110	124	165	
Flow LPM [GPM]	[2] 7,6	[79] 9 127	[169] 19 125	[260] 29 123	[305] 34 121	[437] 49 117	[526] 59 114	[616] 70 109	[704] 80 103	[796] 90 96	[1055] 119 65	
	[4] 15,1	[76] 9 254	[168] 19 254	[257] 29 251	[307] 35 249	[441] 50 246	[529] 60 241	[620] 70 236	[710] 80 230	[800] 90 224	[1065] 120 193	
	[6] 22,7	[73] 8 381	[161] 18 381	[252] 28 380	[303] 34 377	[439] 50 373	[529] 60 368	[618] 70 364	[709] 80 358	[802] 91 349	[1069] 121 319	
	[8] 30,3	[64] 7 508	[151] 17 508	[243] 27 508	[294] 33 504	[428] 48 500	[519] 59 496	[609] 69 491	[701] 79 484	[794] 90 476	[1076] 122 446	
	[10] 37,9	[57] 6 635	[141] 16 635	[234] 26 634	[283] 32 630	[419] 47 626	[512] 58 621	[602] 68 614	[693] 78 608	[786] 89 601	[1071] 121 571	
	[12] 45,4	[45] 5 762	[131] 15 762	[227] 26 762	[274] 31 757	[409] 46 753	[505] 57 747	[593] 67 741	[684] 77 734	[778] 88 728	[1058] 120 694	
	[14] 53,0	[33] 4 889	[118] 13 889	[213] 24 887	[266] 30 882	[396] 45 877	[492] 56 872	[583] 66 866	[676] 76 860	[770] 87 851	[1055] 119 813	
	Max. Contin- uous	[15] 56,8	[29] 3 953	[111] 13 953	[205] 23 951	[260] 29 945	[389] 44 940	[486] 55 935	[576] 65 929	[670] 76 921	[765] 86 913	[1055] 119 872
	Max. Inter- mittent	[20] 75,7	[17] 2 1080	[98] 11 1080	[192] 22 1077	[252] 28 1071	[377] 43 1067	[475] 54 1062	[567] 64 1055	[660] 75 1049	[757] 86 1040	

**74 cm<sup>3</sup>/r [4.5 in<sup>3</sup>/r]**

□ Pressure Bar [PSI]  
Continuous

Max.  
Contin-  
uous

Max.  
Inter-  
mittent

		[200]	[400]	[600]	[800]	[1000]	[1200]	[1400]	[1600]	[1800]	[2400]	
		14	28	41	55	69	83	97	110	124	165	
Flow LPM [GPM]	[2] 7,6	[103] 12 101	[220] 25 99	[339] 38 98	[454] 51 96	[569] 64 93	[685] 77 90	[801] 91 86	[916] 103 81	[1036] 117 76	[1373] 155 51	
	[4] 15,1	[99] 11 203	[219] 25 201	[335] 38 199	[457] 52 197	[574] 65 194	[689] 78 191	[808] 91 187	[925] 105 182	[1042] 118 177	[1386] 157 153	
	[6] 22,7	[94] 11 305	[210] 24 303	[328] 37 301	[451] 51 298	[571] 65 296	[689] 78 292	[805] 91 288	[924] 104 283	[1044] 118 276	[1392] 157 252	
	[8] 30,3	[86] 10 406	[196] 22 404	[319] 36 402	[438] 49 399	[558] 63 396	[676] 76 393	[793] 90 388	[913] 103 383	[1033] 117 377	[1401] 158 352	
	[10] 37,9	[74] 8 507	[183] 21 505	[310] 35 502	[422] 48 499	[545] 62 496	[667] 75 492	[784] 89 486	[903] 102 482	[1024] 116 476	[1394] 158 452	
	[12] 45,4	[58] 7 608	[171] 19 606	[295] 33 603	[408] 46 600	[533] 60 596	[657] 74 591	[773] 87 587	[891] 101 581	[1013] 114 576	[1377] 156 549	
	[14] 53,0	[43] 5 709	[154] 17 706	[277] 31 702	[396] 45 698	[515] 58 694	[640] 72 691	[760] 86 686	[880] 99 681	[1002] 113 674	[1374] 155 643	
	Max. Contin- uous	[15] 56,8	[36] 4 760	[145] 16 757	[268] 30 753	[387] 44 749	[506] 57 744	[632] 71 740	[750] 85 735	[873] 99 729	[996] 113 723	[1373] 155 690
	Max. Inter- mittent	[20] 75,7	[14] 2 904	[121] 14 902	[233] 26 898	[351] 40 895	[482] 54 891	[609] 69 887	[725] 82 882	[856] 97 877	[981] 111 869	

# H Series (101-)

## Performance Data

Motors run with high efficiency in all areas designated with a number for torque and speed, however for best motor life select a motor to run with a torque and speed range printed in the light shaded area.

Performance data is typical at 120 SUS. Actual data may vary slightly from unit to unit in production.

	Continuous
	Intermittent

		97 cm <sup>3</sup> /r [5.9 in <sup>3</sup> /r]								Max. Continuous	Max. Intermittent
		Δ Pressure Bar [PSI]									
		Continuous									
		[200]	[400]	[600]	[800]	[1000]	[1200]	[1400]	[1600]	[1800]	[2400]
		14	28	41	55	69	83	97	110	124	165
Flow LPM [GPM]	[2]	[134]	[292]	[442]	[593]	[746]	[899]	[1054]	[1209]	[1365]	[1806]
	7,6	15 78	33 76	50 75	67 73	84 71	102 68	119 65	137 61	154 55	204 33
	[4]	[131]	[281]	[436]	[596]	[750]	[903]	[1059]	[1212]	[1367]	[1828]
	15,1	15 156	32 155	49 153	67 151	85 149	102 147	120 143	137 139	154 134	207 113
	[6]	[126]	[269]	[425]	[588]	[747]	[900]	[1054]	[1206]	[1368]	[1823]
	22,7	14 234	30 233	48 231	66 230	84 228	102 224	119 221	136 217	155 210	206 189
	[8]	[110]	[246]	[408]	[566]	[718]	[873]	[1023]	[1177]	[1339]	[1829]
	30,3	12 312	28 311	46 310	64 308	81 305	99 303	116 300	133 295	151 291	207 269
	[10]	[96]	[231]	[392]	[539]	[699]	[859]	[1005]	[1156]	[1318]	[1821]
	37,9	11 390	26 389	44 387	61 385	79 383	97 380	114 376	131 373	149 368	206 346
[12]	[77]	[218]	[378]	[522]	[681]	[844]	[990]	[1142]	[1301]	[1792]	
45,4	9 468	25 467	43 465	59 463	77 460	95 457	112 453	129 449	147 445	202 421	
[14]	[60]	[197]	[358]	[513]	[662]	[828]	[973]	[1131]	[1293]	[1776]	
53,0	7 546	22 544	40 542	58 539	75 537	94 535	110 531	128 526	146 521	201 499	
Max. Continuous	[15]	[52]	[189]	[346]	[495]	[651]	[819]	[963]	[1126]	[1286]	[1778]
56,8	6 585	21 583	39 581	56 578	74 575	93 573	109 569	127 564	145 559	201 536	
Max. Intermittent	[20]	[25]	[157]	[311]	[455]	[625]	[790]	[941]	[1110]	[1272]	
75,7	3 701	18 700	35 697	51 694	71 691	89 688	106 684	125 681	144 674		



		120 cm <sup>3</sup> /r [7.3 in <sup>3</sup> /r]								Max. Continuous	Max. Intermittent
		Δ Pressure Bar [PSI]									
		Continuous									
		[200]	[400]	[600]	[800]	[1000]	[1200]	[1400]	[1600]	[1800]	[2400]
		14	28	41	55	69	83	97	110	124	165
Flow LPM [GPM]	[2]	[162]	[357]	[544]	[736]	[927]	[1116]	[1305]	[1498]	[1687]	[2231]
	7,6	18 62	40 61	61 61	83 59	105 58	126 55	147 53	169 49	191 45	252 26
	[4]	[160]	[348]	[539]	[736]	[930]	[1119]	[1316]	[1506]	[1698]	[2268]
	15,1	18 125	39 124	61 123	83 121	105 120	126 119	149 116	170 114	192 110	256 90
	[6]	[155]	[338]	[530]	[729]	[923]	[1116]	[1310]	[1500]	[1699]	[2271]
	22,7	18 188	38 187	60 186	82 185	104 183	126 180	148 178	169 175	192 170	257 152
	[8]	[139]	[319]	[515]	[710]	[901]	[1094]	[1283]	[1476]	[1673]	[2278]
	30,3	16 250	36 250	58 249	80 247	102 245	124 243	145 241	167 237	189 233	257 216
	[10]	[121]	[303]	[497]	[686]	[883]	[1081]	[1267]	[1460]	[1655]	[2268]
	37,9	14 313	34 312	56 311	78 309	100 308	122 306	143 302	165 300	187 296	256 278
[12]	[102]	[288]	[480]	[664]	[862]	[1060]	[1246]	[1440]	[1640]	[2232]	
45,4	12 375	33 374	54 373	75 371	97 370	120 367	141 365	163 361	185 358	252 338	
[14]	[78]	[263]	[458]	[652]	[841]	[1041]	[1228]	[1420]	[1616]	[2213]	
53,0	9 438	30 437	52 435	74 433	95 431	118 430	139 427	160 423	183 419	250 401	
Max. Continuous	[15]	[67]	[253]	[446]	[632]	[828]	[1030]	[1214]	[1411]	[1608]	[2205]
56,8	8 469	29 468	50 466	71 464	94 462	116 460	137 458	159 454	182 450	249 430	
Max. Intermittent	[20]	[20]	[202]	[384]	[581]	[778]	[971]	[1169]	[1356]	[1559]	
75,7	2 626	23 624	43 621	66 618	88 617	110 614	132 611	153 609	176 606		

# H Series (101-)

## Performance Data

Motors run with high efficiency in all areas designated with a number for torque and speed, however for best motor life select a motor to run with a torque and speed range printed in the light shaded area.

Performance data is typical at 120 SUS. Actual data may vary slightly from unit to unit in production.

 Continuous  
 Intermittent

**146 cm<sup>3</sup>/r [8.9 in<sup>3</sup>/r]**

**Δ Pressure Bar [PSI]**

Continuous

Max. Continuous

Max. Intermittent

		[200]	[400]	[600]	[800]	[1000]	[1200]	[1400]	[1600]	[1700]	[2300]
		14	28	41	55	69	83	97	110	117	159
Flow LPM [GPM]	[2]	[198]	[435]	[664]	[897]	[1130]	[1361]	[1591]	[1827]	[1942]	[2611]
	7,6	22 51	49 50	75 50	101 49	128 47	154 45	180 43	206 40	219 39	295 24
	[4]	[196]	[424]	[657]	[898]	[1133]	[1365]	[1604]	[1836]	[1954]	[2648]
	15,1	22 103	48 102	74 101	101 99	128 99	154 97	181 95	207 93	221 92	299 78
	[6]	[189]	[412]	[646]	[889]	[1125]	[1361]	[1598]	[1829]	[1951]	[2653]
	22,7	21 154	47 153	73 152	100 151	127 150	154 148	181 146	207 143	220 141	300 128
	[8]	[169]	[389]	[628]	[866]	[1098]	[1333]	[1564]	[1799]	[1919]	[2649]
	30,3	19 205	44 205	71 204	98 203	124 201	151 200	177 197	203 195	217 193	299 180
	[10]	[148]	[369]	[605]	[836]	[1076]	[1318]	[1544]	[1780]	[1899]	[2789]
	37,9	17 257	42 256	68 255	94 253	122 252	149 251	174 248	201 246	215 244	315 231
[12]	[125]	[351]	[586]	[810]	[1051]	[1293]	[1519]	[1756]	[1878]	[2606]	
45,4	14 308	40 307	66 306	92 305	119 303	146 301	172 299	198 296	212 295	294 281	
[14]	[95]	[321]	[558]	[795]	[1026]	[1290]	[1497]	[1731]	[1851]	[2580]	
53,0	11 359	36 358	63 357	90 355	116 354	146 352	169 350	196 347	209 346	292 331	
Max. Continuous	[15]	[82]	[308]	[544]	[771]	[1010]	[1256]	[1480]	[1720]	[1840]	[2569]
56,8	9 85	35 384	61 383	87 381	114 379	142 378	167 375	194 373	208 371	290 356	
Max. Intermittent	[20]	[24]	[246]	[468]	[708]	[948]	[1184]	[1425]	[1653]	[1780]	
75,7	3 513	28 512	53 509	80 507	107 506	134 504	161 501	187 499	201 498		

**159 cm<sup>3</sup>/r [9.7 in<sup>3</sup>/r]**

**Δ Pressure Bar [PSI]**

Continuous

Max. Continuous

Max. Intermittent

		[200]	[400]	[600]	[800]	[1000]	[1200]	[1400]	[1600]	[1650]	[2250]
		14	28	41	55	69	83	97	110	134	155
Flow LPM [GPM]	[2]	[209]	[465]	[715]	[973]	[1228]	[1478]	[1724]	[1981]	[2046]	[2764]
	7,6	24 47	53 46	81 46	110 45	139 44	167 42	195 40	224 38	231 37	312 23
	[4]	[210]	[460]	[710]	[971]	[1229]	[1480]	[1745]	[1996]	[2059]	[2813]
	15,1	24 94	52 94	80 93	110 91	139 91	167 90	197 89	226 87	233 87	318 76
	[6]	[205]	[454]	[704]	[965]	[1216]	[1477]	[1738]	[1991]	[2055]	[2824]
	22,7	23 141	51 141	80 140	109 139	137 138	167 136	196 134	225 132	232 132	319 119
	[8]	[186]	[440]	[693]	[951]	[1205]	[1461]	[1716]	[1973]	[2038]	[2808]
	30,3	21 188	50 188	78 187	107 186	136 185	165 183	194 181	223 179	230 178	317 166
	[10]	[164]	[422]	[671]	[930]	[1189]	[1451]	[1702]	[1965]	[2032]	[2789]
	37,9	19 235	48 234	76 234	105 232	134 232	164 230	192 228	219 226	230 225	315 213
[12]	[144]	[404]	[652]	[900]	[1163]	[1421]	[1674]	[1937]	[2004]	[2770]	
45,4	16 282	46 281	74 281	102 279	131 279	161 277	189 275	219 273	226 272	313 260	
[14]	[109]	[374]	[623]	[883]	[1140]	[1396]	[1653]	[1900]	[1963]	[2727]	
53,0	12 330	42 329	70 328	100 327	129 325	158 323	187 322	215 319	222 319	308 306	
Max. Continuous	[15]	[92]	[359]	[612]	[861]	[1123]	[1381]	[1633]	[1886]	[1950]	[2712]
56,8	10 353	41 352	69 351	97 350	127 348	156 347	185 345	213 343	220 342	306 330	
Max. Intermittent	[20]	[26]	[268]	[510]	[772]	[1034]	[1290]	[1553]	[1802]	[1865]	
75,7	3 471	30 470	58 467	87 465	117 464	146 462	175 460	204 458	211 458		

[359] } Torque [lb-in]  
 41 } Nm  
 352 } Speed RPM

# H Series (101-)

## Performance Data

Motors run with high efficiency in all areas designated with a number for torque and speed, however for best motor life select a motor to run with a torque and speed range printed in the light shaded area.

Performance data is typical at 120 SUS. Actual data may vary slightly from unit to unit in production.

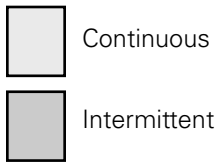

**185 cm<sup>3</sup>/r [11.3 in<sup>3</sup>/r]**

**Δ Pressure Bar [PSI]**

Continuous

Max. Continuous

Max. Intermittent

		[200]	[400]	[600]	[800]	[1000]	[1200]	[1400]	[1600]	
		14	28	41	55	69	83	97	110	[2150]
										148
Flow LPM [GPM]	[2]	[257]	[554]	[847]	[1150]	[1447]	[1739]	[2035]	[2320]	[3103]
	7,6	29 40	63 40	96 39	130 38	163 37	196 36	230 33	262 29	351 12
	[4]	[254]	[546]	[845]	[1145]	[1448]	[1744]	[2049]	[2343]	[3147]
	15,1	29 81	62 81	95 80	129 79	164 78	197 77	232 76	265 74	356 63
	[6]	[246]	[540]	[834]	[1137]	[1434]	[1736]	[2036]	[2337]	[3151]
	22,7	28 121	61 121	94 120	128 120	162 119	196 117	230 115	264 112	356 100
	[8]	[224]	[520]	[820]	[1117]	[1414]	[1716]	[2014]	[2315]	[3133]
	30,3	25 162	59 162	93 161	126 160	160 159	194 157	228 155	262 152	354 140
	[10]	[202]	[499]	[793]	[1095]	[1394]	[1699]	[1997]	[2299]	[3112]
	37,9	23 202	56 202	90 201	124 201	158 200	192 198	226 196	260 193	352 181
[12]	[176]	[475]	[767]	[1063]	[1368]	[1664]	[1969]	[2268]	[3088]	
45,4	20 243	54 242	87 242	120 241	155 240	188 238	222 236	256 234	349 222	
[14]	[140]	[443]	[735]	[1035]	[1340]	[1637]	[1936]	[2227]	[3051]	
53,0	16 283	50 283	83 282	117 281	151 280	185 279	219 277	252 274	345 262	
Max. Continuous	[15]	[120]	[425]	[719]	[1014]	[1320]	[1618]	[1914]	[2205]	[3023]
	56,8	14 304	48 303	81 302	115 301	149 300	183 299	216 297	249 294	342 283
Max. Intermittent	[20]	[27]	[321]	[612]	[911]	[1211]	[1504]	[1795]		
	75,7	3 405	36 404	69 402	103 401	137 400	170 398	203 397		

**231 cm<sup>3</sup>/r [14.1 in<sup>3</sup>/r]**

**Δ Pressure Bar [PSI]**

Continuous

Max. Continuous

Max. Intermittent

		[200]	[400]	[600]	[800]	[1000]	[1200]	[1400]	[1450]	
		14	28	41	55	69	83	97	100	[2000]
										138
Flow LPM [GPM]	[2]	[338]	[707]	[1074]	[1456]	[1827]	[2192]	[2572]	[2657]	
	7,6	38 32	80 32	121 31	165 30	206 30	248 28	291 26	300 25	
	[4]	[328]	[695]	[1076]	[1447]	[1827]	[2201]	[2577]	[2669]	[3671]
	15,1	37 65	79 65	122 64	163 63	206 62	249 62	291 60	302 60	415 50
	[6]	[317]	[687]	[1057]	[1434]	[1811]	[2186]	[2555]	[2650]	[3668]
	22,7	36 97	78 97	119 97	162 96	205 95	247 94	289 92	299 91	414 80
	[8]	[289]	[659]	[1038]	[1406]	[1777]	[2160]	[2531]	[2625]	[3644]
	30,3	33 130	74 130	117 130	159 129	201 128	244 127	286 124	297 124	412 112
	[10]	[265]	[631]	[1004]	[1381]	[1751]	[2131]	[2510]	[2602]	[3608]
	37,9	30 162	71 162	113 162	156 162	198 160	241 158	284 156	294 156	408 145
[12]	[230]	[599]	[968]	[1345]	[1722]	[2088]	[2480]	[2571]	[3571]	
45,4	26 195	68 195	109 194	152 194	195 193	236 192	280 189	290 189	403 178	
[14]	[191]	[563]	[927]	[1299]	[1686]	[2058]	[2428]	[2519]	[3532]	
53,0	22 227	64 227	105 227	147 226	190 226	233 224	274 222	285 221	399 212	
Max. Continuous	[15]	[167]	[538]	[904]	[1279]	[1661]	[2030]	[2404]	[2493]	[3488]
	56,8	19 243	61 243	102 243	145 242	188 242	229 240	272 238	282 238	394 229
Max. Intermittent	[20]	[29]	[411]	[785]	[1152]	[1520]	[1877]	[2222]	[2318]	
	75,7	3 324	46 324	89 323	130 322	172 322	212 320	251 319	262 318	

# H Series (101-)

## Performance Data

Motors run with high efficiency in all areas designated with a number for torque and speed, however for best motor life select a motor to run with a torque and speed range printed in the light shaded area.

Performance data is typical at 120 SUS. Actual data may vary slightly from unit to unit in production.

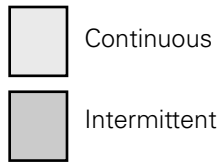

		293 cm <sup>3</sup> /r [17.9 in <sup>3</sup> /r]						Max. Continuous	Max. Intermittent
		Δ Pressure Bar [PSI]							
		[200]	[400]	[600]	[800]	[1000]	[1200]	[1350]	[1800]
		14	28	41	55	69	83	93	124
Flow LPM [GPM]	[2] 7,6	[427] 48 26	[893] 101 25	[1361] 154 25	[1829] 207 24	[2293] 259 22	[2672] 302 16	[2977] 336 13	
	[4] 15,1	[419] 47 51	[886] 100 51	[1362] 154 51	[1833] 207 50	[2305] 260 49	[2771] 313 47	[3110] 351 44	[4107] 464 22
	[6] 22,7	[402] 45 77	[872] 99 77	[1342] 152 76	[1819] 206 76	[2291] 259 74	[2757] 312 71	[3098] 350 68	[4121] 466 54
	[8] 30,3	[367] 41 102	[838] 95 102	[1316] 149 102	[1785] 202 101	[2252] 254 100	[2733] 308 98	[3070] 347 95	[4086] 462 84
	[10] 37,9	[332] 38 128	[803] 91 128	[1276] 144 128	[1749] 198 127	[2215] 250 126	[2684] 303 123	[3034] 343 120	[4061] 459 108
	[12] 45,4	[289] 33 153	[760] 86 153	[1230] 139 153	[1706] 193 153	[2177] 246 151	[2634] 298 149	[2989] 338 146	[4012] 453 135
	[14] 53,0	[241] 27 179	[712] 80 179	[1176] 133 179	[1650] 186 179	[2126] 240 177	[2592] 293 175	[2935] 332 172	[3963] 448 161
	Max. Continuous 56,8	[211] 24 192	[683] 77 192	[1149] 130 192	[1623] 183 191	[2096] 237 190	[2558] 289 188	[2905] 328 185	[3914] 442 174
	Max. Intermittent 75,7	[43] 5 256	[527] 60 256	[1001] 113 255	[1463] 165 255	[1919] 217 254	[2375] 268 252	[2720] 307 249	

		370 cm <sup>3</sup> /r [22.6 in <sup>3</sup> /r]						Max. Continuous	Max. Intermittent			739 cm <sup>3</sup> /r [45.1 in <sup>3</sup> /r]			Max. Continuous	Max. Intermittent	
		Δ Pressure Bar [PSI]										Δ Pressure Bar [PSI]					
		[200]	[400]	[600]	[800]	[1000]	[1200]	[1250]	[1500]			[200]	[400]	[600]	[800]		
		14	28	41	55	69	83	86	103			14	28	41	55		
Flow LPM [GPM]	[2] 7,6	[537] 61 20	[1121] 127 20	[1715] 194 20	[2285] 258 19	[2862] 323 16						[2] 7,6	[1080] 122 10	[2250] 254 10	[3440] 389 10	[4570] 516 9	
	[4] 15,1	[532] 60 40	[1123] 127 40	[1715] 194 40	[2308] 261 39	[2893] 327 38	[3467] 392 36	[3604] 407 35	[4274] 483 27			[4] 15,1	[1070] 121 20	[2250] 254 20	[3440] 389 19	[4600] 520 18	
	[6] 22,7	[508] 57 61	[1100] 124 61	[1693] 191 61	[2294] 259 60	[2884] 326 58	[3458] 391 55	[3598] 407 53	[4283] 484 47			[6] 22,7	[1020] 115 30	[2200] 249 30	[3390] 383 29	[4590] 519 27	
	[8] 30,3	[463] 52 81	[1060] 120 81	[1661] 188 81	[2255] 255 80	[2840] 321 79	[3414] 386 76	[3557] 402 74	[4254] 481 68			[8] 30,3	[ 945] 107 40	[2135] 241 40	[3330] 376 39	[4515] 510 37	
	[10] 37,9	[414] 47 101	[1017] 115 101	[1613] 182 101	[2203] 249 101	[2788] 315 99	[3363] 380 96	[3506] 396 94	[4212] 476 88			[10] 37,9	[ 840] 95 50	[2050] 232 50	[3250] 367 48	[4430] 501 46	
	[12] 45,4	[363] 41 121	[960] 108 121	[1553] 175 121	[2152] 243 121	[2737] 309 119	[3305] 373 116	[3446] 389 115	[4152] 469 109			[12] 45,4	[ 740] 84 60	[1945] 220 59	[3130] 354 58	[4320] 488 55	
	[14] 53,0	[303] 34 142	[897] 101 142	[1484] 168 142	[2086] 236 142	[2667] 301 140	[3246] 367 137	[3386] 383 136	[4092] 462 130			[14] 53,0	[ 630] 71 69	[1820] 206 68	[3005] 340 68	[4195] 474 66	
	Max. Continuous 56,8	[266] 30 152	[862] 97 152	[1452] 164 152	[2050] 232 152	[2630] 297 150	[3206] 362 148	[3347] 378 147	[4054] 458 140			Max. Continuous 56,8	[ 540] 61 74	[1735] 196 74	[2905] 328 73	[4130] 467 72	
	Max. Intermittent 75,7	[20] 7 202	[61] 76 202	[1269] 143 202	[1847] 209 202	[2410] 272 202	[2987] 337 199	[3119] 352 198				Max. Intermittent 75,7	[ 143] 16 99	[1350] 153 98	[2565] 290 97	[3705] 419 96	

[862] } Torque [lb-in]  
97 } Nm  
152 } Speed RPM



# H Series (101-)

## Dimensions

(Refer to pages B-4-19 thru B-4-22 for shaft and port dimensions.)

### Standard Rotation Viewed from Shaft End

Port A Pressurized — CW

Port B Pressurized — CCW

### Note:

Mounting surface flatness requirement is  $\square$ , 13 mm [.005 inch] Max.

### Note:

End ported motor pressure is derated to 1400 psi cont., 1700 psi intermittent.

## 2 Bolt Flange

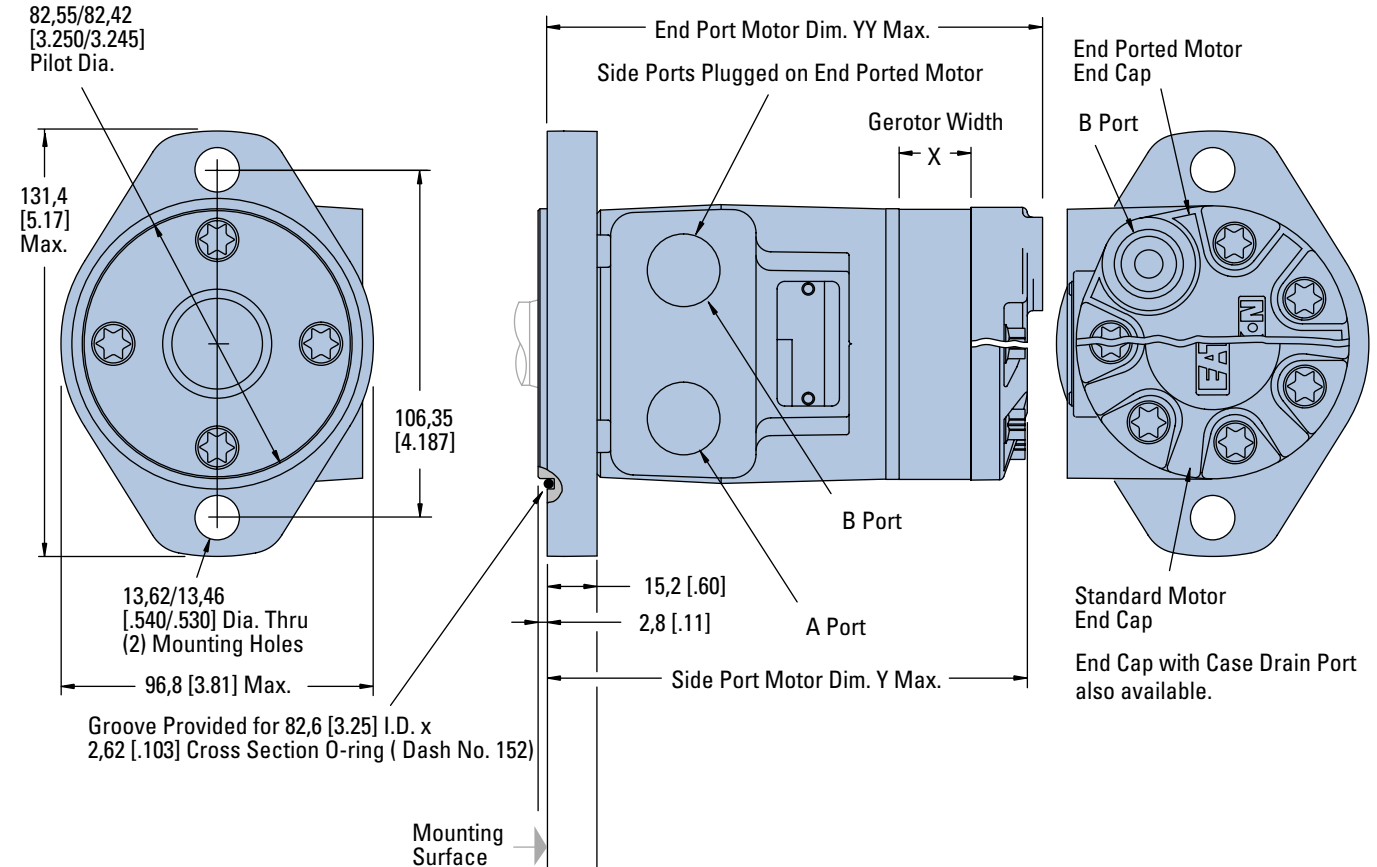

## 4 Bolt Flange

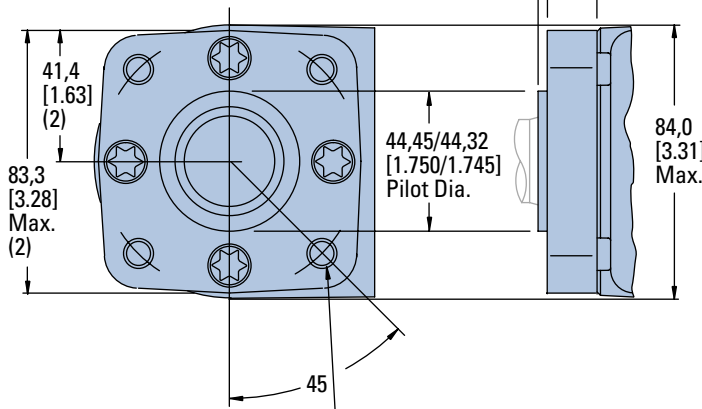

3/8-16 UNC (15,2 [.60] Max. Bolt Thread Engagement ) Mounting Holes (4) Equally Spaced on 82,6 [3.25] Dia. Bolt Circle or  
 M10 x 1,5 (15,2 [.60] Max. Bolt Thread Engagement ) Mounting Holes (4) Equally Spaced on 82,6 [3.25] Dia. Bolt Circle

### 2 AND 4 BOLT FLANGE

Displacement cm <sup>3</sup> /r [in <sup>3</sup> /r]	X mm [inch]	Y mm [inch]	YY mm [inch]
36 [ 2.2]	6,4 [ .25]	132,1 [5.20]	138,5 [5.45]
46 [ 2.8]	6,4 [ .25]	132,1 [5.20]	138,5 [5.45]
59 [ 3.6]	10,2 [ .40]	135,9 [5.35]	142,3 [5.60]
74 [ 4.5]	10,2 [ .40]	135,9 [5.35]	142,3 [5.60]
97 [ 5.9]	13,2 [ .52]	139,0 [5.47]	145,3 [5.72]
120 [ 7.3]	16,5 [ .65]	142,3 [5.60]	148,6 [5.85]
146 [ 8.9]	20,1 [ .79]	145,8 [5.74]	152,2 [5.99]
159 [ 9.7]	21,9 [ .86]	147,6 [5.81]	154,0 [6.06]
185 [11.3]	25,4 [1.00]	151,2 [5.95]	157,5 [6.20]
231 [14.1]	31,8 [1.25]	157,5 [6.20]	
293 [17.9]	40,4 [1.59]	166,2 [6.54]	
370 [22.6]	50,8 [2.00]	176,6 [6.95]	
739 [45.1]	101,6 [4.00]	227,4 [8.95]	

# H Series (101-)

## Product Numbers

Use digit prefix —101- plus four digit number from charts for complete product number—Example 101-1001. Orders will not be accepted without three digit prefix.

### 2 Bolt Flange

SHAFT	PORT SIZE	DISPL. cm <sup>3</sup> /r [in <sup>3</sup> /r] / PRODUCT NUMBER													
		36 [ 2.2]	46 [ 2.8]	59 [ 3.6]	74 [ 4.5]	97 [ 5.9]	120 [ 7.3]	146 [ 8.9]	159 [ 9.7]	185 [11.3]	231 [14.1]	293 [17.9]	370 [22.6]	740 [45.0]	
.1 in. Straight 7/8-14 O-ring	7/8-14 O-ring	101-1700	-1033	-1701	-1034	-1035	-1702	-1703	-1036	-1037	-1038	-1039	-1040	—	
	1/2 NPTF	101-1704	-1025	-1705	-1026	-1027	-1706	-1707	-1028	-1029	-1030	-1031	-1032	—	
	Manifold*	101-1708	-1041	-1709	-1042	-1043	-1710	-1711	-1044	-1045	-1046	-1047	-1048	—	
1 in. SAE 6B Splined	7/8-14 O-ring	101-1721	-1081	-1722	-1082	-1083	-1723	-1724	-1084	-1085	-1086	-1087	-1088	—	
	1/2 NPTF	101-1725	-1073	-1726	-1074	-1075	-1727	-1728	-1076	-1077	-1078	-1079	-1080	—	
	Manifold*	101-1729	-1089	-1730	-1090	-1091	-1731	-1732	-1092	-1093	-1094	-1095	-1096	—	
1 in. Straight w/ .31 Dia. Crosshole	7/8-14 O-ring	101-1796	-1797	-1798	-1799	-1800	-1801	-1802	-1803	—	—	—	—	—	
	1/2 NPTF	101-1804	-1805	-1806	-1807	-1808	-1870	-1809	-1810	—	—	—	—	—	
	Manifold*	101-1811	-1812	-1813	-1814	-1815	-1816	-1817	-1818	—	—	—	—	—	
1 in. Straight w/ .40 Dia. Crosshole	7/8-14 O-ring	101-1819	-1323	-1820	-1324	-1325	-1821	-1822	-1326	—	—	—	—	—	
	1/2 NPTF	101-1823	-1319	-1824	-1320	-1825	-1826	-1827	-1828	—	—	—	—	—	
	Manifold*	101-1829	-1463	-1830	-1831	-1832	-1833	-1834	-1871	—	—	—	—	—	

101-1834

### 4 Bolt Flange

SHAFT	PORT SIZE	DISPL. cm <sup>3</sup> /r [in <sup>3</sup> /r] / PRODUCT NUMBER													
		36 [ 2.2]	46 [ 2.8]	59 [ 3.6]	74 [ 4.5]	97 [ 5.9]	120 [ 7.3]	146 [ 8.9]	159 [ 9.7]	185 [11.3]	231 [14.1]	293 [17.9]	370 [22.6]	740 [45.0]	
1 in. Straight 7/8-14 O-ring	7/8-14 O-ring	101-1749	-1009	-1750	-1010	-1011	-1751	-1752	-1012	-1013	-1014	-1015	-1016	—	
	1/2 NPTF	101-1753	-1001	-1754	-1002	-1003	-1755	-1756	-1004	-1005	-1006	-1007	-1008	—	
	Manifold*	101-1757	-1017	-1758	-1018	-1019	-1759	-1760	-1020	-1021	-1022	-1023	-1024	—	
1 in. SAE 6B Splined	7/8-14 O-ring	101-1761	-1057	-1762	-1058	-1059	-1872	-1763	-1060	-1061	-1062	-1063	-1064	—	
	1/2 NPTF	101-1764	-1049	-1765	-1050	-1051	-1766	-1767	-1052	-1053	-1054	-1055	-1056	—	
	Manifold*	101-1768	-1065	-1769	-1066	-1067	-1770	-1771	-1068	-1069	-1070	-1071	-1072	—	
1 in. Straight w/ .31 Dia. Crosshole	7/8-14 O-ring	101-1835	-1836	-1837	-1838	-1839	-1840	-1841	-1842	—	—	—	—	—	
	1/2 NPTF	101-1843	-1497	-1844	-1449	-1352	-1845	-1846	-1847	—	—	—	—	—	
	Manifold*	101-1848	-1466	-1849	-1459	-1850	-1851	-1852	-1853	—	—	—	—	—	
1 in. Straight w/ .40 Dia. Crosshole	7/8-14 O-ring	101-1854	-1311	-1855	-1856	-1857	-1858	-1859	-1860	—	—	—	—	—	
	1/2 NPTF	101-1861	-1313	-1862	-1312	-1314	-1863	-1864	-1315	—	—	—	—	—	
	Manifold*	101-1865	-1305	-1866	-1306	-1307	-1867	-1868	-1869	—	—	—	—	—	

101-1868

### 4 Bolt Flange with Corrosion Protection

SHAFT	PORT SIZE	DISPL. cm <sup>3</sup> /r [in <sup>3</sup> /r] / PRODUCT NUMBER													
		36 [ 2.2]	46 [ 2.8]	59 [ 3.6]	74 [ 4.5]	97 [ 5.9]	120 [ 7.3]	146 [ 8.9]	159 [ 9.7]	185 [11.3]	231 [14.1]	293 [17.9]	370 [22.6]	740 [45.0]	
1 in. Straight w/ Woodruff Key	1/2 NPTF	101-2032	-2014	-2093	-2027	-2013	-2094	-2095	-2015	-2028	-2029	-2030	-2031	—	
	Manifold*		-2067							-2068	-2069				

\*Manifold product numbers shown are for motors with four 5/16-18 port face mounting threads. Manifold, manifold mounting o-rings and bolts are NOT included.

For H Series Motors with a configuration Not Shown in the charts above: Use the model code system on page B-2-11 to specify the product in detail.

# H Series (101-)

## Model Code

The following 16-digit coding system has been developed to identify all of the configuration options for the H motor. Use this model code to specify a motor with the desired features. All 16-digits of the code must be present when ordering. You may want to photocopy the matrix below to ensure that each number is entered in the correct box.

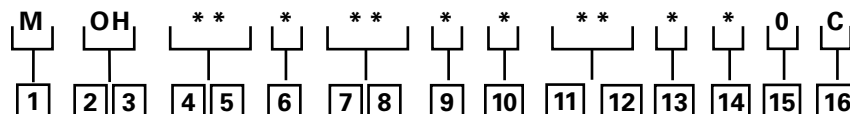

### 1 Product

**M** - Motor

### 2, 3 Series

**OH** - H Motor

### 4, 5 Displacement cm<sup>3</sup>/r [in<sup>3</sup>/r]

**02** - 36 [ 2.2]\*

**03** - 46 [ 2.8]

**04** - 59 [ 3.6]\*

**05** - 74 [ 4.5]

**06** - 97 [ 5.9]

**07** - 120 [ 7.3]

**09** - 146 [ 8.9]

**10** - 159 [ 9.7]

**11** - 185 [11.3]

**14** - 231 [14.1]

**18** - 293 [17.9]

**23** - 370 [22.6]

**45** - 739 [45.1]

### 6 Mounting Type

**A** - 2 Bolt (Standard) 82,6 [3.25] Pilot Dia. and 13,59 [.535] Dia. Mounting Holes 106,2 [4.18] Dia. B.C. Circle

**B** - 4 Bolt (Standard) 44,4 [1.75] Pilot Dia. and 3/8 -16 Mounting Holes 82,6 [3.25] Dia. B.C.

**E** - 4 Bolt (Standard) 44,4 [1.75] Pilot Dia. and M10 x 1,5 Mounting Holes 82,6 [3.25] Dia. B.C.

**F** - 4 Bolt Standard Mount (SAE CC) 127,00 [5.000] Pilot Dia. With 12,2 [.48] Pilot Length and 14,32 [.564] Dia. Holes on 161,92 [6.375] Dia. Bolt Circle

**H** - 2 Bolt (Std.) 101,6 [4.00] Pilot Dia. and 14,35 [.565] Dia. Mounting Holes 146,0 [5.75] Dia. B.C. (SAE B)

**H** - 4 Bolt Standard Mount

### 7, 8 Output Shaft

**01** - 1 inch Dia. Straight with Woodruff Key and 1/4-20 Threaded Hole

**02** - 1 inch Dia. SAE 6B Splined with 1/4-20 Threaded Hole

**07** - 1 inch Dia. Straight with 7,9 [.31] Dia. Crosshole 11,2 [.44] from End

**08** - 1 inch Dia. Straight with 10,2 [.40] Dia. Crosshole 15,7 [.62] from End and 1/4-20 Threaded Hole

**16** - 7/8 inch Dia. SAE B 13T Splined

**17** - 7/8 inch Dia. SAE B Straight with Square Key

**18** - 1 inch Dia. Tapered with Woodruff Key and Nut

**24** - 25mm Dia. Straight with 8mm Key and 8mm x 1,2 Threaded Hole

**27** - 1 inch Dia. Straight with Woodruff Key and 1/4-20 Threaded Hole (Plated for Corrosion Protection)

**29** - 25mm Dia. Straight with 8mm x 1.2 Threaded Hole (Plated for Corrosion Protection)

**32** - 1 inch Dia. Straight with 10,2 [.40] Dia. Crosshole 15,7 [.62] from End and 1/4-20 Threaded Hole (Plated...)

**33** - 1 inch Dia. Tapered with Woodruff Key and Nut (Plated for Corrosion Protection)

### 9 Ports

**A** - 7/8-14 O-ring

**B** - 1/2-14 NPTF

**C** - Manifold (5/16-18 Mounting Threads)

**D** - Manifold (M8 x 1,25 Mounting Threads)

**E** - G 1/2 (BSP)

**G** - 3/4-16 End Ported

**K** - G 1/2 (BSP) End Ported

### 10 Case Flow Options

**0** - No Case Drain

**1** - 7/16 -20 O-ring Port End Cap

**2** - G 1/4 (BSP) End Cap

### 11, 12 Special Features (Hardware)

**00** - None

**AA** - Free Running Gerotor

**AB** - Low Speed Valve

**AC** - Viton Shaft Seal

**BW** - Internal Check Valves

**BZ** - Speed Sensor

**AM** - Free Running Gerotor, Low Speed Valve

**DS** - High Pressure Shaft Seal

### 13 Special Features (Assembly)

**0** - None

**1** - Reverse Rotation

**2** - Flange Rotated 90°

### 14 Paint/ Special Packaging

**0** - No Paint, Individual Box

**A** - Painted Low Gloss Black, Individual Box

**B** - No Paint, Bulk Box Option

**C** - Painted Low Gloss Black, Bulk Box Option

### 15 Eaton Assigned Code when Applicable

**0** - Assigned Code

### 16 Eaton Assigned Design Code

**C** - Assigned Design Code

\*The H Series motors with displacement code "02" or "04" must also specify free running gerotor (option "AA" in positions 11, 12).

# Notes

# S Series (103-)

## Highlights

New, improved design!

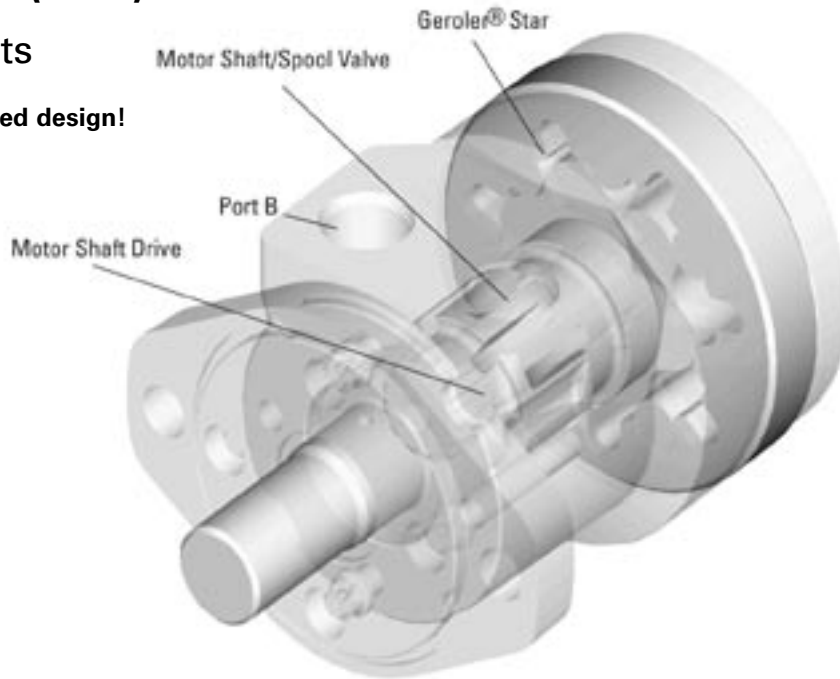

### Description

The new improved Char-Lynn S Series motors with optimized Geroler geometry offers enhanced performance with reduced drive-running angle while retaining the overall package size of the original S series. Design improvements include upgraded steel end cap, o-ring section seals, and optimized Geroler set. The Geroler set has precision-machined rollers in the outer ring which provide support with rolling contact between the star and ring. This improves mechanical efficiency, especially at start-up and at low speed conditions. Improvements incorporated into the latest S Series motor provide reliable leak-free performance and smooth operation at start-up conditions.

### Specifications

Geroler Element	10 Displacements
Flow l/min [GPM]	55 [15] Continuous*** 75 [20] Intermittent**
Speed	Up to 963 RPM
Pressure bar [PSI]	135 [2000] Cont.*** 170 [2500] Inter.**
Torque Nm [lb-in]	528 [4672] Cont.*** 587 [5190] Inter.**

\*\*\* Continuous— (Cont.) Continuous rating, motor may be run continuously at these ratings.  
\*\* Intermittent— (Inter.) Intermittent operation, 10% of every minute.

### Features:

- Constant clearance Geroler, design
- Three moving components (gerotor, drive, shaft)
- Optimized drive running angle
- Three-zone pressure design (inlet, return and case)
- Variety of displacements, shafts and mounts
- Special options to meet customer needs!

### Benefits:

- High efficiency
- Smooth low speed operation!
- Extended motor life
- Design flexibility
- Ability to optimize designs for your application needs
- Extended leak-free performance

### Applications:

- Agricultural augers, harvesters, seeders
- Car wash brushes
- Food processing
- Railroad maintenance equipment
- Machine tools
- Conveyors
- Industrial sweepers and floor polishers
- Saw mill works
- Turf equipment
- Concrete and asphalt equipment
- Skid steer attachments
- Many more



Conveyor



Casting



Amusement ride



Combine

# S Series (103-)

## Specifications

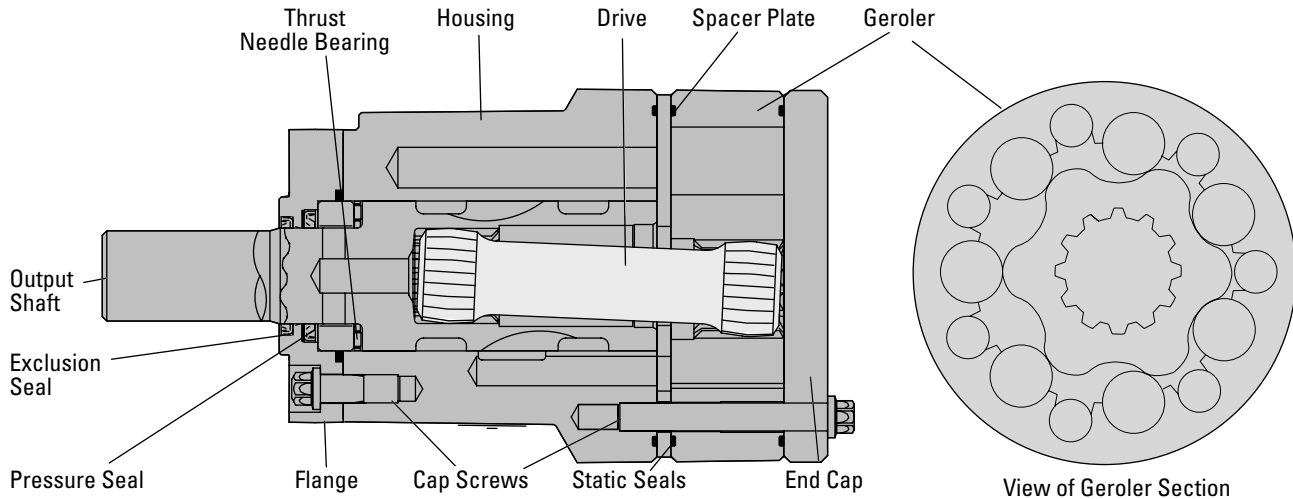

### SPECIFICATION DATA — S MOTORS

Displ. cm <sup>3</sup> /r [in <sup>3</sup> /r]		59 [ 3.6]	75 [ 4.6]	97 [ 5.7]	120 [ 7.3]	144 [ 8.8]	166 [ 10.1]	187 [11.4]	225 [13.7]	298 [18.2]	372 [22.7]
Max. Speed (RPM) @ Continuous Flow		963	792	607	472	394	343	304	253	190	153
Flow LPM [GPM]	Continuous	57 [15]	57 [15]	57 [15]	57 [15]	57 [15]	57 [15]	57 [15]	57 [15]	57 [15]	57 [15]
	Intermittent	68 [18]	76 [20]	76 [20]	76 [20]	76 [20]	76 [20]	76 [20]	76 [20]	76 [20]	76 [20]
Torque Nm [lb-in]	Continuous	115 [1021]	150 [1325]	183 [1623]	237 [2010]	265 [2347]	301 [2662]	333 [2950]	372 [3290]	491 [4345]	528 [4672]
	Intermittent	144 [1271]	186 [1649]	225 [1992]	292 [2582]	324 [2870]	360 [3191]	399 [3533]	434 [3843]	505 [4467]	587 [5200]
Min. Starting Torque Nm[lb-in]	@ Cont. Pressure	90 [ 800]	113 [1000]	148 [1310]	184 [1630]	212 [2050]	232 [2330]	263 [2670]	302 [2990]	338 [3270]	369 [3270]
	@ Int. Pressure	116 [1030]	146 [1290]	190 [1680]	236 [2090]	271 [2400]	289 [2560]	329 [2910]	374 [3310]	417 [3690]	438 [3880]
Pressure Bar [ PSI]	Continuous	138 [2000]	138 [2000]	138 [2000]	138 [2000]	131 [1900]	131 [1900]	128 [1850]	117 [1700]	103 [1500]	90 [1300]
	Intermittent	172 [2500]	172 [2500]	172 [2500]	172 [2500]	162 [2350]	159 [2300]	155 [2250]	141 [2050]	124 [1800]	103 [1500]

**A simultaneous maximum torque and maximum speed NOT recommended.**

#### Note:

To assure best motor life, run motor for approximately one hour at 30% of rated pressure before application to full load. Be sure motor is filled with fluid prior to any load applications.

#### Maximum Inlet Pressure:

172 Bar [2500 PSI] without regard to  $\Delta$  Bar [ $\Delta$  PSI] and/or back pressure ratings or combination thereof.

6B Splined or Tapered shafts are recommended whenever operating above 282 NM [2500 lb-in] of torque, especially for those applications subject to frequent reversals.

#### $\Delta$ Pressure:

The true  $\Delta$  bar [ $\Delta$  PSI] between inlet port and outlet port

#### Continuous Rating:

Motor may be run continuously at these ratings

#### Intermittent Operation:

10% of every minute

#### Recommended Fluids:

Premium quality, anti-wear type hydraulic oil with a viscosity of not less than 70 SUS at operating temperature.

#### Recommended Maximum System Operating Temp.:

82°C [180°F]

#### Recommended Filtration:



per ISO Cleanliness Code 4406, level 20/18/13

# S Series (103-)

## Performance Data

Motors run with high efficiency in all areas designated with a number for torque and speed, however for best motor life select a motor to run with a torque and speed range printed in the light shaded area.

Performance data is typical at 120 SUS. Actual data may vary slightly from unit to unit in production

 Continuous  
 Intermittent

### S Motor 59 cm<sup>3</sup>/r [3.6 in<sup>3</sup>/r]

Δ Pressure Bar [PSI]

	[200]	[400]	[600]	[800]	[1000]	[1200]	[1400]	[1600]	[1800]	[2000]	[2500]
	<b>14</b>	<b>28</b>	<b>41</b>	<b>55</b>	<b>69</b>	<b>83</b>	<b>97</b>	<b>110</b>	<b>124</b>	<b>138</b>	<b>172</b>
[2]	83	185	288	389	486	580	681	764	849	878	
<b>7,6</b>	<b>128</b>	<b>127</b>	<b>125</b>	<b>122</b>	<b>119</b>	<b>116</b>	<b>112</b>	<b>108</b>	<b>103</b>	<b>96</b>	
[4]	83	189	294	399	502	605	699	804	896	967	1227
<b>15,1</b>	<b>9</b>	<b>21</b>	<b>33</b>	<b>45</b>	<b>57</b>	<b>68</b>	<b>79</b>	<b>91</b>	<b>101</b>	<b>109</b>	<b>139</b>
[6]	76	182	289	395	500	606	691	813	918	1021	1271
<b>22,7</b>	<b>9</b>	<b>21</b>	<b>33</b>	<b>45</b>	<b>57</b>	<b>68</b>	<b>78</b>	<b>92</b>	<b>104</b>	<b>115</b>	<b>144</b>
[8]	70	172	279	386	492	598	676	806	908	1017	1269
<b>30,3</b>	<b>8</b>	<b>19</b>	<b>32</b>	<b>44</b>	<b>56</b>	<b>68</b>	<b>76</b>	<b>91</b>	<b>103</b>	<b>115</b>	<b>143</b>
[10]	52	160	266	373	478	584	652	793	898	1003	1262
<b>37,9</b>	<b>6</b>	<b>18</b>	<b>30</b>	<b>42</b>	<b>54</b>	<b>66</b>	<b>74</b>	<b>90</b>	<b>101</b>	<b>113</b>	<b>143</b>
[12]	41	146	252	359	465	571	628	781	886	991	1253
<b>45,4</b>	<b>5</b>	<b>17</b>	<b>28</b>	<b>41</b>	<b>53</b>	<b>65</b>	<b>71</b>	<b>88</b>	<b>100</b>	<b>112</b>	<b>142</b>
[14]	21	129	234	342	449	556	599	765	871	977	1239
<b>53,0</b>	<b>2</b>	<b>15</b>	<b>26</b>	<b>39</b>	<b>51</b>	<b>63</b>	<b>68</b>	<b>86</b>	<b>98</b>	<b>110</b>	<b>140</b>
[15]	24	121	228	336	442	547	589	758	864	972	1230
<b>56,8</b>	<b>3</b>	<b>14</b>	<b>26</b>	<b>38</b>	<b>50</b>	<b>62</b>	<b>67</b>	<b>86</b>	<b>98</b>	<b>110</b>	<b>139</b>
[18]	39	95	199	304	410	518	533	728	837	941	1206
<b>68,1</b>	<b>4</b>	<b>11</b>	<b>22</b>	<b>34</b>	<b>46</b>	<b>58</b>	<b>60</b>	<b>82</b>	<b>95</b>	<b>106</b>	<b>136</b>

### S Motor 75 cm<sup>3</sup>/r [4.6 in<sup>3</sup>/r]

Δ Pressure Bar [PSI]

	[200]	[400]	[600]	[800]	[1000]	[1200]	[1400]	[1600]	[1800]	[2000]	[2500]
	<b>14</b>	<b>28</b>	<b>41</b>	<b>55</b>	<b>69</b>	<b>83</b>	<b>97</b>	<b>110</b>	<b>124</b>	<b>138</b>	<b>172</b>
[2]	116	248	377	505	627	743	884	930	953	1073	
<b>7,6</b>	<b>13</b>	<b>28</b>	<b>43</b>	<b>57</b>	<b>71</b>	<b>84</b>	<b>100</b>	<b>105</b>	<b>108</b>	<b>121</b>	
[4]	114	251	388	523	656	788	916	1048	1170	1276	1455
<b>15,1</b>	<b>13</b>	<b>28</b>	<b>44</b>	<b>59</b>	<b>74</b>	<b>89</b>	<b>103</b>	<b>118</b>	<b>132</b>	<b>144</b>	<b>164</b>
[6]	110	243	382	518	657	792	906	1059	1196	1325	1631
<b>22,7</b>	<b>12</b>	<b>27</b>	<b>43</b>	<b>59</b>	<b>74</b>	<b>89</b>	<b>102</b>	<b>120</b>	<b>135</b>	<b>150</b>	<b>184</b>
[8]	100	234	371	507	646	780	888	1053	1188	1320	1649
<b>30,3</b>	<b>11</b>	<b>26</b>	<b>42</b>	<b>57</b>	<b>73</b>	<b>88</b>	<b>100</b>	<b>119</b>	<b>134</b>	<b>149</b>	<b>186</b>
[10]	77	216	353	491	626	762	859	1037	1168	1308	1641
<b>37,9</b>	<b>9</b>	<b>24</b>	<b>40</b>	<b>55</b>	<b>71</b>	<b>86</b>	<b>97</b>	<b>117</b>	<b>132</b>	<b>148</b>	<b>185</b>
[12]	63	204	331	473	606	745	828	1015	1153	1288	1626
<b>45,4</b>	<b>7</b>	<b>23</b>	<b>37</b>	<b>53</b>	<b>68</b>	<b>84</b>	<b>94</b>	<b>115</b>	<b>130</b>	<b>146</b>	<b>184</b>
[14]	42	173	324	450	587	723	787	995	1131	1268	1604
<b>53,0</b>	<b>5</b>	<b>20</b>	<b>37</b>	<b>51</b>	<b>66</b>	<b>82</b>	<b>89</b>	<b>112</b>	<b>128</b>	<b>143</b>	<b>181</b>
[15]	41	176	304	442	577	715	774	987	1123	1257	1591
<b>56,8</b>	<b>5</b>	<b>20</b>	<b>34</b>	<b>50</b>	<b>65</b>	<b>81</b>	<b>87</b>	<b>112</b>	<b>127</b>	<b>142</b>	<b>180</b>
[20]	36	107	234	368	506	642	644	916	1053	1187	1527
<b>75,7</b>	<b>4</b>	<b>12</b>	<b>26</b>	<b>42</b>	<b>57</b>	<b>73</b>	<b>73</b>	<b>103</b>	<b>119</b>	<b>134</b>	<b>173</b>

# S Series (103-)

## Performance Data

Motors run with high efficiency in all areas designated with a number for torque and speed, however for best motor life select a motor to run with a torque and speed range printed in the light shaded area.

Performance data is typical at 120 SUS. Actual data may vary slightly from unit to unit in production

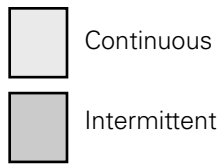

### S Motor 93 cm<sup>3</sup>/r [5.7 in<sup>3</sup>/r] Δ Pressure Bar [PSI]

	[200]	[400]	[600]	[800]	[1000]	[1200]	[1400]	[1600]	[1800]	[2000]	[2500]
	<b>14</b>	<b>28</b>	<b>41</b>	<b>55</b>	<b>69</b>	<b>83</b>	<b>97</b>	<b>110</b>	<b>124</b>	<b>138</b>	<b>172</b>
[2]	143	306	463	617	766	876	1080	1020	1129	1182	
	16	35	52	70	87	99	122	115	128	134	
	<b>7,6</b>	<b>77</b>	<b>72</b>	<b>65</b>	<b>57</b>	<b>48</b>	<b>36</b>	<b>24</b>	<b>11</b>	<b>9</b>	<b>1</b>
[4]	150	318	487	652	819	982	1141	1288	1425	1558	1570
	17	36	55	74	92	111	129	146	161	176	177
	<b>15,1</b>	<b>157</b>	<b>153</b>	<b>146</b>	<b>138</b>	<b>128</b>	<b>119</b>	<b>105</b>	<b>90</b>	<b>76</b>	<b>64</b>
[6]	134	302	473	639	808	977	1119	1306	1466	1623	1980
	15	34	53	72	91	110	126	148	166	183	224
	<b>22,7</b>	<b>240</b>	<b>236</b>	<b>230</b>	<b>223</b>	<b>215</b>	<b>207</b>	<b>195</b>	<b>185</b>	<b>167</b>	<b>151</b>
[8]	121	286	453	619	786	955	1083	1286	1448	1607	1992
	14	32	51	70	89	108	122	145	164	182	225
	<b>30,3</b>	<b>322</b>	<b>317</b>	<b>311</b>	<b>303</b>	<b>294</b>	<b>284</b>	<b>272</b>	<b>260</b>	<b>246</b>	<b>187</b>
[10]	97	266	433	600	766	934	1050	1264	1428	1588	1974
	11	30	49	68	87	106	119	143	161	179	223
	<b>37,9</b>	<b>403</b>	<b>398</b>	<b>392</b>	<b>383</b>	<b>374</b>	<b>364</b>	<b>352</b>	<b>337</b>	<b>323</b>	<b>262</b>
[12]	78	246	412	578	742	913	1012	1240	1402	1563	1952
	9	28	47	65	84	103	114	140	158	177	221
	<b>45,4</b>	<b>485</b>	<b>479</b>	<b>473</b>	<b>465</b>	<b>454</b>	<b>444</b>	<b>431</b>	<b>418</b>	<b>401</b>	<b>340</b>
[14]	52	217	383	550	711	881	962	1212	1375	1538	1927
	6	24	43	62	80	99	109	137	155	174	218
	<b>53,0</b>	<b>566</b>	<b>560</b>	<b>554</b>	<b>545</b>	<b>536</b>	<b>525</b>	<b>512</b>	<b>498</b>	<b>483</b>	<b>420</b>
[15]	47	207	372	539	707	867	943	1197	1357	1521	1917
	5	23	42	61	80	98	106	135	153	172	217
	<b>56,8</b>	<b>607</b>	<b>602</b>	<b>596</b>	<b>588</b>	<b>580</b>	<b>570</b>	<b>558</b>	<b>545</b>	<b>529</b>	<b>467</b>
[20]	10	113	277	444	612	776	776	1111	1276	1445	1844
	1	13	31	50	69	88	88	126	144	163	208
	<b>75,7</b>	<b>811</b>	<b>805</b>	<b>800</b>	<b>793</b>	<b>785</b>	<b>775</b>	<b>764</b>	<b>751</b>	<b>736</b>	<b>671</b>

### S Motor 120 cm<sup>3</sup>/r [7.3 in<sup>3</sup>/r] Δ Pressure Bar [PSI]

	[200]	[400]	[600]	[800]	[1000]	[1200]	[1400]	[1600]	[1800]	[2000]	[2500]
	<b>14</b>	<b>28</b>	<b>41</b>	<b>55</b>	<b>69</b>	<b>83</b>	<b>97</b>	<b>110</b>	<b>124</b>	<b>138</b>	<b>172</b>
[2]	191	402	613	817	1017	1207	1430	1542	1657	1725	
	22	45	69	92	115	136	162	174	187	195	
	<b>7,6</b>	<b>57</b>	<b>57</b>	<b>54</b>	<b>49</b>	<b>45</b>	<b>39</b>	<b>34</b>	<b>26</b>	<b>16</b>	<b>7</b>
[4]	193	411	630	846	1059	1271	1480	1684	1884	2075	2480
	22	46	71	96	120	144	167	190	213	234	280
	<b>15,1</b>	<b>124</b>	<b>121</b>	<b>117</b>	<b>114</b>	<b>109</b>	<b>104</b>	<b>97</b>	<b>90</b>	<b>81</b>	<b>72</b>
[6]	159	397	616	832	1051	1269	1456	1692	1897	2098	2575
	18	45	70	94	119	143	165	191	214	237	291
	<b>22,7</b>	<b>174</b>	<b>183</b>	<b>179</b>	<b>175</b>	<b>170</b>	<b>163</b>	<b>157</b>	<b>149</b>	<b>140</b>	<b>102</b>
[8]	156	374	590	808	1026	1242	1414	1670	1879	2085	2582
	18	42	67	91	116	140	160	189	212	236	292
	<b>30,3</b>	<b>250</b>	<b>247</b>	<b>243</b>	<b>238</b>	<b>233</b>	<b>227</b>	<b>219</b>	<b>211</b>	<b>202</b>	<b>160</b>
[10]	129	345	561	780	997	1214	1364	1637	1847	2056	2560
	15	39	63	88	113	137	154	185	209	232	289
	<b>37,9</b>	<b>313</b>	<b>311</b>	<b>307</b>	<b>302</b>	<b>297</b>	<b>291</b>	<b>283</b>	<b>275</b>	<b>266</b>	<b>227</b>
[12]	99	319	535	749	968	1184	1312	1609	1820	2031	2536
	11	36	60	85	109	134	148	182	206	230	286
	<b>45,4</b>	<b>377</b>	<b>375</b>	<b>370</b>	<b>365</b>	<b>359</b>	<b>353</b>	<b>345</b>	<b>337</b>	<b>328</b>	<b>287</b>
[14]	67	285	501	709	934	1150	1240	1578	1789	1995	2512
	8	32	57	80	106	130	140	178	202	225	284
	<b>53,0</b>	<b>440</b>	<b>437</b>	<b>434</b>	<b>428</b>	<b>423</b>	<b>416</b>	<b>409</b>	<b>400</b>	<b>390</b>	<b>350</b>
[15]	63	272	485	699	912	1128	1224	1552	1764	1969	2487
	7	31	55	79	103	127	138	175	199	222	281
	<b>56,8</b>	<b>472</b>	<b>469</b>	<b>464</b>	<b>459</b>	<b>445</b>	<b>438</b>	<b>429</b>	<b>419</b>	<b>407</b>	<b>373</b>
[20]	19	159	369	585	801	1018	1024	1444	1657	1867	2386
	2	18	42	66	91	115	116	163	187	211	270
	<b>75,7</b>	<b>631</b>	<b>627</b>	<b>624</b>	<b>619</b>	<b>614</b>	<b>607</b>	<b>600</b>	<b>591</b>	<b>582</b>	<b>542</b>



# S Series (103-)

## Performance Data

Motors run with high efficiency in all areas designated with a number for torque and speed, however for best motor life select a motor to run with a torque and speed range printed in the light shaded area.

Performance data is typical at 120 SUS. Actual data may vary slightly from unit to unit in production

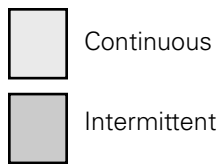

### S Motor 144 cm<sup>3</sup>/r [8.8 in<sup>3</sup>/r] Δ Pressure Bar [PSI]

	[200]	[400]	[600]	[800]	[1000]	[1200]	[1400]	[1600]	[1800]	[1900]	[2350]
	<b>14</b>	<b>28</b>	<b>41</b>	<b>55</b>	<b>69</b>	<b>83</b>	<b>97</b>	<b>110</b>	<b>124</b>	<b>131</b>	<b>162</b>
[2]	219	481	731	975	1214	1437	1707	1726	1815	1925	
<b>7,6</b>	<b>51</b>	<b>48</b>	<b>45</b>	<b>41</b>	<b>36</b>	<b>30</b>	<b>24</b>	<b>20</b>	<b>12</b>	<b>1</b>	
[4]	228	493	750	1011	1263	1512	1770	1994	2223	2320	2659
<b>15,1</b>	<b>26</b>	<b>56</b>	<b>85</b>	<b>114</b>	<b>143</b>	<b>171</b>	<b>200</b>	<b>225</b>	<b>251</b>	<b>262</b>	<b>300</b>
[6]	214	474	730	994	1249	1502	1739	1989	2233	2347	2850
<b>22,7</b>	<b>24</b>	<b>54</b>	<b>82</b>	<b>112</b>	<b>141</b>	<b>170</b>	<b>196</b>	<b>225</b>	<b>252</b>	<b>265</b>	<b>322</b>
[8]	188	448	708	965	1224	1481	1688	1977	2220	2339	2870
<b>30,3</b>	<b>21</b>	<b>51</b>	<b>80</b>	<b>109</b>	<b>138</b>	<b>167</b>	<b>191</b>	<b>223</b>	<b>251</b>	<b>264</b>	<b>324</b>
[10]	156	416	674	934	1195	1449	1635	1947	2194	2316	2845
<b>37,9</b>	<b>18</b>	<b>47</b>	<b>76</b>	<b>106</b>	<b>135</b>	<b>164</b>	<b>185</b>	<b>220</b>	<b>248</b>	<b>262</b>	<b>321</b>
[12]	123	381	639	900	1157	1415	1576	1913	2160	2282	2818
<b>45,4</b>	<b>14</b>	<b>43</b>	<b>72</b>	<b>102</b>	<b>131</b>	<b>160</b>	<b>178</b>	<b>216</b>	<b>244</b>	<b>258</b>	<b>318</b>
[14]	82	339	600	855	1109	1371	1497	1874	2121	2246	2778
<b>53,0</b>	<b>9</b>	<b>38</b>	<b>68</b>	<b>97</b>	<b>125</b>	<b>155</b>	<b>169</b>	<b>212</b>	<b>240</b>	<b>254</b>	<b>314</b>
[15]	79	329	583	837	1094	1346	1465	1849	2100	2230	2758
<b>56,8</b>	<b>9</b>	<b>37</b>	<b>66</b>	<b>95</b>	<b>124</b>	<b>152</b>	<b>166</b>	<b>209</b>	<b>237</b>	<b>252</b>	<b>312</b>
[20]		185	439	694	947	1206	1214	1713	1961	2100	2631
<b>75,7</b>		<b>21</b>	<b>50</b>	<b>78</b>	<b>107</b>	<b>136</b>	<b>137</b>	<b>194</b>	<b>222</b>	<b>237</b>	<b>297</b>
		<b>523</b>	<b>521</b>	<b>518</b>	<b>513</b>	<b>508</b>	<b>502</b>	<b>495</b>	<b>486</b>	<b>475</b>	<b>450</b>

### S Motor 166 cm<sup>3</sup>/r [10.1 in<sup>3</sup>/r] Δ Pressure Bar [PSI]

	[200]	[400]	[600]	[800]	[1000]	[1200]	[1400]	[1600]	[1800]	[1900]	[2300]
	<b>14</b>	<b>28</b>	<b>41</b>	<b>55</b>	<b>69</b>	<b>83</b>	<b>97</b>	<b>110</b>	<b>124</b>	<b>131</b>	<b>159</b>
[2]	321	643	964	1256	1534	1800	1910	1970	2280	2261	
<b>7,6</b>	<b>36</b>	<b>73</b>	<b>109</b>	<b>142</b>	<b>173</b>	<b>203</b>	<b>216</b>	<b>223</b>	<b>258</b>	<b>255</b>	
[4]	321	643	964	1286	1607	1919	2159	2405	2629	2420	3049
<b>15,1</b>	<b>36</b>	<b>73</b>	<b>109</b>	<b>145</b>	<b>182</b>	<b>217</b>	<b>244</b>	<b>272</b>	<b>297</b>	<b>273</b>	<b>344</b>
[6]	321	643	964	1286	1555	1838	2125	2400	2656	2445	3187
<b>22,7</b>	<b>36</b>	<b>73</b>	<b>109</b>	<b>145</b>	<b>176</b>	<b>208</b>	<b>240</b>	<b>271</b>	<b>300</b>	<b>276</b>	<b>360</b>
[8]	711	892	1026	1222	1564	1907	2159	2398	2401	2448	3191
<b>30,3</b>	<b>80</b>	<b>101</b>	<b>116</b>	<b>138</b>	<b>177</b>	<b>215</b>	<b>244</b>	<b>271</b>	<b>271</b>	<b>277</b>	<b>360</b>
[10]	321	643	964	1260	1536	1862	2037	2333	2296	2413	3168
<b>37,9</b>	<b>36</b>	<b>73</b>	<b>109</b>	<b>142</b>	<b>174</b>	<b>210</b>	<b>230</b>	<b>264</b>	<b>259</b>	<b>273</b>	<b>358</b>
[12]	321	643	894	1198	1476	1813	2060	2353	2548	2662	3132
<b>45,4</b>	<b>36</b>	<b>73</b>	<b>101</b>	<b>135</b>	<b>167</b>	<b>205</b>	<b>233</b>	<b>266</b>	<b>288</b>	<b>301</b>	<b>354</b>
[14]	321	643	927	1190	1420	1752	2054	2326	2535	2305	3085
<b>53,0</b>	<b>36</b>	<b>73</b>	<b>105</b>	<b>134</b>	<b>160</b>	<b>198</b>	<b>232</b>	<b>263</b>	<b>286</b>	<b>260</b>	<b>349</b>
[15]	321	607	854	1112	1333	1675	2022	1950	2204	2268	3059
<b>56,8</b>	<b>36</b>	<b>69</b>	<b>96</b>	<b>126</b>	<b>151</b>	<b>189</b>	<b>228</b>	<b>220</b>	<b>249</b>	<b>256</b>	<b>346</b>
[20]		567	647	954	1239	1409	1740	1851	2072	2181	2911
<b>75,7</b>		<b>64</b>	<b>73</b>	<b>108</b>	<b>140</b>	<b>159</b>	<b>197</b>	<b>209</b>	<b>234</b>	<b>246</b>	<b>329</b>
		<b>457</b>	<b>457</b>	<b>457</b>	<b>457</b>	<b>457</b>	<b>451</b>	<b>442</b>	<b>425</b>	<b>410</b>	<b>394</b>

# S Series (103-)

## Performance Data

Motors run with high efficiency in all areas designated with a number for torque and speed, however for best motor life select a motor to run with a torque and speed range printed in the light shaded area.

Performance data is typical at 120 SUS. Actual data may vary slightly from unit to unit in production

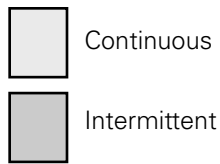

### S Motor 187 cm<sup>3</sup>/r [11.4 in<sup>3</sup>/r]

Δ Pressure Bar [PSI]

	[200]	[400]	[600]	[800]	[1000]	[1200]	[1400]	[1600]	[1800]	[1850]	[2250]
	<b>14</b>	<b>28</b>	<b>41</b>	<b>55</b>	<b>69</b>	<b>83</b>	<b>97</b>	<b>110</b>	<b>124</b>	<b>128</b>	<b>155</b>
[2]	282	626	950	1267	1582	1879	2217	2407	2591	2541	
	32	71	107	143	179	212	250	272	293	287	
<b>7,6</b>	<b>39</b>	<b>38</b>	<b>36</b>	<b>34</b>	<b>31</b>	<b>27</b>	<b>24</b>	<b>18</b>	<b>11</b>	<b>4</b>	
[4]	304	642	979	1311	1640	1961	2295	2588	2891	2938	3463
	34	73	111	148	185	222	259	292	327	332	391
<b>15,1</b>	<b>80</b>	<b>78</b>	<b>76</b>	<b>74</b>	<b>71</b>	<b>67</b>	<b>63</b>	<b>58</b>	<b>52</b>	<b>44</b>	<b>32</b>
[6]	288	624	959	1294	1625	1949	2264	2584	2889	2950	3533
	33	71	108	146	184	220	256	292	326	333	399
<b>22,7</b>	<b>120</b>	<b>119</b>	<b>117</b>	<b>114</b>	<b>111</b>	<b>107</b>	<b>102</b>	<b>96</b>	<b>90</b>	<b>82</b>	<b>68</b>
[8]	255	591	923	1256	1584	1905	2199	2536	2843	2912	3515
	29	67	104	142	179	215	248	286	321	329	397
<b>30,3</b>	<b>162</b>	<b>160</b>	<b>158</b>	<b>155</b>	<b>152</b>	<b>147</b>	<b>142</b>	<b>135</b>	<b>127</b>	<b>119</b>	<b>104</b>
[10]	218	553	882	1216	1546	1872	2128	2503	2809	2874	3468
	25	62	100	137	175	212	240	283	317	325	392
<b>37,9</b>	<b>203</b>	<b>201</b>	<b>199</b>	<b>196</b>	<b>193</b>	<b>189</b>	<b>183</b>	<b>177</b>	<b>169</b>	<b>160</b>	<b>145</b>
[12]	169	507	837	1165	1491	1817	2039	2431	2736	2802	3390
	19	57	95	132	169	205	230	275	309	317	383
<b>45,4</b>	<b>243</b>	<b>242</b>	<b>240</b>	<b>238</b>	<b>234</b>	<b>231</b>	<b>225</b>	<b>219</b>	<b>212</b>	<b>203</b>	<b>187</b>
[14]	119	455	780	1110	1432	1743	1942	2353	2659	2733	3323
	13	51	88	125	162	197	219	266	300	309	375
<b>53,0</b>	<b>284</b>	<b>283</b>	<b>281</b>	<b>279</b>	<b>276</b>	<b>272</b>	<b>267</b>	<b>261</b>	<b>254</b>	<b>245</b>	<b>229</b>
[15]	105	434	761	1088	1404	1720	1904	2313	2605	2692	3267
	12	49	86	123	159	194	215	261	294	304	369
<b>56,8</b>	<b>304</b>	<b>304</b>	<b>302</b>	<b>299</b>	<b>296</b>	<b>293</b>	<b>288</b>	<b>281</b>	<b>274</b>	<b>266</b>	<b>250</b>
[20]		250	578	909	1230	1548	1590	2178	2470	2548	3122
		28	65	103	139	175	180	246	279	288	353
<b>75,7</b>		<b>405</b>	<b>405</b>	<b>403</b>	<b>400</b>	<b>397</b>	<b>393</b>	<b>386</b>	<b>379</b>	<b>369</b>	<b>354</b>

### S Motor 225 cm<sup>3</sup>/r [13.7 in<sup>3</sup>/r]

Δ Pressure Bar [PSI]

	[200]	[400]	[600]	[800]	[1000]	[1200]	[1400]	[1600]	[1700]	[2050]
	<b>14</b>	<b>28</b>	<b>41</b>	<b>55</b>	<b>69</b>	<b>83</b>	<b>97</b>	<b>110</b>	<b>117</b>	<b>138</b>
[2]	436	842	1156	1592	1884	2251	2787	2846	2845	3359
	49	95	131	180	213	254	315	322	321	379
<b>7,6</b>	<b>32</b>	<b>30</b>	<b>29</b>	<b>26</b>	<b>23</b>	<b>19</b>	<b>16</b>	<b>13</b>	<b>6</b>	<b>2</b>
[4]	554	871	1265	1710	2103	2421	2992	3069	3267	3843
	63	98	143	193	238	274	338	347	369	434
<b>15,1</b>	<b>66</b>	<b>65</b>	<b>63</b>	<b>60</b>	<b>57</b>	<b>54</b>	<b>49</b>	<b>44</b>	<b>38</b>	<b>32</b>
[6]	410	827	1253	1670	2079	2427	2923	3049	3214	3838
	46	93	142	189	235	274	330	344	363	434
<b>22,7</b>	<b>100</b>	<b>99</b>	<b>96</b>	<b>94</b>	<b>91</b>	<b>87</b>	<b>83</b>	<b>77</b>	<b>71</b>	<b>63</b>
[8]	382	853	1292	1724	2131	2433	3017	3155	3290	3835
	43	96	146	195	241	275	341	356	372	433
<b>30,3</b>	<b>134</b>	<b>133</b>	<b>131</b>	<b>128</b>	<b>125</b>	<b>121</b>	<b>116</b>	<b>109</b>	<b>101</b>	<b>94</b>
[10]	436	843	1092	1471	1841	2229	2574	2983	3164	3769
	49	95	123	166	208	252	291	337	358	426
<b>37,9</b>	<b>168</b>	<b>167</b>	<b>166</b>	<b>164</b>	<b>161</b>	<b>157</b>	<b>151</b>	<b>144</b>	<b>135</b>	<b>125</b>
[12]	382	778	1151	1540	1874	2256	2694	2991	3158	3764
	43	88	130	174	212	255	304	338	357	425
<b>45,4</b>	<b>202</b>	<b>201</b>	<b>200</b>	<b>197</b>	<b>194</b>	<b>190</b>	<b>185</b>	<b>178</b>	<b>168</b>	<b>159</b>
[14]	234	646	1059	1471	1899	2250	2575	2951	3165	3777
	26	73	120	166	215	254	291	333	358	427
<b>53,0</b>	<b>236</b>	<b>236</b>	<b>234</b>	<b>232</b>	<b>229</b>	<b>225</b>	<b>220</b>	<b>213</b>	<b>203</b>	<b>192</b>
[15]	287	674	1018	1408	1807	2142	2464	2832	3029	3606
	32	76	115	159	204	242	278	320	342	407
<b>56,8</b>	<b>253</b>	<b>253</b>	<b>252</b>	<b>249</b>	<b>246</b>	<b>242</b>	<b>237</b>	<b>232</b>	<b>222</b>	<b>213</b>
[20]		418	797	1173	1604	1917	2053	2620	2808	3405
		47	90	133	181	217	232	296	317	385
<b>75,7</b>		<b>337</b>	<b>337</b>	<b>336</b>	<b>333</b>	<b>329</b>	<b>325</b>	<b>320</b>	<b>312</b>	<b>303</b>

# S Series (103-)

## Performance Data

Motors run with high efficiency in all areas designated with a number for torque and speed, however for best motor life select a motor to run with a torque and speed range printed in the light shaded area.

Performance data is typical at 120 SUS. Actual data may vary slightly from unit to unit in production

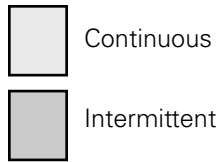

**S Motor 298 cm<sup>3</sup>/r [18.2 in<sup>3</sup>/r]**  
 $\Delta$  Pressure Bar [PSI]

	[200]	[400]	[600]	[800]	[1000]	[1200]	[1400]	[1500]	[1800]
	<b>14</b>	<b>28</b>	<b>41</b>	<b>55</b>	<b>69</b>	<b>83</b>	<b>97</b>	<b>103</b>	<b>124</b>
[2]	529	1069	1711	2210	2515	2924	3867	4143	3843
<b>7,6</b>	<b>60</b>	<b>121</b>	<b>193</b>	<b>250</b>	<b>284</b>	<b>330</b>	<b>437</b>	<b>468</b>	<b>434</b>
[4]	579	1159	1738	2317	2897	3230	4055	4345	4441
<b>15,1</b>	<b>65</b>	<b>131</b>	<b>196</b>	<b>262</b>	<b>327</b>	<b>365</b>	<b>458</b>	<b>491</b>	<b>502</b>
[6]	507	1159	1738	2170	2694	3050	3798	4070	4467
<b>22,7</b>	<b>57</b>	<b>131</b>	<b>196</b>	<b>245</b>	<b>304</b>	<b>345</b>	<b>429</b>	<b>460</b>	<b>505</b>
[8]	567	1158	1721	2144	2516	2994	3752	4020	4424
<b>30,3</b>	<b>64</b>	<b>131</b>	<b>194</b>	<b>242</b>	<b>284</b>	<b>338</b>	<b>424</b>	<b>454</b>	<b>500</b>
[10]	494	1067	1621	2109	2539	3086	3691	3955	4442
<b>37,9</b>	<b>56</b>	<b>121</b>	<b>183</b>	<b>238</b>	<b>287</b>	<b>349</b>	<b>417</b>	<b>447</b>	<b>502</b>
[12]	471	1075	1588	2209	2577	3075	3866	4142	4323
<b>45,4</b>	<b>53</b>	<b>121</b>	<b>179</b>	<b>250</b>	<b>291</b>	<b>347</b>	<b>437</b>	<b>468</b>	<b>488</b>
[14]	334	947	1463	2096	2485	2968	3668	3930	4190
<b>53,0</b>	<b>38</b>	<b>107</b>	<b>165</b>	<b>237</b>	<b>281</b>	<b>335</b>	<b>414</b>	<b>444</b>	<b>473</b>
[15]	329	930	1446	1990	2434	2780	3482	3731	4122
<b>56,8</b>	<b>37</b>	<b>105</b>	<b>163</b>	<b>225</b>	<b>275</b>	<b>314</b>	<b>393</b>	<b>421</b>	<b>466</b>
[20]		598	1113	1650	2169	2533	2888	3094	3890
<b>75,7</b>		<b>68</b>	<b>126</b>	<b>186</b>	<b>245</b>	<b>286</b>	<b>326</b>	<b>350</b>	<b>439</b>
		<b>254</b>	<b>254</b>	<b>252</b>	<b>250</b>	<b>248</b>	<b>244</b>	<b>244</b>	<b>232</b>

**S Motor 372 cm<sup>3</sup>/r [22.7 in<sup>3</sup>/r]**  
 $\Delta$  Pressure Bar [PSI]

	[200]	[400]	[600]	[800]	[1000]	[1200]	[1300]	[1500]
	<b>14</b>	<b>28</b>	<b>41</b>	<b>55</b>	<b>69</b>	<b>83</b>	<b>90</b>	<b>103</b>
[2]	723	1445	2168	2822	3447	4045	4383	4599
<b>7,6</b>	<b>82</b>	<b>163</b>	<b>245</b>	<b>319</b>	<b>390</b>	<b>457</b>	<b>495</b>	<b>520</b>
[4]	723	1445	2168	2890	3613	4312	4672	5200
<b>15,1</b>	<b>82</b>	<b>163</b>	<b>245</b>	<b>327</b>	<b>408</b>	<b>487</b>	<b>528</b>	<b>587</b>
[6]	723	1445	2168	2890	3494	4131	4475	5117
<b>22,7</b>	<b>82</b>	<b>163</b>	<b>245</b>	<b>327</b>	<b>395</b>	<b>467</b>	<b>506</b>	<b>578</b>
[8]	723	1445	2168	2746	3516	4286	4643	5199
<b>30,3</b>	<b>82</b>	<b>163</b>	<b>245</b>	<b>310</b>	<b>397</b>	<b>484</b>	<b>525</b>	<b>587</b>
[10]	723	1445	2168	2831	3453	4184	4532	4906
<b>37,9</b>	<b>82</b>	<b>163</b>	<b>245</b>	<b>320</b>	<b>390</b>	<b>473</b>	<b>512</b>	<b>554</b>
[12]	723	1445	2008	2692	3316	4075	4414	4961
<b>45,4</b>	<b>82</b>	<b>163</b>	<b>227</b>	<b>304</b>	<b>375</b>	<b>460</b>	<b>499</b>	<b>561</b>
[14]	723	1445	2084	2675	3192	3938	4266	4946
<b>53,0</b>	<b>82</b>	<b>163</b>	<b>235</b>	<b>302</b>	<b>361</b>	<b>445</b>	<b>482</b>	<b>559</b>
[15]	723	1365	1918	2499	2996	3766	4079	4870
<b>56,8</b>	<b>82</b>	<b>154</b>	<b>217</b>	<b>282</b>	<b>338</b>	<b>425</b>	<b>461</b>	<b>550</b>
[20]		1274	1454	2144	2784	3167	3431	4191
<b>75,7</b>		<b>144</b>	<b>164</b>	<b>242</b>	<b>315</b>	<b>358</b>	<b>388</b>	<b>474</b>
		<b>204</b>	<b>204</b>	<b>204</b>	<b>204</b>	<b>203</b>	<b>203</b>	<b>201</b>

# S Series (103-)

## Dimensions

(Refer to pages B-4-19 thru B-4-22 for shaft and port dimensions.)

## Ports

7/8-14 SAE O-Ring

6-1/2 (BSP) Straight thread manifold

## Standard Rotation Viewed from Shaft End

Port A Pressurized — CW

Port B Pressurized — CCW

### 2 Bolt Flange

82,55/82,42  
[3.250/3.245]  
Pilot Dia.

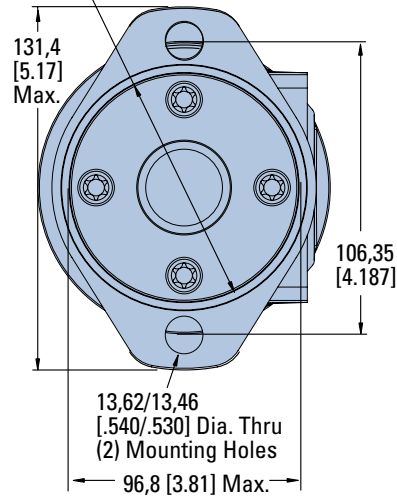

Groove Provided for 82,6 [3.25] I.D. x 2,62 [1.103] Cross Section O-ring ( Dash No. 152)

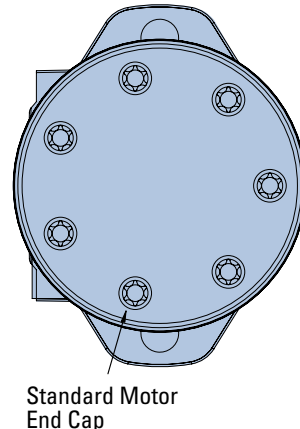
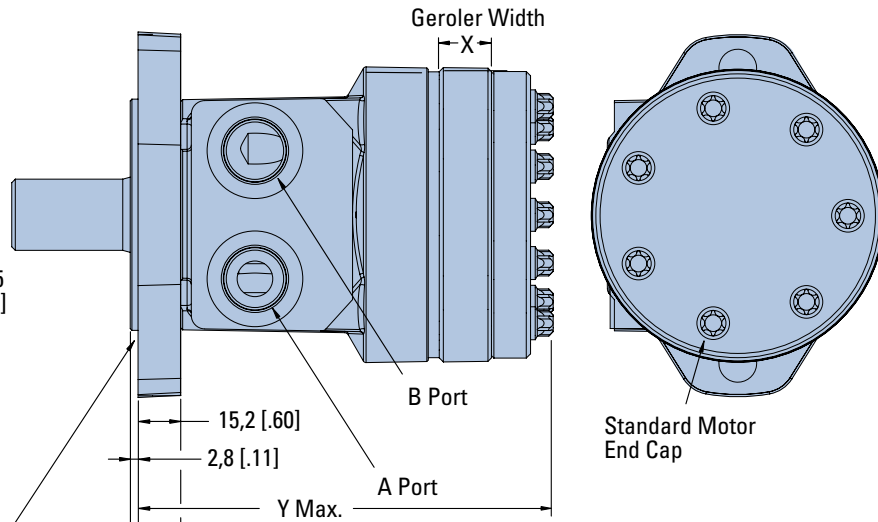

### 4 Bolt Flange

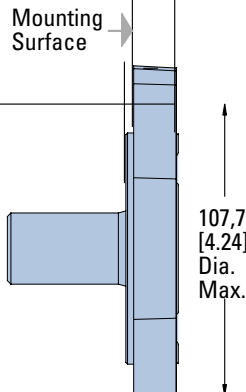
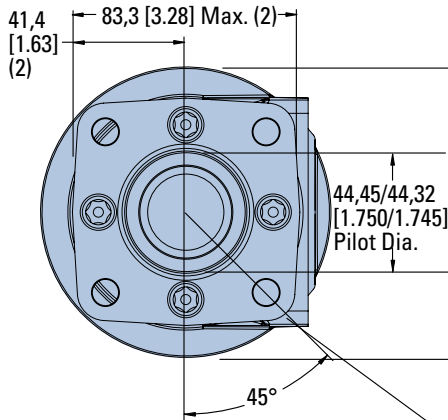

Displacement cm <sup>3</sup> /r [in <sup>3</sup> /r]	X mm [inch]	Y mm [inch]
58 [3.6]	7,5 [.30]	138,0 [5.43]
76 [4.6]	9,8 [.39]	140,3 [5.52]
93 [5.7]	12,0 [.47]	142,5 [5.61]
120 [7.3]	15,5 [.61]	146,0 [5.75]
144 [8.8]	18,6 [.73]	149,1 [5.87]
165 [10.1]	21,3 [.84]	151,8 [5.98]
186 [11.4]	24,0 [.94]	154,5 [6.08]
225 [13.7]	28,9 [1.14]	159,4 [6.28]
299 [18.2]	38,5 [1.52]	169,0 [6.66]
371 [22.7]	47,9 [1.88]	178,4 [7.02]

3/8-16 UNC (15,2 [.60] Max. Bolt Thread Engagement) Mounting Holes (4) Equally Spaced on 82,6 [3.25] Dia. Bolt Circle or  
M10 x 1,5 (15,2 [.60] Max. Bolt Thread Engagement) Mounting Holes (4) Equally Spaced on 82,6 [3.25] Dia. Bolt Circle

# S Series (103-)

## Product Numbers

Use three-digit prefix (103-) plus four-digit number from charts for complete product number (ex: 103-1093). Orders will not be accepted without the three-digit prefix.

### 2 Bolt Flange

SHAFT	PORT SIZE	DISPL. cm <sup>3</sup> /r [in <sup>3</sup> /r] / PRODUCT NUMBER									
		59 [ 3.6]	75 [ 4.6]	93 [ 5.7]	120 [ 7.3]	144 [ 8.8]	166 [ 10.1]	187 [11.4]	225 [13.7]	298 [18.2]	372 [22.7]
1 in. Straight w/Woodruff Key	7/8-14 O-ring	103-1537	-1034	-1035	-1538	-1539	-1036	-1037	-1038	-1039	-1040
	1/2 NPTF	103-1540	-1026	-1027	-1541	-1542	-1028	-1029	-1030	-1031	-1032
	Manifold	103-1543	-1042	-1043	-1544	-1545	-1044	-1045	-1046	-1047	-1048
1 in. SAE 6B Splined	7/8-14 O-ring	103-1552	-1082	-1083	-1553	-1554	-1084	-1085	-1086	-1087	-1088
	1/2 NPTF	103-1555	-1074	-1075	-1556	-1557	-1076	-1077	-1078	-1079	-1080
	Manifold	103-1558	-1090	-1091	-1559	-1560	-1092	-1093	-1094	-1095	-1096

103-1093

### 4 Bolt Flange

SHAFT	PORT SIZE	DISPL. cm <sup>3</sup> /r [in <sup>3</sup> /r] / PRODUCT NUMBER									
		59 [ 3.6]	75 [ 4.6]	93 [ 5.7]	120 [ 7.3]	144 [ 8.8]	166 [ 10.1]	187 [11.4]	225 [13.7]	298 [18.2]	372 [22.7]
1 in. Straight w/Woodruff Key	7/8-14 O-ring	103-1570	-1010	-1011	-1571	-1572	-1012	-1013	-1014	-1015	-1016
	1/2 NPTF	103-1573	-1002	-1003	-1574	-1575	-1004	-1005	-1006	-1007	-1008
	Manifold	103-1576	-1018	-1019	-1577	-1578	-1020	-1021	-1022	-1023	-1024
1 in. SAE 6BSplined	7/8-14 O-ring	103-1579	-1058	-1059	-1580	-1581	-1060	-1061	-1062	-1063	-1064
	1/2 NPTF	103-1582	-1050	-1051	-1583	-1584	-1052	-1053	-1054	-1055	-1056
	Manifold	103-1585	-1066	-1067	-1586	-1587	-1068	-1069	-1070	-1071	-1072

103-1069

### S Series Motors with Corrosion Protection

SHAFT	MOUNTING	PORT SIZE	DISPL. cm <sup>3</sup> /r [in <sup>3</sup> /r] / PRODUCT NUMBER									
			59 [ 3.6]	75 [ 4.6]	93 [ 5.7]	120 [ 7.3]	144 [ 8.8]	166 [ 10.1]	187 [11.4]	225 [13.7]	298 [18.2]	372 [22.7]
1 in. Straight w/Woodruff Key	2 Bolt Flange	7/8-14 O-ring	103-1645	-	-	-	-	-	-	-1649	-	-1650
	4 Bolt Flange	1/2 NPTF	-	-	-	-	-	-	-	-1620	-	-1621

\*Manifold product numbers shown are for motors with four 5/16 z-18 port face mounting threads. Manifold, manifold mounting o-rings and bolts are NOT included.

For S Series Motors with a configuration Not Shown in the charts above: Use the model code number system on page B-3-11 to specify the product in detail.

# Product Numbers

## S Series with Low Speed Valving

Motors with the low speed valving option enable very smooth low speed operation while maintaining high torque.

Designed to run continuously at up to 200 RPM at standard rated pressures and reduced flows, this option provides smooth operation at low speeds. Furthermore, they resist slippage and have

more momentary load holding ability than the standard H and S Series motors. Motors with this valving are not intended for low pressure applications (41 Bar [600 PSI] Minimum). Shaft side / radial load ratings are not affected by this valving.

Use digit prefix—103- plus four digit number from charts for complete product number—Example: 103-2678.

**Orders will not be accepted without the three-digit prefix.**

### 2 Bolt Flange

SHAFT	PORT SIZE	DISPL. cm <sup>3</sup> /r [in <sup>3</sup> /r] / PRODUCT NUMBER									
		59 [ 3.6]	75 [ 4.6]	93 [ 5.7]	120 [ 7.3]	144 [ 8.8]	166 [ 10.1]	187 [11.4]	225 [13.7]	298 [18.2]	372 [22.7]
1 in. Straight w/Woodruff Key	7/8 -14 O-ring	103- —	-1427	-1428	—	—	-1429	-1430	-1431	-1432	-1433
	1/2 NPTF	103- —	-1419	-1420	—	—	-1421	-1422	-1423	-1424	-1425
	Manifold*	103- —	—	—	—	—	—	—	—	—	—
1 in. SAE 6B Splined	7/8 -14 O-ring	103- —	-1525	—	—	-2692	—	—	-1675	—	—
	1/2 NPTF	103- —	—	-1634	—	—	—	—	—	—	—
	Manifold*	103- —	-1522	-2678	—	—	—	—	—	—	-1527

### 4 Bolt Flange

SHAFT	PORT SIZE	DISPL. cm <sup>3</sup> /r [in <sup>3</sup> /r] / PRODUCT NUMBER									
		59 [ 3.6]	75 [ 4.6]	93 [ 5.7]	120 [ 7.3]	144 [ 8.8]	166 [ 10.1]	187 [11.4]	225 [13.7]	298 [18.2]	372 [22.7]
1 in. Straight w/Woodruff Key	7/8 -14 O-ring	103-1625	-1410	-1411	-1626	-2531	-1412	-1413	-1414	-1415	-1416
	1/2 NPTF	103-1644	-1402	-1403	—	—	-1404	-1405	-1406	-1407	-1408

103-1404

103-1527

\*Manifold product numbers shown are for motors with four 5/16 -18 port face mounting threads. Manifold, manifold mounting O-rings and bolts are NOT included.

For S Series Motors with Low Speed Valving Not Shown in the chart above: Use the model code number system on page B-3-11 to specify the product in detail.

# S Series (103-)

## Model Code

The following 16-digit coding system has been developed to identify all of the configuration options for the S motor. Use this model code to specify a motor with the desired features. All 16-digits of the code must be present when ordering. You may want to photocopy the matrix below to ensure that each number is entered in the correct box.

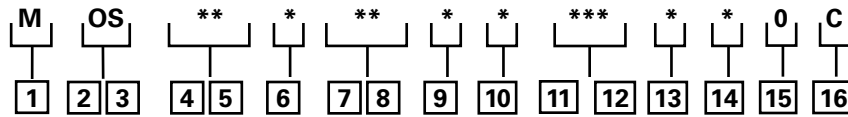

### **1** Product

**M** – S Motor

### **2, 3** Product Series

**OS** – S Series

### **4, 5** Displacement cm<sup>3</sup>/r [in<sup>3</sup>/r]

- 04** – 59 [ 3.6]
- 05** – 74 [ 4.5]
- 06** – 97 [ 5.9]
- 07** – 120 [ 7.3]
- 09** – 146 [ 8.9]
- 10** – 159 [ 9.7]
- 11** – 185 [11.3]
- 10** – 159 [ 9.7]
- 14** – 231 [14.1]
- 18** – 293 [17.9]
- 23** – 370 [22.6]

### **6** Mounting Type

- A** – 2 Bolt (Standard) 82,6 [3.25] Pilot Dia. and 13,59 [.535] Dia. Mounting Holes 106,2 [4.18] Dia. B.C.
- B** – 4 Bolt (Standard) 44,4 [1.75] Pilot Dia. and 3/8-16 Mounting Holes 82,6 [3.25] Dia. B.C.
- E** – 4 Bolt (Standard) 44,4 [1.75] Pilot Dia. and M10 x 1,5 Mounting Holes 82,6 [3.25] Dia. B.C.

**H** – 2 Bolt (Std.) 101,6 [4.00] Pilot Dia. and 14,35 [.565] Dia. Mounting Holes 146,0 [5.75] Dia. B.C. (SAE B)

**K** – 4 Bolt Magneto 82,6 [3.25] Pilot Dia. and 13,59 [.535] Dia. Mounting Holes 106,2 [4.18] Dia. B.C.

### **7, 8** Output Shaft

- 01** – 1 inch Dia. Straight with Woodruff Key and 1/4 -20 Threaded Hole
- 02** – 1 inch Dia. SAE 6B Splined with 1/4 -20 Threaded Hole
- 07** – 1 inch Dia. Straight with 7,9 [.31] Dia. Crosshole 11,2 [.44] from End
- 08** – 1 inch Dia. Straight with 10,2 [.40] Dia. Crosshole 15,7 [.62] from End and 1/4 -20 Threaded Hole
- 16** – 7/8 inch Dia. SAE B 13T Splined
- 17** – 7/8 inch Dia. SAE B Straight with Square Key
- 18** – 1 inch Dia. Tapered with Woodruff Key and Nut
- 24** – 25mm Dia. Straight with 8mm Key and 8mm x 1.2 Threaded Hole
- 27** – 1 inch Dia. Straight with Woodruff Key and 1/4 -20 threaded Hole (Coated for Corrosion Protection)

### **9** Ports

- A** – 7/8 -14 O-ring
- B** – 1/2 -14 NPTF
- C** – Manifold (5/16-18 Mounting Threads)
- D** – Manifold (M8 x 1,25 Mounting Threads)
- E** – G 1/2 (BSP) End Cap

### **10** Case Flow Options

- 0** – No Case Drain
- 1** – 7/16 -20 O-ring Port End Cap
- 2** – G 1/4 (BSP) End Cap

### **11, 12** Special Features (Hardware)

- 00** – None
- AB** – Low Speed Valve
- AC** – Viton Shaft Seal
- BZ** – Speed Sensor
- DS** – High Pressure Shaft Seal

### **13** Special Features (Assembly)

- 0** – None
- 1** – Reverse Rotation
- 2** – Flange Rotated 90°

### **14** Paint/ Special Packaging

- 0** – No Paint, Individual Box
- A** – Painted Low Gloss Black, Individual Box
- B** – No Paint, Bulk Box Option
- C** – Painted Low Gloss Black, Bulk Box Option

### **15** Eaton Assigned Code when Applicable

- 0** – Assigned Code

### **16** Eaton Assigned Design Code

- C** – Assigned Design Code

# Notes



# T Series (158-)

## Highlights

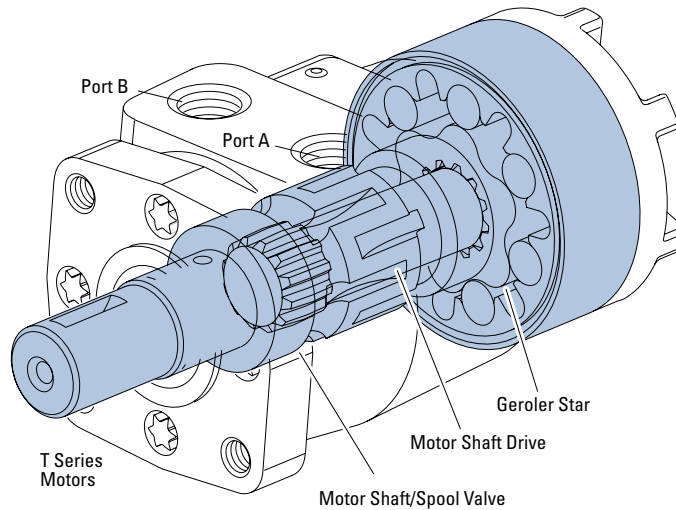

### Features:

- Constant clearance Geroler, geometry
- Optimized drive system with reduced running angle
- Three-pressure zone design (ability to reduce case pressure)
- Variety of displacements, shafts and mounts
- Special options to meet customer needs

### Benefits:

- High efficiency
- Smooth low-speed operation
- Extended motor life (especially at low speed conditions)
- Design flexibility
- Ability to optimize designs for your application needs
- Extends leak-free performance

### Applications:

- Agricultural augers, harvesters, seeders
- Car wash brushes
- Food processing
- Railroad maintenance equipment
- Machine tools
- Conveyors
- Industrial sweepers and floor polishers
- Saw mill works
- Turf equipment
- Concrete and asphalt equipment
- Skid steer attachments
- Many more

### Description

The newest Geroler motor, the "T Series," features the latest innovations in Geroler technology. These innovations include optimized Geroler geometry with lower drive running angle for improved life and improved low speed performance. In addition, the improved housing and smaller diameter end cap results in increased envelope rigidity which improves efficiency under high pressure loads. All of these innovations come together to make the T Series motor the highest performing motor in its class.

### Specifications for T Series Motors

Geroler Element	11 Displacements
Flow l/min [GPM]	55 [15] Continuous*** 75 [20] Intermittent**
Speed	Up to 1021 RPM
Pressure bar [PSI]	155 [2250] Cont.*** 190 [2750] Inter.**
Torque Nm [lb-in]	441 [3905] Cont.*** 486 [4300] Inter.**

\*\*\* Continuous— (Cont.) Continuous rating, motor may be run continuously at these ratings.

\*\* Intermittent— (Inter.) Intermittent operation, 10% of every minute.



Crane (winch)



Paving



Harvester



Crane and winches

# T Series (158-)

## Specifications

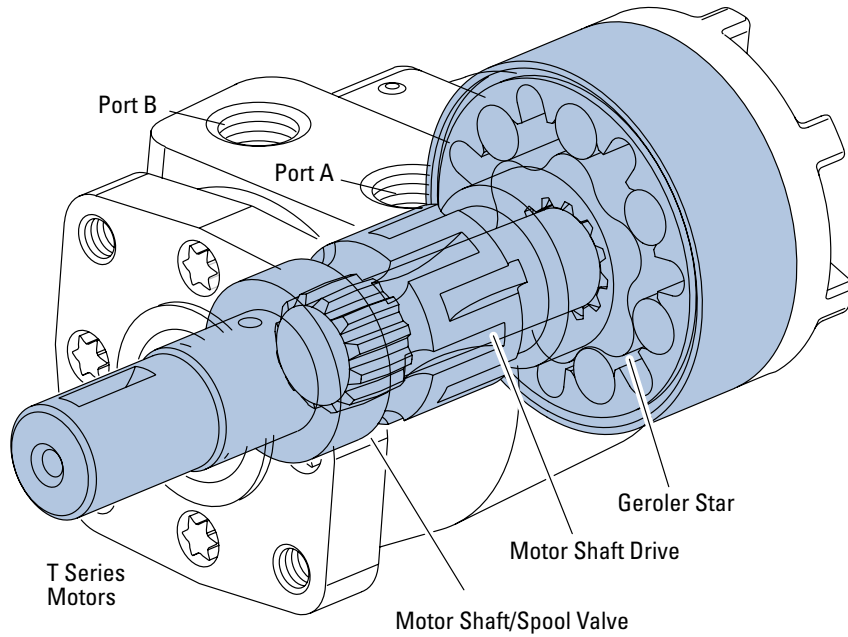

### SPECIFICATION DATA — T MOTORS

Displ. cm <sup>3</sup> /r [in <sup>3</sup> /r]		36 [2.2]	49 [3.0]	66 [4.0]	80 [4.9]	102 [6.2]	131 [8.0]	157 [9.6]	195 [11.9]	244 [14.9]	306 [18.7]	370 [22.6]
Max. Speed (RPM) @ Continuous Flow		1021	906	849	694	550	426	355	287	229	183	152
Flow LPM [GPM]	Continuous	38 [10]	45 [12]	57 [15]	57 [15]	57 [15]	57 [15]	57 [15]	57 [15]	57 [15]	57 [15]	57 [15]
	Intermittent	38 [10]	57 [15]	68 [18]	76 [20]	76 [20]	76 [20]	76 [20]	76 [20]	76 [20]	76 [20]	76 [20]
Torque Nm [lb-in]	Continuous	76	105	138	174	219	251	297	359	410	441	430
	Intermittent **	[672]	[928]	[1222]	[1541]	[1936]	[2226]	[2628]	[3178]	[3633]	[3905]	[3811]
		93	118	168	212	264	307	359	437	485	483	486
		[824]	[1131]	[1488]	[1872]	[2339]	[2718]	[3178]	[3864]	[4290]	[4275]	[4300]
Pressure Δ Bar Δ PSI]	Continuous*	155	155	155	155	155	138	138	138	127	110	90
	Intermittent**	[2250]	[2250]	[2250]	[2250]	[2250]	[2000]	[2000]	[2000]	[1850]	[1600]	[1300]
		190	190	190	190	190	172	172	172	155	124	103
		[2750]	[2750]	[2750]	[2750]	[2750]	[2500]	[2500]	[2500]	[2250]	[1800]	[1500]

A simultaneous maximum torque and maximum speed NOT recommended.

#### Note:

To assure best motor life, run motor for approximately one hour at 30% of rated pressure before application to full load. Be sure motor is filled with fluid prior to any load applications.

#### Maximum Inlet Pressure:

172 Bar [2500 PSI] without regard to Δ Bar [D PSI] and/or back pressure ratings or combination thereof.

6B splined or Tapered shafts are recommended whenever operation above 282 NM [2500 lb-in] of torque, especially for those applications subject to frequent reversals.

#### Δ Pressure:

The true Δ bar [Δ PSI] between inlet port and outlet port

#### Continuous Rating:

Motor may be run continuously at these ratings

#### Intermittent Operation:

10% of every minute

#### Recommended Fluids:

Premium quality, anti-wear type hydraulic oil with a viscosity of not less than 70 SUS at operating temperature.

#### Recommended Maximum System Operating Temp.:

82°C [180°F]

#### Recommended Filtration:

per ISO Cleanliness Code 4406, level 20/18/13

# T Series (158-, 185-)

## Performance Data

Motors run with high efficiency in all areas designated with a number for torque and speed. For best motor life select a motor to run with a torque and speed range shown in the light shaded area.

Performance data is typical at 120 SUS. Actual data may vary slightly from unit to unit in production.

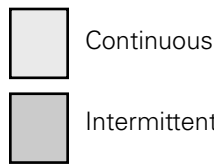

**36 cm<sup>3</sup>/r [2.2 in<sup>3</sup>/r]**  
Δ Pressure Bar [PSI]  
Continuous

	[200] 14	[400] 28	[600] 41	[800] 55	[1000] 69	[1200] 83	[1400] 97	[1600] 110	[1800] 124	[2000] 138	[2200] 152	[2250] 155	Max. Contin- uous	Max. Inter- mittent
[2] 7,6	[50] 6 209	[110] 12 203	[172] 19 197	[233] 26 191	[291] 33 189	[348] 39 181	[401] 45 167	[455] 51 164	[501] 57 153	[546] 62 139	[590] 67 122	[596] 67 116	[635] 72 64	
[4] 15,1	[50] 6 415	[109] 12 411	[172] 19 398	[233] 26 388	[296] 33 384	[355] 40 381	[414] 47 368	[475] 54 357	[534] 60 354	[584] 66 323	[646] 73 304	[659] 74 302	[786] 89 283	
[6] 22,7	[43] 5 617	[108] 12 613	[171] 19 602	[233] 26 595	[298] 34 585	[361] 41 570	[420] 47 563	[479] 54 558	[538] 61 534	[595] 67 520	[657] 74 504	[672] 76 496	[824] 93 425	
[8] 30,3	[39] 4 821	[101] 11 815	[164] 19 803	[226] 26 797	[292] 33 784	[354] 40 774	[415] 47 758	[475] 54 747	[538] 61 732	[592] 67 707	[656] 74 688	[670] 76 680	[819] 92 607	
Max. contin- uous 37,9	[30] 3 1021	[93] 11 1014	[155] 18 1002	[214] 24 999	[278] 31 981	[342] 39 965	[406] 46 953	[473] 53 937	[532] 60 921	[590] 67 903	[650] 73 880	[668] 75 873	[805] 91 799	



**49 cm<sup>3</sup>/r [3.0 in<sup>3</sup>/r]**  
Δ Pressure Bar [PSI]  
Continuous

	[200] 14	[400] 28	[600] 41	[800] 55	[1000] 69	[1200] 83	[1400] 97	[1600] 110	[1800] 124	[2000] 138	[2200] 152	[2250] 155	Max. Contin- uous	Max. Inter- mittent
[2] 7,6	[73] 8 152	[161] 18 152	[245] 28 148	[327] 37 147	[408] 46 142	[486] 55 141	[563] 64 134	[641] 72 124	[710] 80 115	[786] 89 109	[849] 96 95	[866] 98 92	[1023] 116 58	
[4] 15,1	[72] 8 303	[160] 18 298	[246] 28 294	[329] 37 290	[416] 47 276	[500] 56 273	[584] 66 265	[668] 75 261	[746] 84 245	[825] 93 243	[901] 102 235	[922] 104 228	[1123] 127 152	
[6] 22,7	[58] 7 461	[148] 17 450	[234] 26 445	[326] 37 438	[413] 47 434	[500] 56 421	[583] 66 419	[663] 75 410	[746] 84 407	[827] 93 389	[909] 103 376	[928] 105 373	[1131] 128 344	
[8] 30,3	[44] 5 607	[127] 14 603	[216] 24 600	[306] 35 590	[392] 44 583	[480] 54 576	[566] 64 564	[652] 74 554	[734] 83 545	[815] 92 536	[897] 101 522	[917] 104 520	[1125] 127 503	
[10] 37,9	[39] 4 755	[128] 14 750	[213] 24 745	[302] 34 738	[391] 44 732	[477] 54 719	[562] 63 713	[647] 73 702	[731] 83 696	[815] 92 682	[897] 101 663	[917] 104 661	[1121] 127 638	
Max. contin- uous 45,4	[33] 4 906	[119] 13 902	[203] 23 895	[291] 33 883	[378] 43 875	[464] 52 862	[551] 62 859	[635] 72 844	[719] 81 835	[802] 91 819	[883] 100 806	[900] 102 804	[1061] 120 788	
Max. Inter- mittent 56,8	[26] 3 1132	[86] 10 1124	[172] 19 1113	[256] 29 1115	[342] 39 1106	[430] 49 1106	[505] 57 1098	[591] 67 1093	[674] 76 1079	[745] 84 1070	[830] 94 1058	[851] 96 1056		

# T Series (158-, 185-)

## Performance Data

Motors run with high efficiency in all areas designated with a number for torque and speed. For best motor life select a motor to run with a torque and speed range shown in the light shaded area.

Performance data is typical at 120 SUS. Actual data may vary slightly from unit to unit in production.

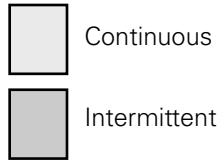

**66 cm<sup>3</sup>/r [4.0 in<sup>3</sup>/r]**  
□ Pressure Bar [PSI]  
Continuous

		[200]	[400]	[600]	[800]	[1000]	[1200]	[1400]	[1600]	[1800]	[2000]	[2200]	[2250]	[2750]
		14	28	41	55	69	83	97	110	124	138	152	155	190
Flow LPM [GPM]	[2]	[78] 9 114	[191] 22 111	[303] 34 110	[414] 47 107	[522] 59 105	[625] 71 101	[706] 80 96	[804] 91 92	[898] 101 87	[991] 112 81	[1081] 122 73	[1103] 125 72	[1318] 149 48
	7,6	[97] 11 229	[209] 24 229	[325] 37 217	[441] 50 216	[548] 62 212	[657] 74 205	[766] 87 194	[873] 99 190	[972] 110 186	[1077] 122 183	[1181] 133 181	[1205] 136 178	[1437] 162 170
	[4]	[79] 9 344	[192] 22 343	[309] 35 335	[426] 48 334	[534] 60 321	[649] 73 320	[760] 86 319	[874] 99 315	[984] 111 291	[1090] 123 288	[1190] 134 279	[1218] 138 276	[1488] 168 270
	15,1	[75] 8 456	[191] 22 451	[304] 34 447	[419] 47 442	[532] 60 431	[645] 73 426	[759] 86 419	[871] 98 415	[982] 111 412	[1092] 123 401	[1197] 135 391	[1222] 138 386	[1458] 165 339
	[6]	[49] 6 569	[163] 18 565	[283] 32 560	[398] 45 552	[509] 58 547	[623] 70 541	[742] 84 532	[856] 97 525	[971] 110 512	[1080] 122 504	[1186] 134 498	[1209] 137 496	[1425] 161 475
	22,7	[24] 3 681	[156] 18 678	[270] 31 671	[385] 43 665	[502] 57 658	[614] 69 651	[729] 82 641	[845] 95 635	[963] 109 623	[1067] 121 612	[1182] 134 604	[1209] 137 601	[1472] 166 571
	[8]	[19] 2 793	[143] 16 788	[261] 29 787	[370] 42 778	[485] 55 771	[602] 68 762	[718] 81 753	[837] 95 746	[948] 107 733	[1064] 120 723	[1175] 133 715	[1199] 135 711	[1436] 162 677
	30,3	[13] 1 849	[120] 14 844	[236] 27 839	[352] 40 832	[471] 53 826	[590] 67 819	[707] 80 806	[823] 93 800	[939] 106 786	[1052] 119 779	[1165] 132 770	[1192] 135 766	[1462] 165 725
	37,9	[18]	[107] 12 1006	[215] 24 1003	[326] 37 998	[442] 50 988	[555] 63 976	[669] 76 975	[786] 89 965	[900] 102 952	[1016] 115 940	[1123] 127 924	[1152] 130 919	
	Max. Continuous	56,8												
Max. Intermittent	68,1													

**80 cm<sup>3</sup>/r [4.9 in<sup>3</sup>/r]**  
□ Pressure Bar [PSI]  
Continuous

		[200]	[400]	[600]	[800]	[1000]	[1200]	[1400]	[1600]	[1800]	[2000]	[2200]	[2250]	[2750]
		14	28	41	55	69	83	97	110	124	138	152	155	190
Flow LPM [GPM]	[2]	[123] 14 93	[265] 30 90	[405] 46 86	[544] 61 83	[680] 77 80	[804] 91 75	[934] 106 70	[1052] 119 63	[1181] 133 57	[1079] 122 43	[937] 106 24	[895] 101 20	
	7,6	[120] 14 187	[264] 30 185	[406] 46 183	[551] 62 179	[689] 78 175	[828] 94 171	[965] 109 166	[1101] 124 162	[1237] 140 156	[1369] 155 150	[1505] 170 142	[1537] 174 140	[1857] 210 121
	[4]	[113] 13 279	[255] 29 275	[398] 45 271	[542] 61 267	[682] 77 265	[823] 93 258	[963] 109 253	[1101] 124 248	[1239] 140 240	[1373] 155 232	[1508] 170 223	[1541] 174 221	[1868] 211 198
	15,1	[99] 11 372	[243] 27 367	[386] 44 364	[528] 60 359	[669] 76 354	[812] 92 351	[954] 108 343	[1094] 124 338	[1233] 139 333	[1368] 155 324	[1503] 170 315	[1537] 174 313	[1872] 212 289
	[6]	[84] 9 463	[228] 26 460	[371] 42 456	[514] 58 450	[655] 74 446	[798] 90 441	[941] 106 435	[1080] 122 428	[1219] 138 420	[1357] 153 412	[1496] 169 403	[1530] 173 399	[1870] 211 368
	22,7	[63] 7 557	[209] 24 552	[354] 40 547	[498] 56 543	[638] 72 537	[782] 88 530	[926] 105 523	[1067] 121 515	[1208] 136 509	[1346] 152 500	[1484] 168 489	[1520] 172 487	[1864] 211 470
	[8]	[55] 6 649	[185] 21 646	[331] 37 642	[476] 54 635	[620] 70 630	[762] 86 622	[904] 102 616	[1046] 118 609	[1188] 134 599	[1327] 150 592	[1467] 166 581	[1502] 170 578	[1842] 208 550
	30,3	[51] 6 694	[176] 20 691	[316] 36 687	[463] 52 680	[609] 69 673	[748] 85 668	[891] 101 660	[1037] 117 650	[1177] 133 642	[1316] 149 634	[1457] 165 622	[1491] 168 619	[1844] 208 598
	37,9	[20]	[160] 18 916	[305] 34 910	[455] 51 893	[578] 65 893	[737] 83 875	[857] 97 866	[968] 109 877	[1144] 129 843	[1277] 144 833	[1412] 160 839	[1446] 163 836	
	Max. Continuous	56,8												
Max. Intermittent	75,7													





# T Series (158-, 185-)

## Performance Data

Motors run with high efficiency in all areas designated with a number for torque and speed. For best motor life select a motor to run with a torque and speed range shown in the light shaded area.

Performance data is typical at 120 SUS. Actual data may vary slightly from unit to unit in production.

 Continuous  
 Intermittent

**102 cm<sup>3</sup>/r [6.2 in<sup>3</sup>/r]**  
□ Pressure Bar [PSI]  
Continuous

		[200]	[400]	[600]	[800]	[1000]	[1200]	[1400]	[1600]	[1800]	[2000]	[2200]	[2250]	[2750]	
		14	28	41	55	69	83	97	110	124	138	152	155	190	
Flow LPM [GPM]	[2]	[161]	[341]	[519]	[697]	[871]	[1030]	[1193]	[1349]	[1511]	[1496]	[1441]	[1421]	Max. Continuous	
	7,6	18 73	39 71	59 68	79 66	98 63	116 60	135 56	152 51	171 46	169 36	163 23	161 20		
	[4]	[157]	[340]	[520]	[702]	[879]	[1056]	[1229]	[1401]	[1567]	[1727]	[1889]	[1925]		Max. Intermittent
	15,1	18 149	38 146	59 144	79 141	99 138	119 135	139 131	158 128	177 124	195 118	213 111	217 109		
	[6]	[147]	[329]	[510]	[692]	[871]	[1050]	[1227]	[1401]	[1571]	[1731]	[1895]	[1936]		
	22,7	17 221	37 217	58 214	78 211	98 208	119 204	139 199	158 195	178 190	196 184	214 176	219 174		
	[8]	[132]	[315]	[497]	[675]	[857]	[1038]	[1216]	[1392]	[1564]	[1725]	[1891]	[1932]		
	30,3	15 294	36 290	56 287	76 284	97 280	117 277	137 271	157 267	177 262	195 255	214 247	218 245		
	[10]	[109]	[293]	[477]	[657]	[839]	[1018]	[1198]	[1374]	[1542]	[1711]	[1878]	[1918]		
	37,9	12 367	33 363	54 360	74 355	95 351	115 347	135 343	155 337	174 332	193 325	212 318	217 315		
[12]	[84]	[271]	[457]	[638]	[818]	[999]	[1179]	[1354]	[1527]	[1697]	[1858]	[1901]			
45,4	9 440	31 436	52 432	72 429	92 424	113 419	133 414	153 409	173 402	192 395	210 386	215 384			
[14]	[59]	[242]	[428]	[611]	[794]	[974]	[1151]	[1328]	[1502]	[1674]	[1841]	[1883]			
53,0	7 513	27 510	48 506	69 501	90 497	110 492	130 487	150 482	170 475	189 469	208 458	213 456			
Max. Continuous	[15]	[39]	[227]	[411]	[595]	[780]	[957]	[1136]	[1314]	[1486]	[1658]	[1828]	[1869]		
56,8	4 550	26 545	46 542	67 537	88 532	108 528	128 522	148 516	168 510	187 502	207 492	211 490			
Max. Intermittent	[20]	[154]	[328]	[515]	[710]	[874]	[1060]	[1243]	[1405]	[1579]	[1763]	[1803]			
75,7		17 724	37 718	58 720	80 709	99 707	120 696	140 684	159 683	178 670	199 659	204 660			

**131 cm<sup>3</sup>/r [8.0 in<sup>3</sup>/r]**  
□ Pressure Bar [PSI]  
Continuous

		[200]	[400]	[600]	[800]	[1000]	[1200]	[1400]	[1600]	[1800]	[2000]	[2500]	
		14	28	41	55	69	83	97	110	124	138	172	
Flow LPM [GPM]	[2]	[219]	[450]	[682]	[915]	[1144]	[1348]	[1561]	[1771]	[1979]	[2159]	Max. Continuous	
	7,6	25 57	51 55	77 53	103 51	129 49	152 47	176 43	200 40	224 36	244 30		
	[4]	[212]	[449]	[681]	[917]	[1148]	[1376]	[1600]	[1822]	[2025]	[2221]		Max. Intermittent
	15,1	24 115	51 113	77 110	104 109	130 107	155 105	181 102	206 99	229 96	251 91		
	[6]	[197]	[435]	[669]	[903]	[1139]	[1370]	[1600]	[1818]	[2032]	[2226]		
	22,7	22 171	49 168	76 166	102 163	129 160	155 157	181 154	205 150	230 147	252 142		
	[8]	[181]	[417]	[657]	[886]	[1122]	[1359]	[1589]	[1812]	[2022]	[2215]		
	30,3	20 227	47 225	74 222	100 219	127 217	154 213	180 209	205 206	228 202	250 196		
	[10]	[144]	[389]	[631]	[859]	[1098]	[1330]	[1562]	[1783]	[1993]	[2198]		
	37,9	16 284	44 281	71 278	97 275	124 271	150 267	176 265	201 261	225 258	248 252		
[12]	[114]	[361]	[605]	[838]	[1075]	[1307]	[1532]	[1755]	[1965]	[2177]			
45,4	13 341	41 338	68 334	95 332	121 328	148 325	173 321	198 318	222 312	246 307			
[14]	[82]	[327]	[569]	[803]	[1042]	[1273]	[1498]	[1722]	[1935]	[2147]			
53,0	9 397	37 394	64 391	91 387	118 384	144 361	169 378	195 374	219 370	243 365			
Max. Continuous	[15]	[66]	[302]	[550]	[785]	[1025]	[1254]	[1480]	[1704]	[1915]	[2119]		
56,8	7 426	34 423	62 422	89 415	116 412	142 409	167 405	193 402	216 398	239 392			
Max. Intermittent	[20]	[177]	[429]	[678]	[908]	[1143]	[1375]	[1596]	[1811]	[2017]			
75,7		20 565	48 560	77 556	103 553	129 549	155 546	180 541	205 536	228 527			

[302] } Torque [lb-in]  
34 } Nm  
423 } Speed RPM

# T Series (158-, 185-)

## Performance Data

Motors run with high efficiency in all areas designated with a number for torque and speed. For best motor life select a motor to run with a torque and speed range shown in the light shaded area.

Performance data is typical at 120 SUS. Actual data may vary slightly from unit to unit in production.

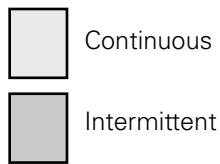

		157 cm <sup>3</sup> /r [9.6 in <sup>3</sup> /r] Δ Pressure Bar [PSI] Continuous										Max. Contin- uous	Max. Inter- mittent
		[200]	[400]	[600]	[800]	[1000]	[1200]	[1400]	[1600]	[1800]	[2000]	[2000]	[2500]
		14	28	41	55	69	83	97	110	124	138	138	172
[2]	7,6	[264] 30 47	[541] 61 45	[819] 93 44	[1092] 123 42	[1357] 153 40	[1605] 181 37	[1847] 209 34	[2084] 235 30	[2311] 261 25	[1858] 210 16		
[4]	15,1	[259] 29 96	[541] 61 95	[822] 93 92	[1101] 124 91	[1373] 155 90	[1638] 185 88	[1890] 214 85	[2145] 242 82	[2383] 269 78	[2613] 295 73	[3063] 346 60	
[6]	22,7	[241] 27 142	[526] 59 140	[808] 91 138	[1090] 123 136	[1368] 155 134	[1638] 185 132	[1900] 215 129	[2150] 243 125	[2399] 271 121	[2628] 297 114	[3169] 358 99	
[8]	30,3	[219] 25 189	[506] 57 187	[789] 89 185	[1068] 121 183	[1348] 152 181	[1625] 184 178	[1885] 213 175	[2140] 242 172	[2388] 270 166	[2619] 296 159	[3178] 359 140	
[10]	37,9	[180] 20 237	[472] 53 234	[759] 86 232	[1037] 117 230	[1319] 149 227	[1590] 180 224	[1853] 209 222	[2111] 239 218	[2355] 266 211	[2594] 293 203	[3170] 358 183	
[12]	45,4	[141] 16 284	[436] 49 282	[728] 82 279	[1010] 114 277	[1292] 146 274	[1561] 176 272	[1821] 206 269	[2079] 235 265	[2331] 263 257	[2573] 291 248	[3162] 357 225	
[14]	53,0	[101] 11 332	[397] 45 329	[687] 78 326	[969] 109 323	[1252] 141 321	[1519] 172 319	[1778] 201 316	[2040] 230 311	[2295] 259 305	[2539] 287 296	[3147] 356 274	
Max. Continuous	56,8	[81] 9 355	[367] 41 353	[665] 75 350	[944] 107 347	[1231] 139 344	[1497] 169 342	[1755] 198 339	[2018] 228 334	[2273] 257 327	[2512] 284 318	[3136] 354 300	
Max. Intermittent	75,7	[20]	[221] 25 472	[519] 59 467	[814] 92 464	[1095] 124 462	[1368] 155 459	[1631] 184 455	[1891] 214 450	[2149] 243 443	[2396] 271 433		

		195 cm <sup>3</sup> /r [11.9 in <sup>3</sup> /r] Δ Pressure Bar [PSI] Continuous										Max. Contin- uous	Max. Inter- mittent	
		[200]	[400]	[600]	[800]	[1000]	[1200]	[1400]	[1600]	[1750]	[1800]	[2000]	[2000]	[2500]
		14	28	41	55	69	83	97	110	121	125	138	138	172
[2]	7,6	[330] 37 38	[671] 76 36	[1016] 115 34	[1345] 152 33	[1654] 187 31	[1969] 222 28	[2242] 253 25	[2507] 283 20	[2689] 304 16	[2748] 310 14	[2973] 336 8		
[4]	15,1	[328] 37 77	[675] 76 77	[1026] 116 75	[1366] 154 73	[1692] 191 73	[2010] 227 71	[2289] 259 68	[2586] 292 65	[2799] 316 62	[2867] 324 61	[3144] 355 55	[3797] 429 40	
[6]	22,7	[306] 35 115	[658] 74 113	[1011] 114 111	[1360] 154 110	[1698] 192 109	[2021] 228 107	[2324] 263 104	[2604] 294 100	[2829] 320 97	[2901] 328 95	[3178] 359 87	[3831] 433 68	
[8]	30,3	[272] 31 153	[634] 72 151	[980] 111 150	[1331] 150 148	[1675] 189 146	[2003] 226 144	[2300] 260 142	[2592] 293 139	[2815] 318 134	[2888] 326 132	[3174] 359 123	[3864] 437 99	
[10]	37,9	[238] 27 192	[596] 67 189	[945] 107 188	[1296] 146 186	[1637] 185 184	[1960] 221 183	[2255] 255 181	[2565] 290 176	[2786] 315 168	[2857] 323 166	[3140] 355 156	[3816] 431 133	
[12]	45,4	[181] 20 230	[545] 62 228	[908] 103 226	[1260] 142 224	[1607] 182 222	[1924] 217 221	[2223] 251 219	[2529] 286 213	[2759] 312 207	[2836] 320 204	[3121] 353 192	[3807] 430 160	
[14]	53,0	[154] 17 268	[500] 56 266	[860] 97 264	[1211] 137 261	[1556] 176 259	[1869] 211 259	[2175] 246 256	[2483] 281 251	[2713] 307 244	[2792] 315 242	[3080] 348 229	[3778] 427 199	
Max. Continuous	56,8	[140] 16 287	[465] 53 285	[832] 94 283	[1179] 133 281	[1525] 172 279	[1835] 207 278	[2144] 242 275	[2459] 278 269	[2693] 304 262	[2768] 313 260	[3061] 346 247	[3764] 425 220	
Max. Intermittent	75,7	[20]	[291] 33 382	[653] 74 378	[1013] 114 375	[1366] 154 373	[1689] 191 372	[1987] 225 368	[2298] 260 363	[2540] 287 356	[2622] 296 353	[2928] 331 342		





# T Series (158-, 185-)

## Performance Data

Motors run with high efficiency in all areas designated with a number for torque and speed. For best motor life select a motor to run with a torque and speed range shown in the light shaded area.

Performance data is typical at 120 SUS. Actual data may vary slightly from unit to unit in production.

 Continuous  
 Intermittent

### 244 cm<sup>3</sup>/r [14.9 in<sup>3</sup>/r]

□ Pressure Bar [PSI]

Continuous

Max. Continuous

Max. Intermittent

		[200]	[400]	[600]	[800]	[1000]	[1200]	[1400]	[1600]	[1800]	[1650]	[1800]	[1850]	[2250]
		14	28	41	55	69	83	97	110	114	125	127	155	
Flow LPM [GPM]	[2]	[406]	[833]	[1260]	[1655]	[2038]	[2403]	[2707]	[2597]	[2552]	[2373]	[2299]		
	7,6	46 30	94 29	142 27	187 26	230 24	272 22	306 17	293 12	288 11	268 7	260 6		
	[4]	[404]	[843]	[1277]	[1695]	[2083]	[2468]	[2820]	[3177]	[3261]	[3509]	[3589]	[4194]	
	15,1	46 62	95 62	144 60	192 59	235 59	279 55	319 50	359 50	368 49	396 46	406 44	474 35	
	[6]	[382]	[823]	[1261]	[1687]	[2088]	[2477]	[2843]	[3196]	[3285]	[3547]	[3633]	[4290]	
	22,7	43 92	93 92	142 90	191 89	236 88	280 86	321 82	361 78	371 76	401 72	410 71	485 60	
	[8]	[341]	[787]	[1220]	[1651]	[2059]	[2454]	[2820]	[3177]	[3265]	[3530]	[3615]	[4285]	
	30,3	39 123	89 122	138 121	187 120	233 119	277 116	319 113	359 108	369 106	399 101	408 99	484 85	
	[10]	[297]	[744]	[1177]	[1611]	[2017]	[2412]	[2774]	[3151]	[3241]	[3504]	[3593]	[4269]	
	37,9	34 154	84 152	133 151	182 150	228 148	273 146	313 143	356 136	366 134	396 127	406 125	482 107	
[12]	[225]	[687]	[1132]	[1553]	[1967]	[2360]	[2734]	[3105]	[3194]	[3466]	[3554]	[4237]		
45,4	25 184	78 183	128 181	175 180	222 179	267 177	309 173	351 166	361 163	392 156	402 153	479 134		
[14]	[154]	[628]	[1072]	[1498]	[1910]	[2298]	[2674]	[3052]	[3148]	[3419]	[3510]	[4226]		
53,0	17 214	71 213	121 212	169 211	216 209	260 207	302 202	345 195	356 193	386 186	397 182	477 161		
[15]	[119]	[586]	[1035]	[1458]	[1872]	[2261]	[2637]	[3022]	[3116]	[3389]	[3488]	[4220]		
56,8	13 229	66 228	127 227	165 226	212 224	255 222	298 217	341 209	352 207	383 200	394 197	477 174		
Max. Continuous	[20]	[372]	[816]	[1251]	[1663]	[2067]	[2448]	[2832]	[2928]	[3214]	[3312]			
Max. Intermittent	75,7	42 305	92 303	141 301	188 300	234 297	277 292	320 284	331 281	363 273	374 270			

### 306 cm<sup>3</sup>/r [18.7 in<sup>3</sup>/r]

□ Pressure Bar [PSI]

Continuous

Max. Continuous

Max. Intermittent

		[200]	[400]	[600]	[800]	[1000]	[1200]	[1400]	[1500]	[1600]	[1800]
		14	28	41	55	69	83	97	103	110	124
Flow LPM [GPM]	[2]	[499]	[1035]	[1560]	[2034]	[2501]	[2912]	[3239]	[2859]	[2400]	
	7,6	56 24	117 23	176 22	230 21	283 19	329 16	366 11	323 8	271 5	
	[4]	[497]	[1052]	[1590]	[2101]	[2561]	[3023]	[3464]	[3680]	[3886]	[4221]
	15,1	56 49	119 49	180 48	237 48	289 47	342 47	391 44	416 41	439 38	477 30
	[6]	[480]	[1031]	[1578]	[2096]	[2564]	[3023]	[3464]	[3689]	[3905]	[4275]
	22,7	54 74	116 74	178 72	237 72	290 71	342 69	391 64	417 62	441 60	483 51
	[8]	[427]	[975]	[1520]	[2051]	[2525]	[2998]	[3448]	[3667]	[3881]	[4264]
	30,3	48 99	110 98	172 97	232 97	285 96	339 94	390 89	414 86	438 83	482 73
	[10]	[370]	[930]	[1467]	[2001]	[2477]	[2955]	[3406]	[3631]	[3852]	[4264]
	37,9	42 123	105 122	166 121	226 120	280 120	334 117	385 112	410 108	435 104	482 92
[12]	[281]	[871]	[1410]	[1908]	[2400]	[2887]	[3352]	[3573]	[3790]	[4189]	
45,4	32 147	98 146	159 145	216 145	271 142	326 136	379 131	404 131	428 127	473 112	
[14]	[192]	[791]	[1338]	[1851]	[2338]	[2816]	[3281]	[3511]	[3743]	[4135]	
53,0	22 171	89 171	151 170	209 170	264 169	318 165	371 159	397 154	423 150	467 133	
[15]	[148]	[738]	[1288]	[1803]	[2287]	[2773]	[3243]	[3475]	[3705]	[4098]	
56,8	17 183	83 183	146 182	204 182	258 181	313 177	366 171	393 165	419 160	463 146	
Max. Continuous	[20]	[476]	[1020]	[1544]	[2010]	[2519]	[3010]	[3243]	[3495]		
Max. Intermittent	75,7	54 243	115 242	174 242	227 241	285 238	340 231	366 226	395 209		

[738]  
 83 } Torque [lb-in]  
 183 } Nm  
 Speed RPM

### 370 cm<sup>3</sup>/r [22.6 in<sup>3</sup>/r]

□ Pressure Bar [PSI]

Continuous

Max. Continuous

Max. Intermittent

		[200]	[400]	[600]	[800]	[1000]	[1200]	[1300]	[1500]
		14	28	41	55	69	83	90	103
Flow LPM [GPM]	[2]	[590]	[1237]	[1858]	[2406]	[2953]	[3388]	[3586]	
	7,6	67 20	140 19	210 18	272 17	334 15	383 12	405 11	
	[4]	[588]	[1263]	[1906]	[2506]	[3029]	[3557]	[3811]	[4252]
	15,1	66 41	143 41	215 40	283 40	342 39	402 38	431 37	480 36
	[6]	[580]	[1245]	[1899]	[2506]	[3029]	[3544]	[3788]	[4300]
	22,7	66 61	141 60	215 59	283 58	342 57	400 56	428 56	486 54
	[8]	[514]	[1164]	[1824]	[2452]	[2975]	[3518]	[3783]	[4284]
	30,3	58 82	132 81	206 80	277 79	336 78	397 77	427 77	484 75
	[10]	[444]	[1119]	[1759]	[2391]	[2928]	[3479]	[3750]	[4275]
	37,9	50 102	126 102	199 101	270 101	331 100	393 97	424 96	483 93
[12]	[337]	[1062]	[1690]	[2256]	[2813]	[3393]	[3685]	[4273]	
45,4	38 122	120 121	191 120	255 119	318 119	383 118	416 116	483 112	
[14]	[231]	[958]	[1608]	[2201]	[2748]	[3319]	[3610]	[4198]	
53,0	26 142	108 141	182 140	249 139	310 138	375 137	408 134	474 129	
[15]	[178]	[896]	[1543]	[2147]	[2683]	[3272]	[3572]	[4187]	
56,8	20 152	101 152	174 151	243 150	303 149	370 147	404 146	473 140	
Max. Continuous	[20]	[587]	[1228]	[1833]	[2331]	[2948]	[3273]		
Max. Intermittent	75,7	66 202	139 201	207 201	263 200	333 198	370 196		

# T Series (158-)

## Dimensions

(Refer to pages B-4-19 thru B-4-22 for shaft and port dimensions.)

### Ports

- 7/8 -14 INF O-ring Ports (2)
- 1/2 -14 NPTF (2)
- G 1/2 BSP (2)
- Manifold Ports (5/16-18 mounting threads)

### Note:

Mounting Surface Flatness Requirement is  $\nabla$ , 13 mm [.005 inch] Max.

### Standard Rotation Viewed from Shaft End

- Port A Pressurized — CW
- Port B Pressurized — CCW

## 2 Bolt Flange

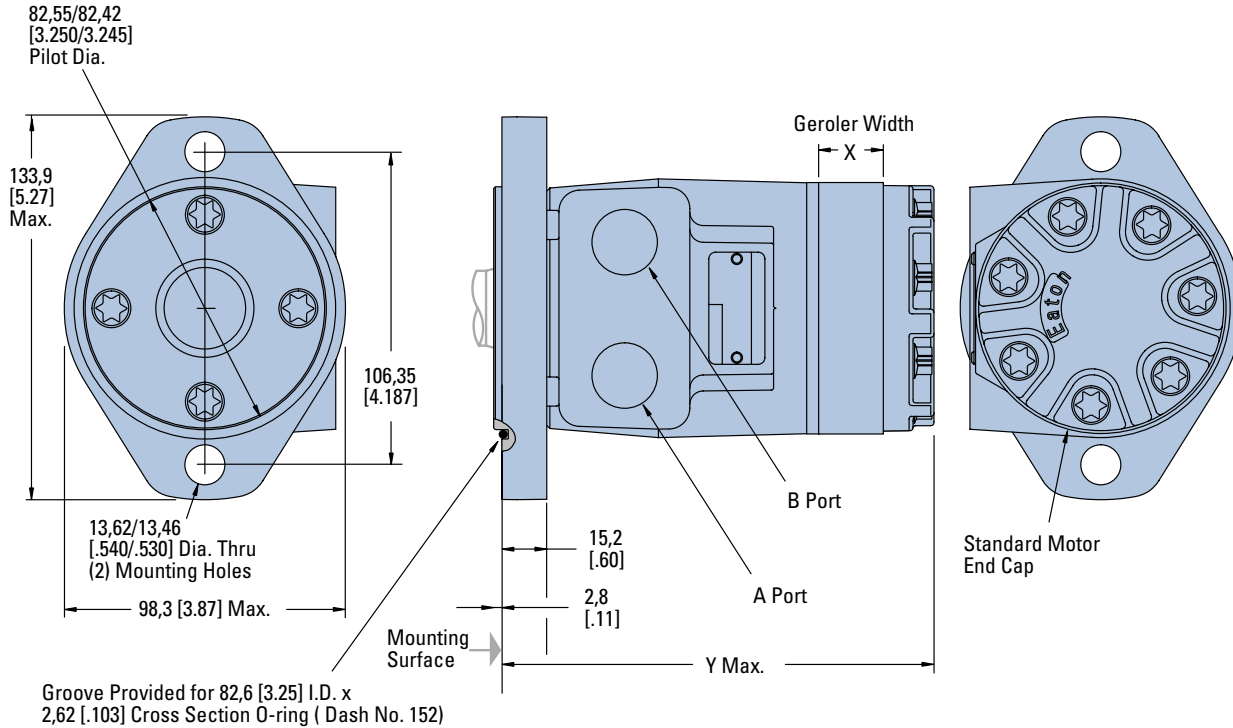

## 4 Bolt Flange

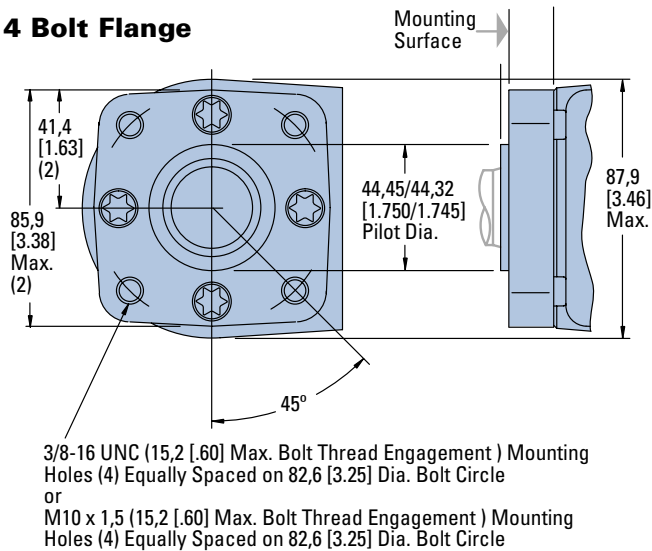

### 2 AND 4 BOLT FLANGE PORT DIMENSIONS

Displacement cm <sup>3</sup> /r [in <sup>3</sup> /r]	X mm [inch]	Y mm [inch]
36 [2.2]	6,6 [.26]	132,2 [5.21]
49 [3.0]	9,1 [.36]	134,6 [5.30]
66 [4.0]	12,2 [.48]	137,7 [5.42]
80 [4.9]	14,7 [.58]	140,3 [5.53]
102 [6.2]	18,5 [.73]	144,3 [5.68]
131 [8.0]	24,1 [.95]	149,6 [5.89]
157 [9.6]	29,0 [1.14]	154,5 [6.09]
195 [11.9]	35,6 [1.40]	161,3 [6.35]
244 [14.9]	44,7 [1.76]	170,3 [6.71]
306 [18.7]	56,1 [2.21]	181,6 [7.16]
370 [22.6]	72,1 [2.84]	197,9 [7.79]



# T Series (158-)

## Product Numbers

Use digit prefix—158- plus four digit number from charts for complete product number—Example: 158-1067.

**Orders will not be accepted without the three-digit prefix.**

### Standard

MOUNTING	SHAFT	PORT SIZE	DISPL. cm <sup>3</sup> /r [in <sup>3</sup> /r] / PRODUCT NUMBER									
			36 [2.2]	49 [3.0]	66 [4.0]	80 [4.9]	102 [6.2]	131 [8.0]	157 [9.6]	195 [11.9]	244 [14.9]	306 [18.7]
2 Bolt Flange	1 in. Straight w/Woodruff Key	7/8 -14 O-ring	158- — —	-1537	-1034	-1035	-1538	-1036	-1037	-1038	-1039	-1040
		1/2 NPTF	158- — —	-1540	-1026	-1027	-1541	-1028	-1029	-1030	-1031	-1032
		Manifold*	158- — —	-1543	-1042	-1043	-1544	-1044	-1045	-1046	-1047	-1048
	1 in. SAE 6B Splined	7/8 -14 O-ring	158- — —	-1552	-1082	-1083	-1553	-1084	-1085	-1086	-1087	-1088
		1/2 NPTF	158- — —	-1555	-1074	-1075	-1556	-1076	-1077	-1078	-1079	-1080
		Manifold*	158- — —	-1558	-1090	-1091	-1559	-1092	-1093	-1094	-1095	-1096
4 Bolt Flange	1 in. Straight w/Woodruff Key	7/8 -14 O-ring	158- — —	-1570	-1010	-1011	-1571	-1012	-1013	-1014	-1015	-1016
		1/2 NPTF	158- — —	-1573	-1002	-1003	-1574	-1004	-1005	-1006	-1007	-1008
		Manifold*	158- — —	-1576	-1018	-1019	-1577	-1020	-1021	-1022	-1023	-1024
	1 in. SAE 6B Splined	7/8 -14 O-ring	158- — —	-1579	-1058	-1059	-1580	-1060	-1061	-1062	-1063	-1064
		1/2 NPTF	158- — —	-1582	-1050	-1051	-1583	-1052	-1053	-1054	-1055	-1056
		Manifold*	158- — —	-1585	-1066	-1067	-1586	-1068	-1069	-1070	-1071	-1072

158-1067

### T Series Motors with Corrosion Protection

MOUNTING	SHAFT	PORT SIZE	DISPL. cm <sup>3</sup> /r [in <sup>3</sup> /r] / PRODUCT NUMBER										
			36 [2.2]	49 [3.0]	66 [4.0]	80 [4.9]	102 [6.2]	131 [8.0]	157 [9.6]	195 [11.9]	244 [14.9]	306 [18.7]	370 [22.6]
2 Bolt Flange	1 in. Straight w/ Woodruff Key	7/8 -14 O-ring	158- — —	—	—	1645	—	—	—	—	-1649	—	-1650
4 Bolt Flange		1/2 NPTF	158- — —	—	—	—	—	—	—	—	-1620	—	-1621

158-1620

### T Series Motors with Low Speed Valving

MOUNTING	SHAFT	PORT SIZE	DISPL. cm <sup>3</sup> /r [in <sup>3</sup> /r] / PRODUCT NUMBER										
			36 [2.2]	49 [3.0]	66 [4.0]	80 [4.9]	102 [6.2]	131 [8.0]	157 [9.6]	195 [11.9]	244 [14.9]	306 [18.7]	370 [22.6]
2 Bolt Flange	1 in. Straight w/Woodruff Key	7/8 -14 O-ring	158- — —	—	—	-1427	-1428	—	—	-1430	-1431	-1432	-1433
		1/2 NPTF	158- — —	—	—	-1419	-1420	—	—	-1422	-1423	-1424	-1425
		Manifold*	158- — —	—	—	—	—	—	—	—	—	—	—
4 Bolt Flange	1 in. SAE 6B Splined	7/8 -14 O-ring	158- — —	—	—	-1525	—	—	—	—	-1675	—	—
		1/2 NPTF	158- — —	—	—	—	-1634	—	—	—	—	—	—
		Manifold*	158- — —	—	—	-1522	-2678	—	—	—	—	—	-1527
4 Bolt Flange	1 in. Straight w/ Woodruff Key	7/8 -14 O-ring	158- — —	—	-1625	-1410	-1411	-1626	-1412	-1413	-1414	-1415	-1416
		1/2 NPTF	158- — —	—	-1644	-1402	-1403	—	-1404	-1405	-1406	-1407	-1408

158-1403

\*Manifold product numbers shown are for motors with four 5/16-18 port face mounting threads. Manifold, manifold mounting O-rings and bolts are NOT included.

For T Series Motors with a configuration Not Shown in the charts above: Use the model code system on page B-4-10 to specify the product in detail.

# T Series (158-)

## Model Code

The following 16-digit coding system has been developed to identify all of the configuration options for the T motor. Use this model code to specify a motor with the desired features. All 16-digits of the code must be present when ordering. You may want to photocopy the matrix below to ensure that each number is entered in the correct box.

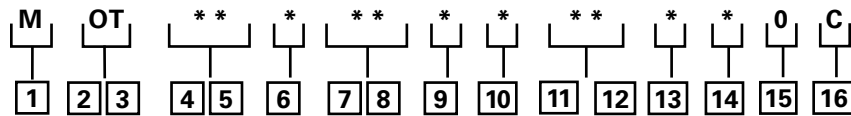

### 1 Product

**M** – Motor

### 2, 3 Product Series

**OT** – T Series

### 4, 5 Displacement cm<sup>3</sup>/r [in<sup>3</sup>/r]

**02** – 36 [2.2]

**03** – 49 [3.0]

**04** – 66 [4.0]

**05** – 80 [4.9]

**06** – 102 [6.2]

**08** – 131 [8.0]

**10** – 157 [9.6]

**12** – 195 [11.9]

**15** – 244 [14.9]

**19** – 306 [18.7]

**23** – 370 [22.6]

### 6 Mounting Type

**A** – 2 Bolt (Standard) 82,6 [3.25] Pilot Dia. and 13,59 [.535] Dia. Mounting Holes 106,2 [4.18] Dia. B.C.

**B** – 4 Bolt (Standard) 44,4 [1.75] Pilot Dia. and 3/8 -16 Mounting Holes 82,6 [3.25] Dia. B.C.

**E** – 4 Bolt (Standard) 44,4 [1.75] Pilot Dia. and M10 x 1,5 Mounting Holes 82,6 [3.25] Dia. B.C.

**H** – 2 Bolt (Std.) 101,6 [4.00] Pilot Dia. and 14,35 [.565] Dia. Mounting Holes 146,0 [5.75] Dia. B.C. (SAE B)

**K** – 4 Bolt Magneto 82,6 [3.25] Pilot Dia. and 13,59 [.535] Dia. Mounting Holes 106,2 [4.18] Dia. B.C.

### 7, 8 Output Shaft

**01 01** – 1 inch Dia. Straight with Woodruff Key and 1/4 -20 Threaded Hole

**02** – 1 inch Dia. SAE 6B Splined with 1/4 -20 Threaded Hole

**07** – 1 inch Dia. Straight with 7,9 [.31] Dia. Crosshole 11,2 [.44] from End

**08** – 1 inch Dia. Straight with 10,2 [.40] Dia. Crosshole 15,7 [.62] from End and 1/4 -20 Threaded Hole

**16** – 7/8 inch Dia. SAE B 13T Splined

**17** – 7/8 inch Dia. SAE B Straight with Square Key

**18** – 1 inch Dia. Tapered with Woodruff Key and Nut

**24** – 25mm Dia. Straight with 8mm Key and 8mm x 1.2 Threaded Hole

**27** – 1 inch Dia. Straight with Woodruff Key and 1/4-20 Threaded Hole (Plated for Corrosion Protection)

### 9 Ports

**A** – 7/8 -14 O-ring

**B** – 1/2 -14 NPTF

**C** – Manifold (5/16-18 Mounting Threads)

**D** – Manifold (M8 x 1,25 Mounting Threads)

**E** – G 1/2 (BSP) End Cap

### 10 Case Flow Options

**0** – No Case Drain

**1** – 7/16 -20 O-ring Port End Cap

**2** – G 1/4 (BSP) End Cap

### 11, 12 Special Features (Hardware)

**00** – None

**AB** – Low Speed Valve

**AC** – Viton Shaft Seal

**BZ** – Speed Sensor

**DS** – High Pressure Shaft Seal

### 13 Special Features (Assembly)

**0** – None

**1** – Reverse Rotation

**2** – Flange Rotated 90°

### 14 Paint/ Special Packaging

**0** – No Paint, Individual Box

**A** – Painted Low Gloss Black, Individual Box

**B** – No Paint, Bulk Box Option

**C** – Painted Low Gloss Black, Bulk Box Option

### 15 Eaton Assigned Code when Applicable

**0** – Assigned Code

### 16 Eaton Assigned Design Code

**C** – Assigned Design Code

# T Series with Parking Brake (185-)

## Highlights

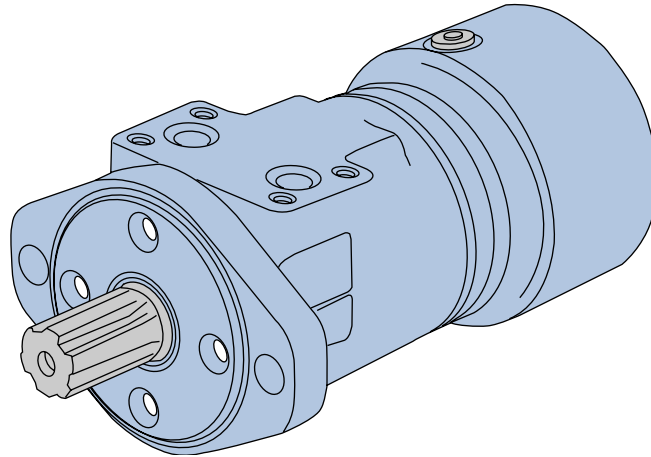

### Description

Eaton's latest offering in LSHT motor technology is the new T Series Motor with Parking Brake.

T Series Motor with Parking Brake utilizes brake pads that rotate at 6 times the speed of the output shaft, thereby giving the brake a 6-to-1 mechanical advantage. The T Series Motor with Parking Brake utilizes the same Geroler, and Spool Valve technologies as the standard Char-Lynn motors. Therefore, in addition to providing dependable, load-holding capability, T Series Motor with Parking Brake provides the same smooth, reliable and efficient performance as the T Series Motor.

### Specifications

Geroler Element	11 Displacements
Flow l/min [GPM]	55 [15] Continuous*** 75 [20] Intermittent**
Speed	Up to 1055 RPM
Pressure bar [PSI]	155 [2250] Cont.*** 190 [2750] Inter.**
Torque Nm [lb-in]	441 [3905] Cont.*** 486 [4300] Inter.**

\*\*\* Continuous— (Cont.) Continuous rating, motor may be run continuously at these ratings.

\*\* Intermittent— (Inter.) Intermittent operation, 10% of every minute.

### Features

- Integrated, Compact, Patented Design
- Capability of Combining 4 inventory items into a single assembly (motor, brake, counter-balance valve, brake release line)
- Rear-mounted integrated brake with 6:1 torque advantage
- Access port for manual brake release (for overriding brake in the event of loss of release pressure.)

### Benefits

- Cost-effective Packaged System Solution
- Simplifies ordering and inventory requirements
- Reduces assembly labor
- Design Flexibility
- Wet brake is environmentally protected and provides long life

### Applications

- Truck-Mounted Equipment (boom rotate and winch)
- Conveyors – Positioners – Indexers
- Marine Cranes (boom rotate and winch)
- Fishing Winches
- Recycling and Refuse Equipment
- Vehicle Recovery Winches
- Mining Equipment
- Specialty Utility Vehicles/ Machines
- Forestry Grapples
- Agricultural Equipment
- Railroad Equipment
- Airport Support Vehicles
- Lawn & Turf Equipment
- Anywhere Load-Holding is Needed in a Low-Speed High-Torque Drive System



Crane and winches



Boom Lift (Swing)



Maintenance Equipment

# T Series with Parking Brake (185-)

## Application Information

### Principle of Operation

The wet brake is a spring-applied / pressure release design. Load-holding is applied by a mechanical spring and released by hydraulic pressure. The spring force holds the brake on when hydraulic pressure is absent.

### Release Pressure

Release pressure is defined as the amount of pressure required to fully release the brake. The brake pressure cavity is common (shared) with the motor case. As a result, maximum release pressure is constrained by the motor case-pressure capability. The T Series Motor with Parking Brake incorporates a shaft seal capable up to 1500 psi (see page B-4-15). However, seal life is reduced at higher case pressure.

### Residual Pressure

Residual pressure is the pressure trapped in the system by restrictions or long return lines.

Residual pressure in the motor case will lower the rated load holding torque of the brake.

Therefore, special attention needs to be given when applying this product. Keep in mind that long return lines create higher pressure that will reduce brake holding torque. In applications with high system pressures, the use of a pressure reducing valve to limit case and release pressure is recommended.

### Holding Torque and Motor Output Torque

Holding torque is based on grade holding requirements for a vehicle or other load holding requirements in the application. System pressure and motor displacement are the factors in determining motor output torque. Motor displacement, measured in cubic centimeters or cubic inches, is the volume of fluid required to make one revolution. Motor output torque is the rotary force and is usually measured in inch pounds, newton meters or foot pounds. Maximum motor torque depends on pressure and motor displacement. Both output shaft size and shaft type can also affect motor torque. The T Series Motor with Parking Brake load holding capacity is factory set to match any limiting factor in each specific motor configuration (e.g. displacement, output shaft, etc).

### Note:

Eaton Corporation does not approve any products for customer applications. It is the sole responsibility of the customer to qualify and verify the correct operation of products in their systems.

### Note:

Special attention should be given to system back pressure. System back pressure directly affects brake release pressure and can cause the brake to release at undesired conditions.

### Typical Applications

#### Winch

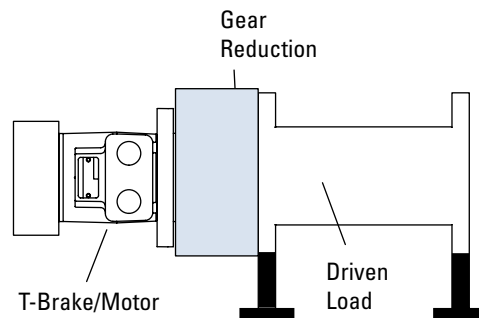

#### Machine Drive

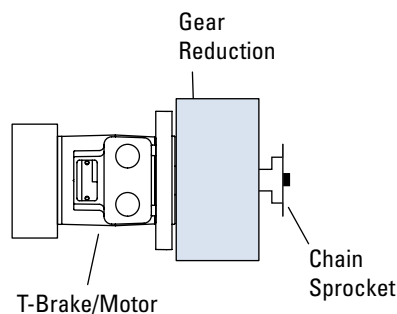

#### Swing Boom

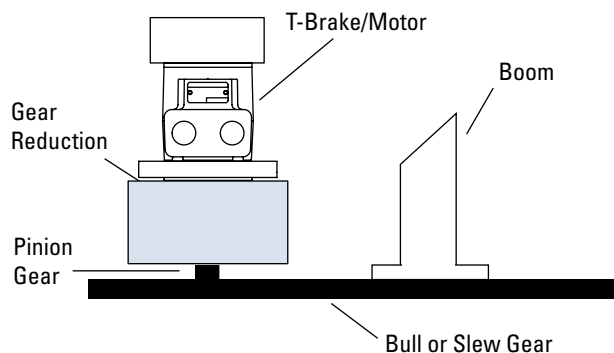

# T Series with Parking Brake (185-)

## Specifications

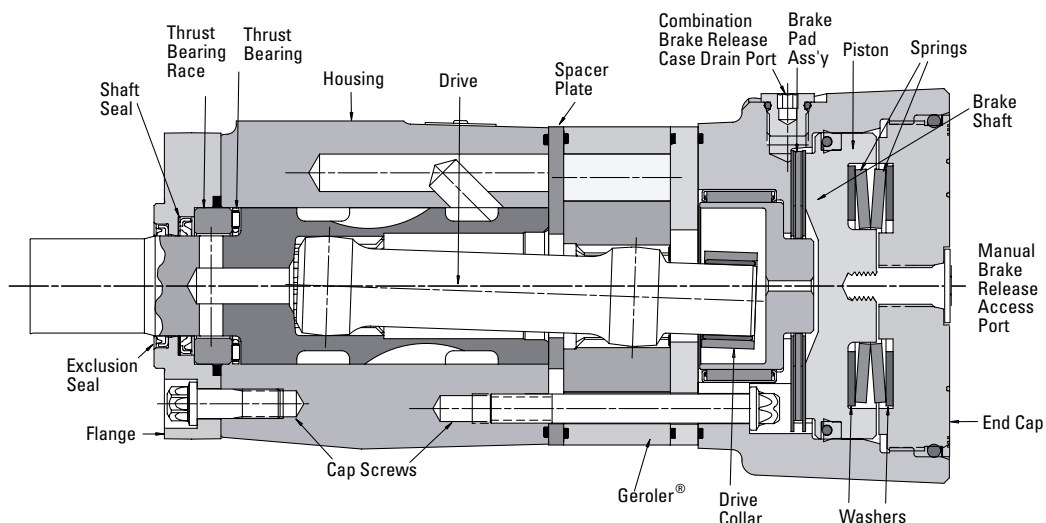

### SPECIFICATION DATA — T SERIES WITH PARKING BRAKE MOTORS

Displ. cm <sup>3</sup> /r [in <sup>3</sup> /r]	36 [2.2]	49 [3.0]	66 [4.0]	80 [4.9]	102 [6.2]	131 [8.0]	157 [9.6]	195 [11.9]	244 [14.9]	306 [18.7]	370 [22.6]
Max. Speed (RPM) @ Continuous Flow	1021	906	849	694	550	426	355	287	229	183	152
Flow LPM [GPM]	Continuous 38 [10] Intermittent 38 [10]	45 [12] 57 [15]	57 [15] 68 [18]	57 [15] 76 [20]	57 [15] 76 [20]	57 [15] 76 [20]	57 [15] 76 [20]	57 [15] 76 [20]	57 [15] 76 [20]	57 [15] 76 [20]	57 [15] 76 [20]
Torque Nm [lb-in]	Continuous 76 [672] Intermittent ** 93 [824]	105 [928] 118 [1131]	138 [1222] 168 [1488]	174 [1541] 212 [1872]	219 [1936] 264 [2339]	251 [2226] 307 [2718]	297 [2628] 359 [3178]	359 [3178] 437 [3864]	410 [3633] 485 [4290]	441 [3905] 483 [4275]	430 [3811] 486 [4300]
Pressure Δ Bar [Δ PSI]	Continuous * 155 [2250] Intermittent * ** 190 [2750]	155 [2250] 190 [2750]	155 [2250] 190 [2750]	155 [2250] 190 [2750]	155 [2250] 190 [2750]	138 [2000] 172 [2500]	138 [2000] 172 [2500]	138 [2000] 172 [2500]	127 [1850] 155 [2250]	110 [1600] 124 [1800]	90 [1300] 103 [1500]

### Note:

See page B-4-2 for additional motor specification notes and definitions. The T Series with Parking Brake performance is similar to the standard T Series motor. High speed conditions may reduce performance on T Series with Parking Brake.

### T SERIES BRAKE HOLDING TORQUE SETTINGS:

Shaft Code	Output Shaft Description	[in <sup>3</sup> /r]	2.2	3.0	4.0	4.9	6.2	8.0	9.6	11.9	14.9	18.7	22.6
18	1" Tapered w/key and nut		2,000	2,000	2,000	3,500	3,500	3,500	5,000	5,000	5,000	5,000	5,000
02	1" SAE 6B Splined		2,000	2,000	2,000	3,500	3,500	3,500	5,000	5,000	5,000	5,000	5,000
24	25mm Straight w/key		2,000	2,000	2,000	3,500	3,500	3,500	3,500	3,500	3,500	3,500	3,500
01	1" Straight w/key		2,000	2,000	2,000	3,500	3,500	3,500	3,500	3,500	3,500	3,500	3,500
07	1" Straight w/.31 dia. crosshole		2,000	2,000	2,000	3,500	3,500	3,500	3,500	3,500	3,500	3,500	3,500
08	1" Straight w/.40 dia. crosshole		2,000	2,000	2,000	3,500	3,500	3,500	3,500	3,500	3,500	3,500	3,500
16	7/8" SAE B 13T Splined		2,000	2,000	2,000	2,000	2,000	2,000	2,000	2,000	2,000	2,000	2,000
17	7/8" SAE B Straight w/key		2,000	2,000	2,000	2,000	2,000	2,000	2,000	2,000	2,000	2,000	2,000

**in-lbs** Full Capacity Brake

**in-lbs** Limited Capacity Brake

### Note:

The factory setting values are used for each motor based on motor displacement and shaft type.

# T Series with Parking Brake (185-)

## Standard Rotation Viewed from Shaft End

Port A Pressurized — CW  
 Port B Pressurized — CCW

## Dimensions

(Refer to pages B-4-19 thru B-4-22 for shaft and port dimensions.)

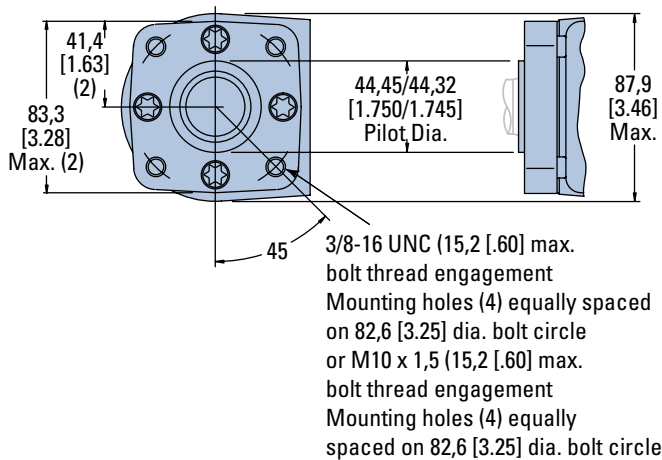
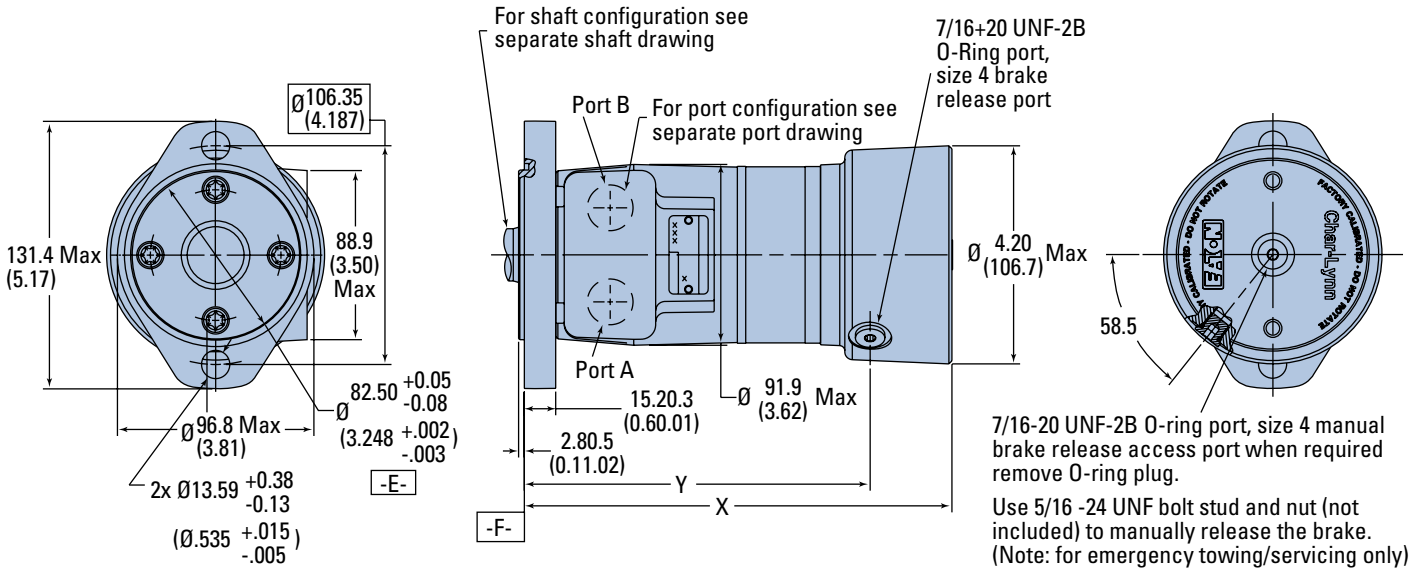

### T-SERIES WITH PARKING BRAKE DIMENSIONS

Displacement cm <sup>3</sup> /r [in <sup>3</sup> /r]	X		Y	
	mm [inch]	mm [inch]	mm [inch]	mm [inch]
02	190.2 [7.49]	145.8±0.9 [5.74±0.3]		
A2	190.8 [7.51]	146.4±0.9 [5.76±0.3]		
03	192.5 [7.58]	148.2±0.9 [5.84±0.3]		
A3	194.3 [7.65]	150.0±0.9 [5.90±0.3]		
04	195.6 [7.70]	151.2±0.9 [5.95±0.3]		
05	198.4 [7.81]	153.9±0.9 [6.06±0.3]		
06	202.2 [7.96]	157.8±0.9 [6.21±0.3]		
08	207.5 [8.17]	163.2±0.9 [6.42±0.3]		
10	212.6 [8.37]	168.1±0.9 [6.62±0.3]		
12	219.2 [8.63]	174.8±0.9 [6.88±0.3]		
15	228.3 [8.99]	183.8±0.9 [7.24±0.3]		
19	239.5 [9.43]	195.2±0.9 [7.69±0.3]		
23	251.2 [9.89]	206.9±0.9 [8.14±0.3]		

### Note:

#### Standard Rotation

When facing shaft end of motor shaft to rotate clockwise when port "A" is pressurized, counterclockwise when port "B" is pressurized

#### Reverse Rotation

When facing shaft end of motor shaft will rotate clockwise when port "B" is pressurized, counterclockwise when port "A" is pressurized

# T Series with Parking Brake (185-)

## Brake Release and Motor Case Pressure

The T Series Motor with Parking Brake is durable and has long life as long as the recommended case pressure is not exceeded. Allowable case pressure is highest at low shaft speeds. Motor life will be shortened if case pressure exceeds recommended ratings (acceptability may vary with application).

Refer to the Case Pressure/ Shaft Seal chart below. This chart is based on case pressure and motor shaft speed. A minimum release pressure of 17 Bar [250 PSI] must be maintained to fully release the brake.

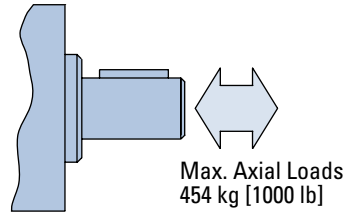
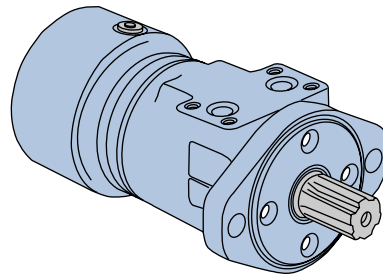

$$P_C \approx 6 DP + P_2$$

$P_C$  = Case Pressure  
 $P_1$  = Inlet Line Pressure  
 $P_2$  = Back Pressure  
 $DP = P_1 - P_2$

### Case Pressure/Shaft Seal

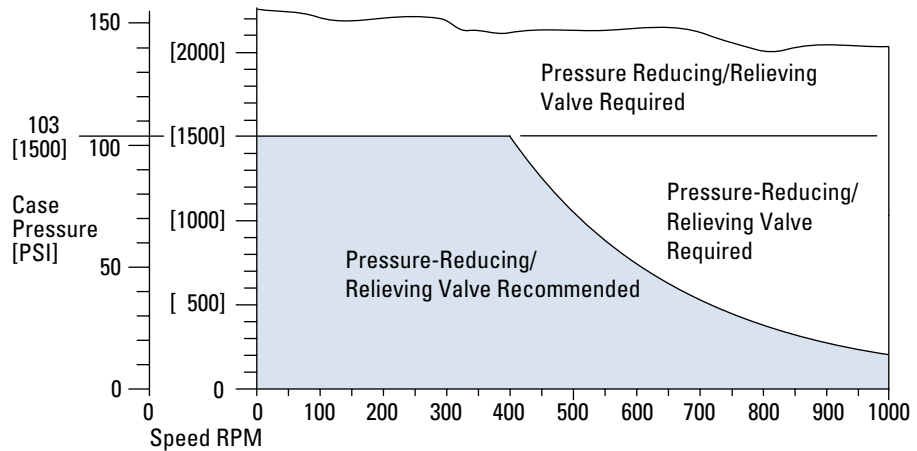

# T Series with Parking Brake (185-)

## Product Numbers

Use digit prefix —  
185 plus four digit number  
from charts for complete  
product number —  
Example 185-2068.

**Orders will not be accepted  
without three digit prefix.**

### Standard Valving

MOUNTING	SHAFT	PORT SIZE	DISPL. cm <sup>3</sup> /r [in <sup>3</sup> /r] / PRODUCT NUMBER									
			3.0	4.0	4.9	6.2	8.0	9.6	11.9	14.9	18.7	22.6
2-Bolt	1" Keyed	7/8-14 O-ring Manifold	185-2000 185-2010	2001 2011	2002 2012	2003 2013	2004 2014	2005 2015	2006 2016	2007 2017	2008 2018	2009 2019
		6B Splined	7/8-14 O-ring Manifold	185-2020 185-2030	2021 2031	2022 2032	2023 2033	2024 2034	2025 2035	2026 2036	2027 2037	2028 2038
	13T Splined 16/32 pitch	7/8-14 O-ring Manifold	185-2040 185-2050	2041 2051	2042 2052	2043 2053	2044 2054	2045 2055	2046 2056	2047 2057	2048 2058	2049 2059
4-Bolt	1" Keyed	7/8-14 O-ring Manifold	185-2060 185-2070	2061 2071	2062 2072	2063 2073	2064 2074	2065 2075	2066 2076	2067 2077	2068 2078	2069 2079
		6B Splined	7/8-14 O-ring Manifold	185-2080 185-2090	2081 2091	2082 2092	2083 2093	2084 2094	2085 2095	2086 2096	2087 2097	2088 2098
	13T Splined 16/32 pitch	7/8-14 O-ring Manifold	185-2100 185-2110	2101 2111	2102 2112	2103 2113	2104 2114	2105 2115	2106 2116	2107 2117	2108 2118	2109 2119
2-Bolt SAE B	1" Keyed	7/8-14 O-ring Manifold	185-2120 185-2130	2121 2131	2122 2132	2123 2133	2124 2134	2125 2135	2126 2136	2127 2137	2128 2138	2129 2139
		6B Splined	7/8-14 O-ring Manifold	185-2140 185-2150	2141 2151	2142 2152	2143 2153	2144 2154	2145 2155	2146 2156	2147 2157	2148 2158
	13T Splined 16/32 pitch	7/8-14 O-ring Manifold	185-2160 185-2170	2161 2171	2162 2172	2163 2173	2164 2174	2165 2175	2166 2176	2167 2177	2168 2178	2169 2179

### Low Speed Valving

MOUNTING	SHAFT	PORT SIZE	DISPL. cm <sup>3</sup> /r [in <sup>3</sup> /r] / PRODUCT NUMBER									
			3.0	4.0	4.9	6.2	8.0	9.6	11.9	14.9	18.7	22.6
2-Bolt	1" Keyed	7/8-14 O-ring Manifold	185-2180 185-2190	2181 2191	2182 2192	2183 2193	2184 2194	2185 2195	2186 2196	2187 2197	2188 2198	2189 2199
		6B Splined	7/8-14 O-ring Manifold	185-2200 185-2210	2201 2211	2202 2212	2203 2213	2204 2214	2205 2215	2206 2216	2207 2217	2208 2218
	13T Splined 16/32 pitch	7/8-14 O-ring Manifold	185-2220 185-2230	2221 2231	2222 2232	2223 2233	2224 2234	2225 2235	2226 2236	2227 2237	2228 2238	2229 2239
4-Bolt	1" Keyed	7/8-14 O-ring Manifold	185-2240 185-2250	2241 2251	2242 2252	2243 2253	2244 2254	2245 2255	2246 2256	2247 2257	2248 2258	2249 2259
		6B Splined	7/8-14 O-ring Manifold	185-2260 185-2270	2261 2271	2262 2272	2263 2273	2264 2274	2265 2275	2266 2276	2267 2277	2268 2278
	13T Splined 16/32 pitch	7/8-14 O-ring Manifold	185-2280 185-2290	2281 2291	2282 2292	2283 2293	2284 2294	2285 2295	2286 2296	2287 2297	2288 2298	2289 2299
2-Bolt SAE B	1" Keyed	7/8-14 O-ring Manifold	185-2300 185-2310	2301 2311	2302 2312	2303 2313	2304 2314	2305 2315	2306 2316	2307 2317	2308 2318	2309 2319
		6B Splined	7/8-14 O-ring Manifold	185-2320 185-2330	2321 2331	2322 2332	2323 2333	2324 2334	2325 2335	2326 2336	2327 2337	2328 2338
	13T Splined 16/32 pitch	7/8-14 O-ring Manifold	185-2340 185-2350	2341 2351	2342 2352	2343 2353	2344 2354	2345 2355	2346 2356	2347 2357	2348 2358	2349 2359

185-2357

Motors with the low speed valving option enable very smooth low speed operation while maintaining high torque.

Designed to run continuously at up to 200 RPM at standard rated

pressures and reduced flows, this option provides smooth operation at low speeds. Furthermore, they resist slippage and have more momentary load holding ability than the standard standard motors.

**Motors with this valving are not intended for low pressure applications (41 Bar [600 PSI] Minimum).**

Shaft side / radial load ratings are not affected by this valving.

For a T Series motor with parking brake configuration not shown in the charts above use the model code system on page B-4-17 to specify the product in detail.



# T Series with Parking Brake (185-)

## Model Code

The following 21-digit coding system has been developed to identify all of the configuration options for the T Series Motor with Parking Brake. Use this model code to specify a motor with the desired features. All 21-digits of the code must be present when ordering. You may want to photocopy the matrix below to ensure that each number is entered in the correct box.

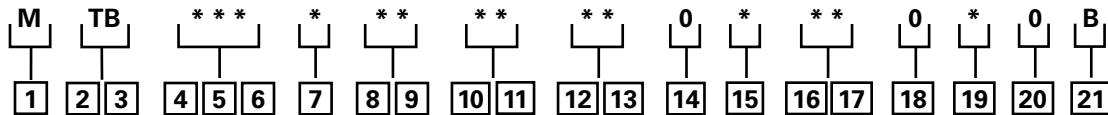

### 1 Product

**M** – Motor

### 2, 3 Series

**T B** – T Series Motor with Parking Brake

### 4, 5, 6 Displacement

**cm<sup>3</sup>/r [in<sup>3</sup>/r]**

**022** - 36 [2.2]  
**030** - 49 [3.0]  
**040** - 66 [4.0]  
**049** - 80 [4.9]  
**062** - 102 [6.2]  
**080** - 131 [8.0]  
**096** - 157 [9.6]  
**119** - 195 [11.9]  
**149** - 244 [14.9]  
**187** - 306 [18.7]  
**226** - 370 [22.6]

### 7 Gerotor/Geroler Options

**A** - Standard  
**B** - Free Running

### 8, 9 Mounting Type

**AA** - 2 Bolt (Standard) 82,6 [3.25] Pilot Dia. and 13,59 [.535] Dia. Mounting Holes on 106,4 [4.19] Dia. B.C.  
**BA** - 4 Bolt (Standard) 44,4 [1.75] Pilot Dia. and 3/8-16 Mounting Holes on 82,6 [3.25] Dia. B.C.  
**DA** - 2 Bolt (Standard) 101,6 [4.00] Pilot Dia. and 14,35 [.565] Dia. Mounting Holes on 146,0 [5.75] Dia. B.C. (SAE B)  
**EA** - 4 Bolt Magneto 82,6 [3.25] Pilot Dia. and 13,59 [.535] Dia. Mounting Holes 106,4 [4.19] Dia. B.C.  
**FA** - 4 Bolt (Standard) 44,4 [1.75] Pilot Dia. and M10 x 1,5-6H Mounting Holes on 82,6 [3.25] Dia. B.C.

### 10, 11 Output Shaft

**01** - 25.4 [1.00] Dia. Straight with Woodruff Key and 1/4-20 Threaded Hole  
**02** - 25.4 [1.00] Dia. SAE 6B Spline with 1/4-20 Threaded Hole  
**16** - 21,74 [.856] Dia. SAE B 13 T Spline  
**18** - 25.4 [1.00] Dia. Tapered with Woodruff Key and Nut  
**24** - 25 [.98] Dia. Straight with 8mm Key and 8mm x 1.2 Threaded Hole  
**27** - 25.4 [1.00] Dia. Straight with Woodruff Key and 1/4-20 Threaded Hole (Plated for Corrosion Pr

### 12, 13 Port Type

**AA** - 7/8 - 14 O-ring  
**AC** - Manifold (5/16-18 Mounting Threads)  
**AE** - G 1/2 (BSP) Straight Thread

### 14 Case Flow Options

**0** - None

### 15 Seal Options

**0** - Standard  
**7** - High Pressure Shaft Seal

### 16, 17 Special Features (Hardware)

**00** - None Specified  
**AB** - Low Speed Valve

### 18 Special Features (Assembly)

**0** - None Specified

### 19 Paint/Packaging Options

**0** - No Paint  
**A** - Painted Low Gloss Black

### 20 Eaton Assigned Code When Applicable

**0** - Assigned Code

### 21 Design Code

**B** - Two (2)

# H, S and T Series (101-, 103-, 158-, 185-)

## Side Load Capacity

The hydrodynamic bearing has infinite life when shaft load ratings are not exceeded. Hence, the shaft side load capacity is more than adequate to handle most externally applied loads (such as belts, chains, etc.), providing the motor to shaft size is applied within its torque rating.

Allowable side load chart, shaft load location drawing and load curves (below) are based on the side / radial loads being applied to shaft at locations A, B, and C, to

determine the shaft side load capacity at locations other than those shown use the formula (shown below).

For more information about shaft side loads on Char-Lynn motors contact your Eaton representative.

**Note:**

When the speed sensor option is used, side load ratings are reduced 25%.

RPM	ALLOWABLE SHAFT SIDE LOAD — KG [LB]		
	A	B	C
900	154 [ 339]	136 [ 300]	118 [ 261]
625	205 [ 452]	181 [ 400]	158 [ 348]
500	256 [ 565]	227 [ 500]	197 [ 435]
400	307 [ 678]	272 [ 600]	237 [ 522]
300	410 [ 904]	363 [ 800]	316 [ 696]
200	718 [1582]	635 [1400]	552 [1216]

$$\text{Sideload } P \text{ kg} = \frac{900}{N} \left( \frac{16800}{L + 96,3} \right) \text{ for 200-900 RPM}$$

$$\text{Sideload } P \text{ [lb]} = \frac{900}{N} \left( \frac{1460}{L + [3.79]} \right) \text{ for 200-900 RPM}$$

Where N = Shaft Speed (RPM)

L = Distance from Mounting Surface

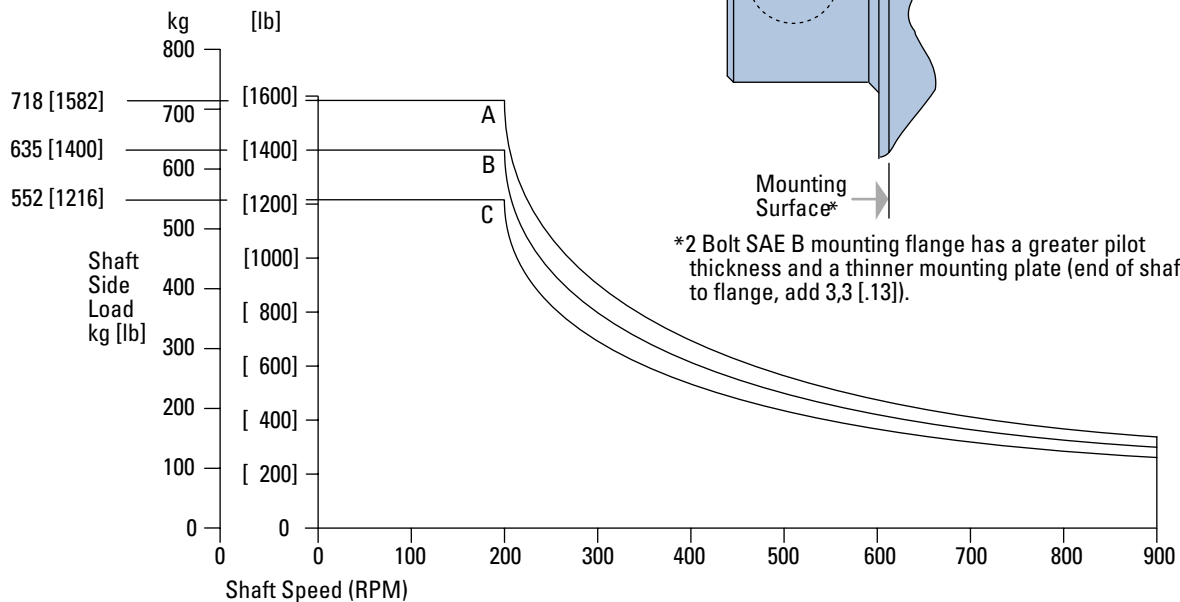

# H, S and T Series (101, 103- 158, 185)

## Dimensions

Shafts

### Shaft Size Motor Torque Combination Limit Guide

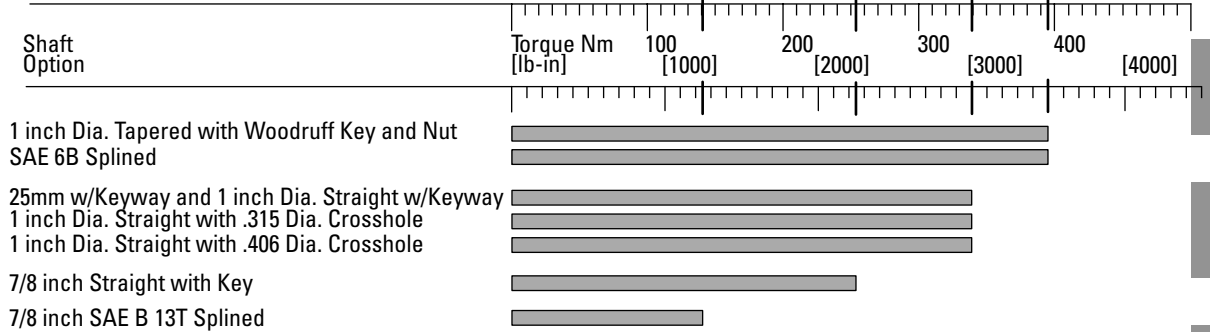

### 1 in. Dia. Straight with Woodruff Key

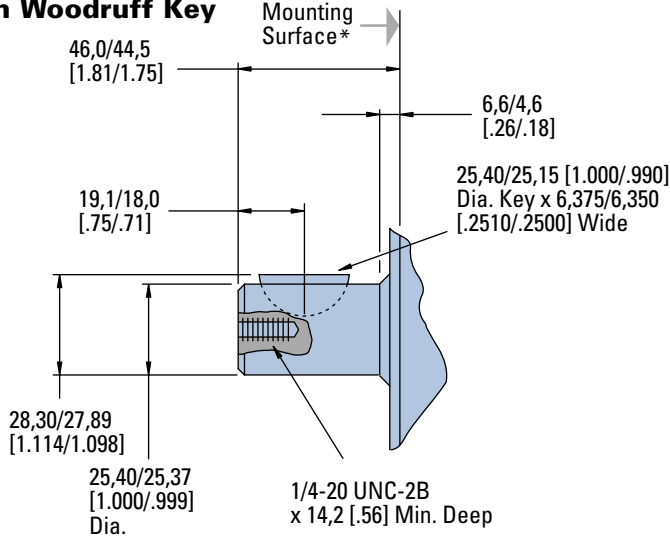

### SAE 6B Splined Shaft

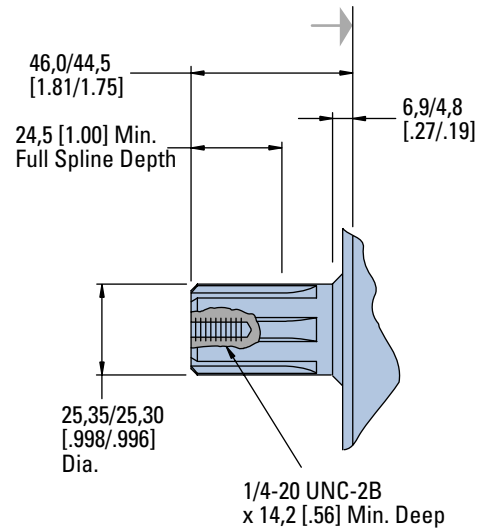

### 1 in. Dia. Straight Shaft with .315 Dia. Crosshole

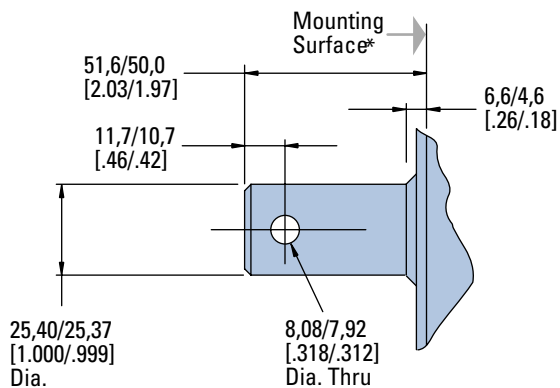

### 1 in. Dia. Straight Shaft with .406 Dia. Crosshole

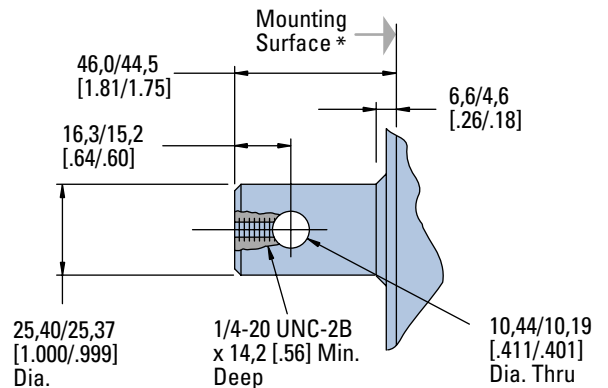

\* 2 Bolt SAE B mounting flange has a greater pilot thickness and a thinner mounting plate (end of shaft to flange, add 3,3 [.13]).

# H, S and T Series (101-, 103- 158-, 185-)

## Dimensions

Shafts

### 1 in. Dia. Tapered Shaft with Woodruff Key and Nut

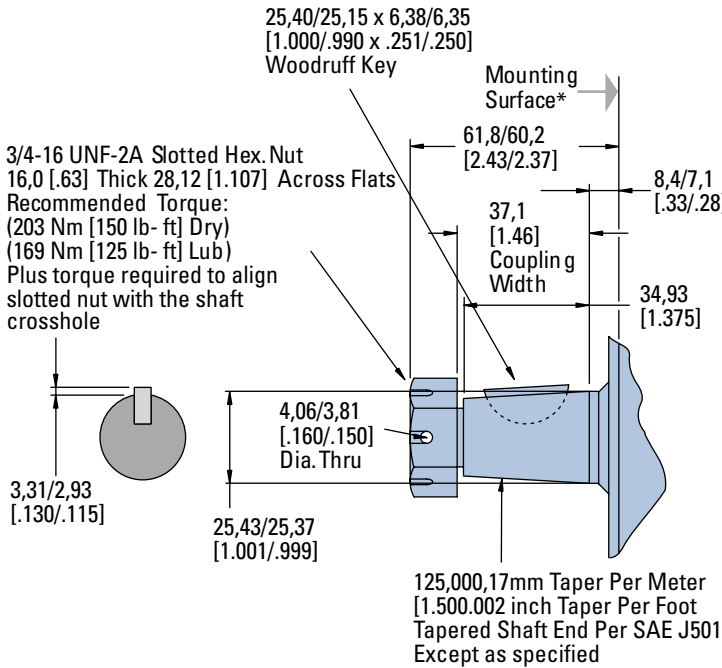

### 25mm Dia. Straight Shaft with 8mm Keyway

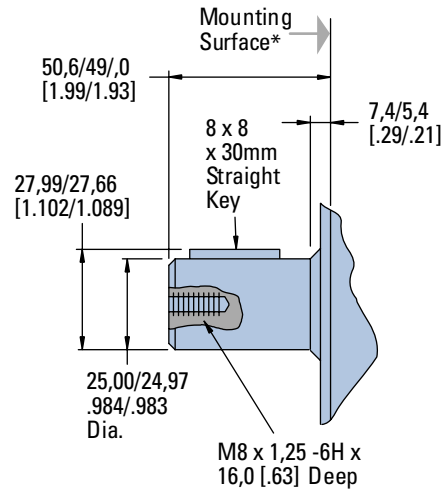

### 7/8 in. Dia. Straight Shaft with Key

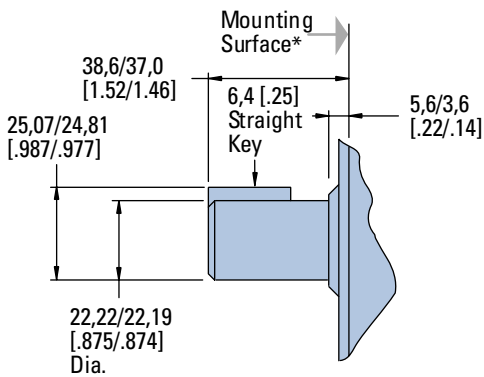

### 7/8 in. Dia. SAE B Shaft 13 T Spline d

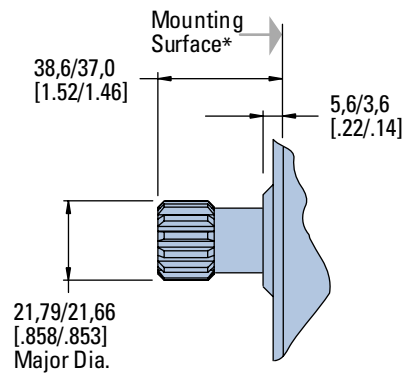

\* 2 Bolt SAE B mounting flange has a greater pilot thickness and a thinner mounting plate (end of shaft to flange, add 3,3 [.13]).

# H, S and T Series (101-, 103- 158-, 185-)

## Mounting Options

**Note:**

Mounting Surface Flatness Requirement is ,13 mm [.005 inch] Max.

### 4 Bolt Magneto

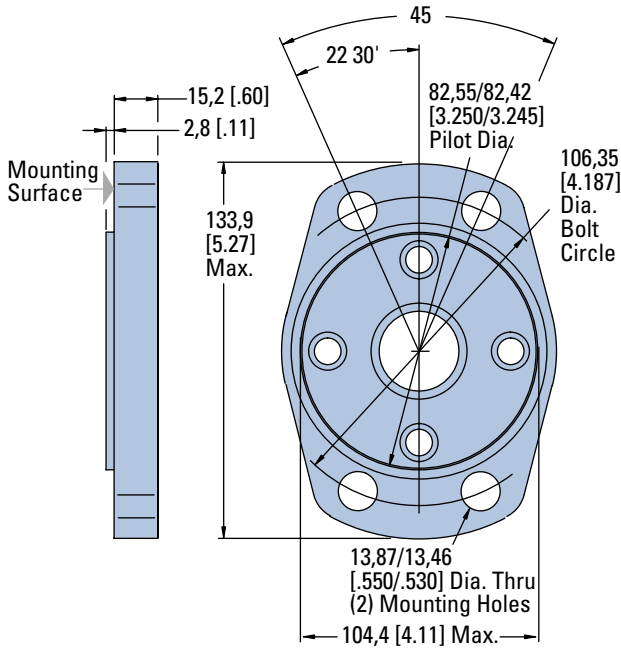

### 2 Bolt SAE B

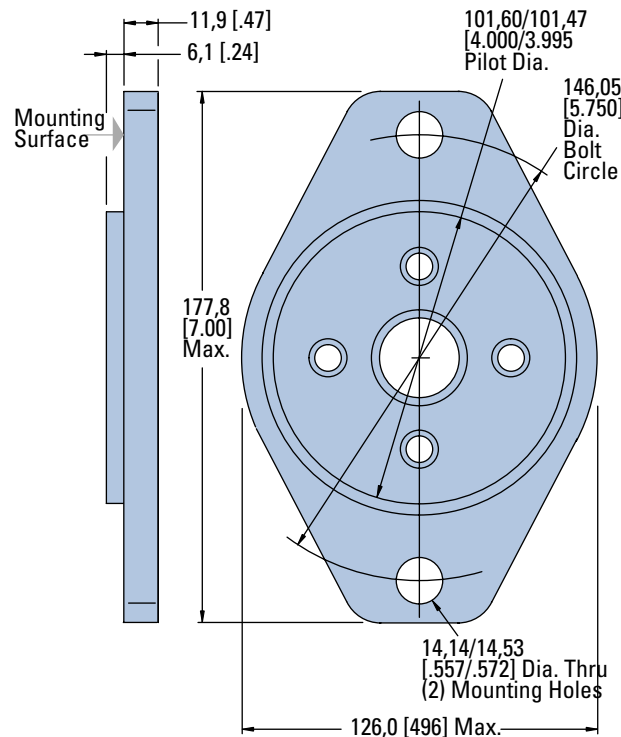

### Base Block Mounting Kits

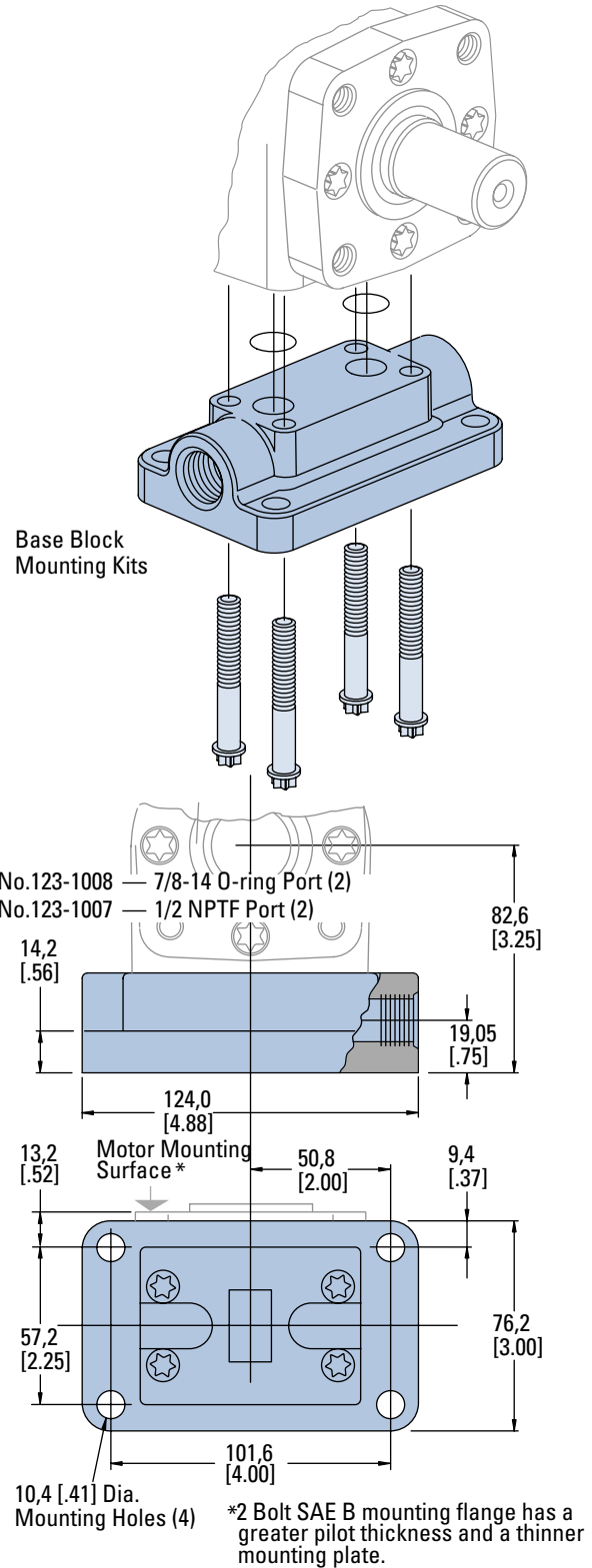

# H, S and T Series (101-, 103-, 158-, 185-)

## Dimensions

Ports

### Ports

End Ports — H Series only  
G 1/2 (BSP) (2)  
or 3/4-16 O-ring (2)

### Standard Rotation Viewed from Drive End

Port A Pressurized — CW  
Port B Pressurized — CCW

7/8-14 ports

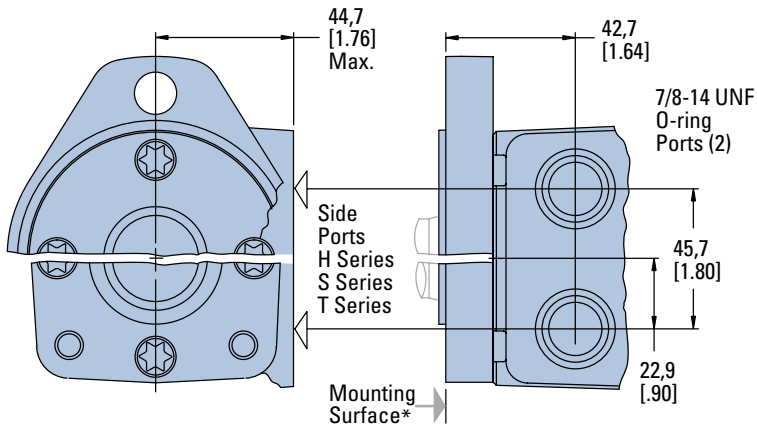

End Ports (H Series only)

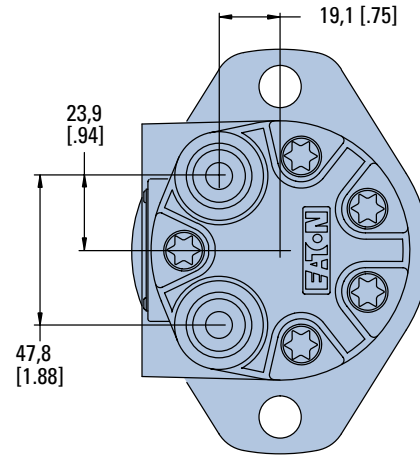

Use of Teflon Tape Sealant/  
Lubricant (with 1/2 14 NPTF  
Port Connectors only).

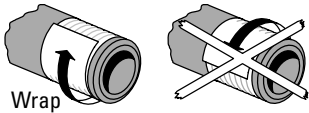

When using fittings with  
Teflon tape, be careful when  
taping and tightening. Over  
tightening or improperly  
taped fittings can cause  
damage to housing or  
leakage.

6-1/2 or 1/2 NPTF ports

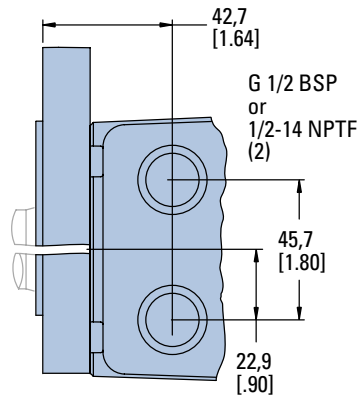

Manifold Ports

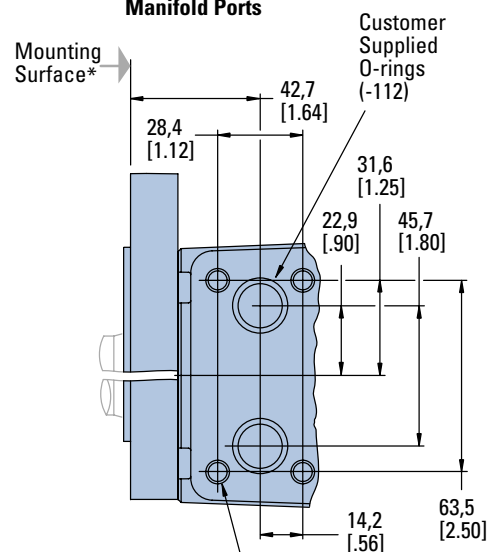

Manifold Ports w/manifold case port

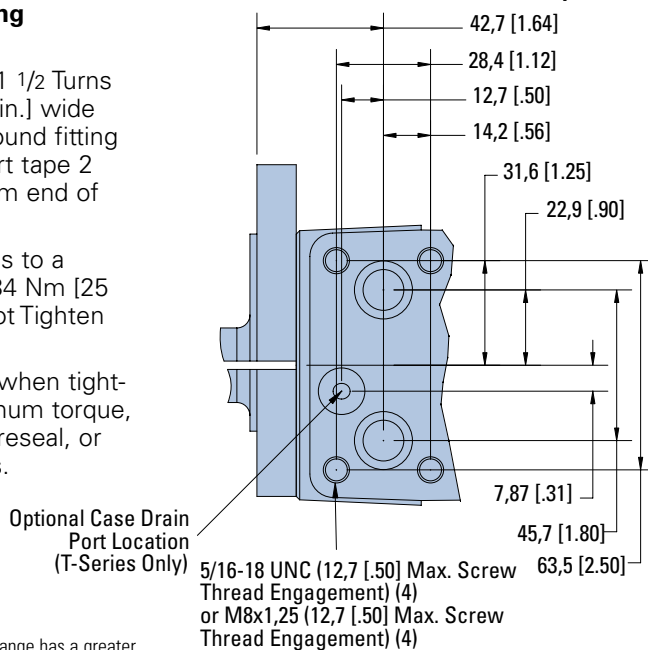

### Use the following procedures:

- Wrap approx. 1 1/2 Turns of 13 mm [1/2 in.] wide Teflon Tape around fitting threads — start tape 2 threads up from end of fitting.
- Tighten threads to a Maximum of 34 Nm [25 lb-ft]. — Do Not Tighten Further —
- If fittings leak when tightened to maximum torque, either retape, reseal, or replace fittings.

### Note:

End ported motor option is derated to 1400 continuous, 1700 psi intermittent.

\*2 Bolt SAE B mounting flange has a greater pilot thickness and a thinner mounting plate.

# W Series (162-)

## Highlights

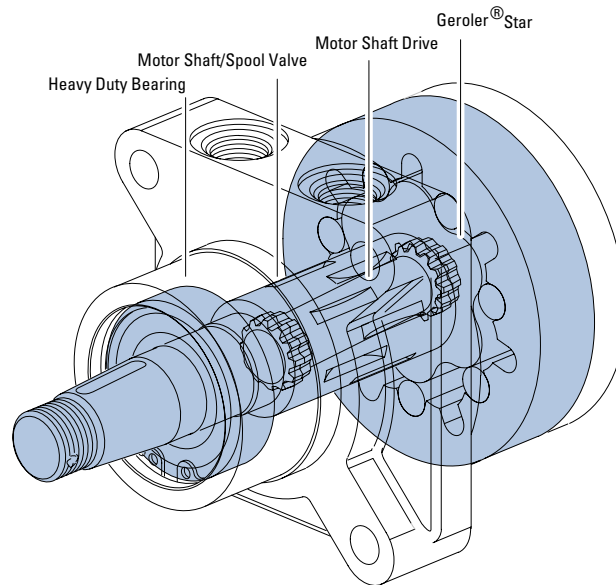

### Features:

- Heavy duty bearing
- Wheel drive interface
- Three-pressure zone design (ability to reduce case pressure)
- Variety of displacements, shafts, mounts and special options
- Special options to meet customer needs

### Benefits:

- High side-load capacity
- High shock load capability
- Wheel mount interface
- Compact powerful package
- High efficiency
- Smooth low-speed operation
- Extended leak-free performance

### Applications:

- Scissors lifts
- Boom lifts
- Mid-size ZTR mowers
- Turf equipment
- Greens mowers
- Sand trap rakes
- Railroad maintenance equipment
- Industrial sweepers and floor polishers
- Skid steer attachments
- Many more

### Description

Char-Lynn W Series motors with the Geroler displacement element offer the same low friction and long-life advantages as the S and T Series.

The W Series features the simplicity of Eaton's proven spool valve and a Geroler element that provides superior drive life and smooth performance. In addition, this motor has a rugged housing with an extra large capacity side load bearing.

### W Series Motors

Geroler Element	7 Displacements
Flow l/min [GPM]	68 [18] Continuous*** 76 [20] Intermittent**
Speed	288 RPM
Pressure bar [PSI]	165 [2400] Cont.*** 179 [2600] Inter.**
Torque Nm [lb-in]	410 [3624] Cont.*** 562 [4970] Inter.**

\*\*\* Continuous— (Cont.) Continuous rating, motor may be run continuously at these ratings.

\*\* Intermittent— (Inter.) Intermittent operation, 10% of every minute.



Scissor Lift



Sweeper



Trencher



Boom Lift



# W Series (162-)

## Specifications

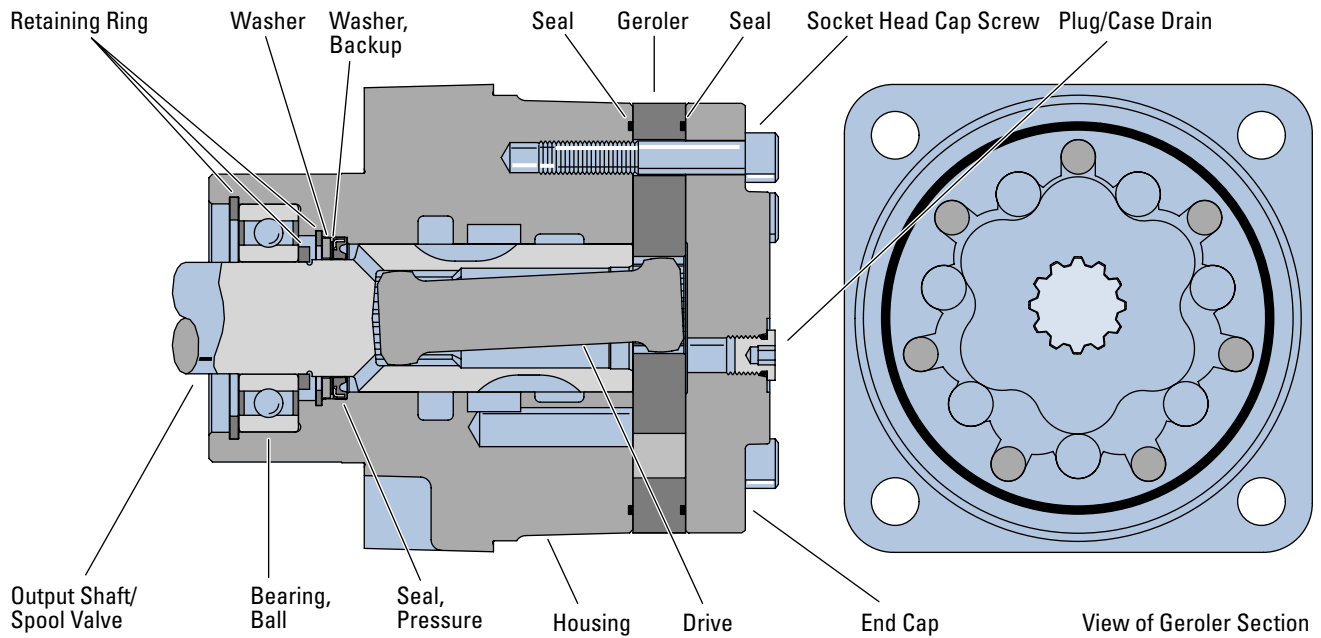

### SPECIFICATION DATA — W SERIES MOTORS

Displ. cm <sup>3</sup> /r [in <sup>3</sup> /r]		80 [4.9]	126 [7.7]	154 [9.4]	195 [11.9]	251 [15.3]	303 [18.5]	374 [22.8]
Max. Speed (RPM)		267	288	214	200	200	200	200
Flow l/min [GPM]	Continuous	23 [6]	30 [8]	34 [9]	38 [10]	53 [14]	62 [16.5]	68 [18]
	Intermittent	23 [6]	30 [8]	34 [9]	38 [10]	53 [14]	62 [16.5]	76 [20]
Theo. Torque	Continuous	176 [1555]	279 [2470]	318 [2813]	318 [2816]	375 [3319]	387 [3429]	410 [3624]
	Intermittent	189 [1676]	298 [2640]	373 [3301]	439 [3882]	548 [4849]	539 [4769]	562 [4970]
Pressure	Continuous	165 [2400]	165 [2400]	152 [2200]	124 [1800]	110 [1600]	97 [1400]	83 [1200]
$\Delta$ bar [ $\Delta$ PSI]	Intermittent	179 [2600]	179 [2600]	179 [2600]	179 [2600]	165 [2400]	138 [2000]	124 [1800]

#### Note:

To assure best motor life, run motor for approximately one hour at 30% of rated pressure before application to full load. Be sure motor is filled with fluid prior to any load applications.

#### Maximum Inlet Pressure:

179 bar [2600 PSI]  
Do Not Exceed  $\Delta$  Pressure Rating (for displacement size see chart above).

#### Return Pressure (Back-Pressure):

Do not exceed  $\Delta$  pressure rating (see chart above). Case drain required.

#### Note:

Optional version can be used without case drain.

#### Case Pressure:

Minimum – No Pressure  
Maximum – 103 bar [1500 PSI] without case drain.

#### Note:

The case must be flooded when the motor is operating.

#### $\Delta$ Pressure:

The true  $\Delta$  bar [ $\Delta$  PSI] between inlet port and return port

#### Continuous Rating:

Motor may be run continuously at these ratings

#### Intermittent Operation:

10% of every minute

#### Recommended Fluids:

Premium quality, anti-wear type hydraulic oil with a viscosity of not less than 70 SUS at operating temperature.

#### Recommended Maximum System Operating Temp.:

82°C [180°F]

#### Recommended Filtration:

per ISO Cleanliness Code, level 20/18/13



# W Series (162-)

## Performance Data

Motors run with high efficiency in all areas designated with a number for torque and speed. For best motor life select a motor to run with a torque and speed range shown in the light shaded area.

Performance data is typical at 120 SUS. Actual data may vary slightly from motor to motor in production.

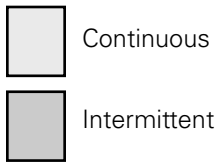

### 80 cm<sup>3</sup>/r [4.9 in<sup>3</sup>/r]

Δ Pressure bar [PSI]

Continuous

		[400]	[600]	[800]	[1000]	[1200]	[1400]	[1600]	[1800]	[2000]	[2200]	[2400]	[2600]
		28	41	55	69	83	97	110	124	138	152	165	179
Flow /min [GPM]	[2]	[204]	[337]	[474]	[612]	[748]	[883]	[1019]	[1149]	[1281]	[1412]	[1540]	[1610]
	<b>7.6</b>	23 93	38 89	54 88	69 84	85 83	100 79	115 73	130 69	145 69	160 61	174 56	182 39
	[4]	[223]	[357]	[489]	[627]	[769]	[902]	[1035]	[1169]	[1295]	[1424]	[1555]	[1676]
<b>15.1</b>	25 178	40 172	55 170	71 168	87 165	102 159	117 157	132 154	146 146	161 142	176 131	189 117	
[6]	[255]	[342]	[477]	[612]	[749]	[879]	[1014]	[1154]	[1286]	[1408]	[1533]	[1648]	
<b>22.7</b>	29 267	39 265	54 262	69 258	85 257	99 252	115 248	130 241	145 235	159 229	173 219	186 206	

### 126 cm<sup>3</sup>/r [7.7 in<sup>3</sup>/r]

Δ Pressure bar [PSI]

Continuous

		[400]	[600]	[800]	[1000]	[1200]	[1400]	[1600]	[1800]	[2000]	[2200]	[2400]	[2600]
		28	41	55	69	83	97	110	124	138	152	165	179
Flow /min [GPM]	[2]	[390]	[605]	[817]	[1032]	[1248]	[1448]	[1656]	[1871]	[2069]	[2243]	[2414]	[2513]
	<b>7.6</b>	44 58	68 56	92 55	117 51	141 49	164 45	187 43	211 41	234 33	253 32	273 26	284 17
	[4]	[382]	[605]	[817]	[1036]	[1252]	[1463]	[1694]	[1908]	[2113]	[2306]	[2470]	[2640]
<b>15.1</b>	43 113	68 106	92 106	117 104	141 93	165 97	191 94	216 88	239 82	261 79	279 74	298 60	
[6]	[367]	[587]	[802]	[1017]	[1236]	[1444]	[1668]	[1882]	[2091]	[2284]	[2459]	[2637]	
<b>22.7</b>	41 172	66 167	91 164	115 161	140 156	163 152	188 147	213 141	236 134	258 130	278 120	298 103	
[8]	[346]	[561]	[769]	[981]	[1203]	[1419]	[1634]	[1849]	[2039]	[2217]	[2432]	[2633]	
<b>30.3</b>	39 228	63 225	87 220	111 216	136 213	160 208	185 201	209 195	230 188	250 174	275 163	297 149	

### 154 cm<sup>3</sup>/r [9.4 in<sup>3</sup>/r]

Δ Pressure bar [PSI]

Continuous

		[400]	[600]	[800]	[1000]	[1200]	[1400]	[1600]	[1800]	[2000]	[2200]	[2400]	[2600]
		28	41	55	69	83	97	110	124	138	152	165	179
Flow /min [GPM]	[2]	[450]	[723]	[989]	[1249]	[1512]	[1769]	[2021]	[2269]	[2502]	[2714]	[2904]	[3019]
	<b>7.6</b>	51 47	82 47	112 46	141 44	171 40	200 39	228 36	256 33	283 30	307 26	328 19	341 10
	[4]	[470]	[737]	[1009]	[1276]	[1540]	[1802]	[2064]	[2323]	[2570]	[2813]	[3019]	[3242]
<b>15.1</b>	53 94	83 93	114 90	144 89	174 87	204 84	233 81	262 78	290 73	318 67	341 65	366 52	
[6]	[435]	[715]	[984]	[1252]	[1513]	[1787]	[2020]	[2274]	[2521]	[2812]	[3042]	[3301]	
<b>22.7</b>	49 143	81 140	111 138	141 137	171 134	202 131	228 128	257 124	285 117	318 112	344 103	373 91	
[8]	[407]	[677]	[945]	[1214]	[1477]	[1740]	[2005]	[2260]	[2503]	[2735]	[2964]	[3206]	
<b>30.3</b>	46 190	76 188	107 186	137 184	167 182	197 179	227 176	255 171	283 166	309 158	335 148	361 137	
[9]	[380]	[648]	[914]	[1183]	[1452]	[1714]	[1981]	[2243]	[2499]	[2733]	[2964]	[3195]	
<b>34</b>	43 214	73 212	103 210	134 207	164 206	194 202	224 200	253 196	282 191	309 182	335 173	361 162	

### 195 cm<sup>3</sup>/r [11.9 in<sup>3</sup>/r]

Δ Pressure bar [PSI]

Continuous

		[400]	[600]	[800]	[1000]	[1200]	[1400]	[1600]	[1800]	[2000]	[2200]	[2400]	[2600]
		28	41	55	69	83	97	110	124	138	152	165	179
Flow /min [GPM]	[2]	[478]	[827]	[1171]	[1511]	[1839]	[2153]	[2452]	[2756]	[3027]	[3275]	[3513]	[3673]
	<b>7.6</b>	54 38	93 38	132 37	171 36	208 35	243 34	277 34	311 30	342 29	370 26	397 22	415 16
	[4]	[515]	[872]	[1220]	[1558]	[1886]	[2206]	[2518]	[2816]	[3107]	[3382]	[3647]	[3882]
<b>15.1</b>	58 75	99 73	138 73	176 71	213 70	249 69	284 66	318 64	351 62	382 56	412 52	439 44	
[6]	[524]	[878]	[1214]	[1551]	[1875]	[2199]	[2518]	[2824]	[3113]	[3389]	[3666]		
<b>22.7</b>	59 114	99 111	137 111	175 110	212 108	248 106	284 105	319 103	352 99	383 95	414 91		
[8]	[518]	[856]	[1187]	[1524]	[1861]	[2187]	[2499]	[2782]	[3064]	[3334]			
<b>30.3</b>	59 151	97 150	134 150	172 149	210 147	247 145	282 144	314 143	346 141	377 136			
[10]	[462]	[797]	[1133]	[1468]	[1799]	[2118]	[2442]	[2739]	[3023]	[3281]			
<b>38</b>	52 190	90 188	128 187	166 186	203 184	239 184	276 182	309 179	342 176	371 160			

[3673] } Torque [lb-in]  
415 }  
16 } Speed RPM

# W Series (162-)

## Performance Data

Motors run with high efficiency in all areas designated with a number for torque and speed. For best motor life select a motor to run with a torque and speed range shown in the light shaded area.

Performance data is typical at 120 SUS. Actual data may vary slightly from motor to motor in production.

### 251 cm<sup>3</sup>/r [15.3 in<sup>3</sup>/r]

Δ Pressure bar [PSI]



Continuous

	[400] 28	[600] 41	[800] 55	[1000] 69	[1200] 83	[1400] 97	[1600] 110	[1800] 124	[2000] 140	[2200] 152	[2400] 165
[2] <b>7.6</b>	[759] 86 30	[1194] 135 29	[1683] 190 29	[2122] 240 28	[2535] 286 27	[2928] 331 27	[3319] 375 25	[3634] 411 22	[3946] 446 17	[4242] 479 15	[4553] 514 14
[4] <b>15.1</b>	[806] 91 59	[1257] 142 58	[1691] 191 58	[2130] 241 56	[2563] 290 55	[2988] 338 55	[3381] 382 52	[3799] 429 48	[4147] 469 47	[4515] 510 41	[4849] 548 40
[6] <b>22.7</b>	[780] 88 90	[1219] 138 88	[1646] 186 87	[2084] 235 86	[2515] 284 85	[2933] 331 83	[3336] 377 83	[3716] 420 79			
[8] <b>30.3</b>	[720] 81 120	[1148] 130 118	[1590] 180 117	[2029] 229 117	[2449] 277 114	[2861] 323 112	[3236] 366 111	[3627] 410 108			
[10] <b>37.9</b>	[645] 73 148	[1080] 122 147	[1513] 171 147	[1947] 220 145	[2371] 268 145	[2779] 314 143	[3151] 356 141	[3515] 397 137			
[12] <b>45.4</b>	[557] 63 178	[992] 112 177	[1428] 161 176	[1864] 211 174	[2292] 259 174	[2697] 305 172	[3087] 349 169				
[14] <b>53.0</b>	[460] 52 208	[888] 100 206	[1330] 150 206	[1761] 199 203	[2191] 248 202	[2615] 295 200	[3035] 343 197				

### 303 cm<sup>3</sup>/r [18.5 in<sup>3</sup>/r]

Δ Pressure bar [PSI]

Continuous

 Continuous  
 Intermittent

	[400] 28	[600] 41	[800] 55	[1000] 69	[1200] 83	[1400] 97	[1600] 110	[1800] 124	[2000] 140
[2] <b>7.6</b>	[920] 104 24	[1454] 164 24	[1974] 223 24	[2480] 280 23	[2969] 335 22	[3429] 387 22	[3859] 436 20	[4230] 478 18	[4583] 518 16
[4] <b>15.1</b>	[960] 108 49	[1487] 168 49	[2007] 227 47	[2513] 284 47	[3006] 340 46	[3457] 391 45	[3905] 441 44	[4338] 490 41	[4769] 539 39
[6] <b>22.7</b>	[911] 103 73	[1445] 163 73	[1961] 222 72	[2473] 279 71	[2952] 334 71	[3411] 385 69	[3842] 434 68	[4276] 483 66	
[8] <b>30.3</b>	[843] 95 99	[1375] 155 98	[1888] 213 97	[2393] 270 96	[2886] 326 95	[3350] 379 94	[3763] 425 93		
[10] <b>37.9</b>	[752] 85 123	[1274] 144 122	[1789] 202 122	[2303] 260 120	[2792] 316 119	[3274] 370 119	[3650] 412 118		
[12] <b>45</b>	[652] 74 148	[1170] 132 147	[1691] 191 146	[2199] 248 145	[2691] 304 145	[3123] 353 144			
[14] <b>53</b>	[526] 59 172	[1039] 117 172	[1560] 176 171	[2064] 233 170	[2548] 288 169	[2999] 339 168			
[16.5] <b>62</b>	[353] 40 203	[864] 98 203	[1367] 154 201	[1876] 212 200	[2369] 268 200				

[4583]  
518 } Torque [lb-in]  
16 } Nm  
Speed RPM

### 374 cm<sup>3</sup>/r [22.8 in<sup>3</sup>/r]

Δ Pressure bar [PSI]

Continuous

	[400] 28	[600] 41	[800] 55	[1000] 69	[1200] 83	[1400] 97	[1600] 110	[1800] 124
[2] <b>7.6</b>	[1086] 123 20	[1753] 198 19	[2365] 267 17	[2960] 334 16	[3533] 399 14	[4025] 455 12	[4484] 507 12	[4970] 562 11
[4] <b>15.1</b>	[1152] 130 39	[1797] 203 39	[2431] 275 38	[3048] 344 36	[3624] 409 34	[4129] 467 33	[4599] 520 31	
[6] <b>22.7</b>	[1099] 124 60	[1749] 198 58	[2377] 269 57	[2996] 339 56	[3557] 402 54	[4077] 461 53		
[8] <b>30.3</b>	[1018] 115 80	[1662] 188 79	[2290] 259 78	[2894] 327 76	[3440] 389 75	[3952] 447 74		
[10] <b>37.9</b>	[940] 106 100	[1582] 179 99	[2210] 250 97	[2812] 318 96	[3346] 378 95	[3816] 431 95		
[12] <b>45.4</b>	[809] 91 120	[1454] 164 119	[2077] 235 117	[2677] 302 116	[3216] 363 115			
[14] <b>53.0</b>	[648] 73 141	[1284] 145 139	[1907] 215 138	[2506] 283 137	[3033] 343 137			
[16] <b>60.6</b>	[485] 55 160	[1107] 125 159	[1722] 195 157	[2315] 262 157	[2838] 321 157			
[18] <b>68.1</b>	[307] 35 180	[930] 105 179	[1543] 174 178	[2133] 241 178				
[20] <b>75.7</b>	[111] 13 201	[730] 82 199	[1342] 152 198	[1939] 219 197				

# W Series (162-)

## Dimensions

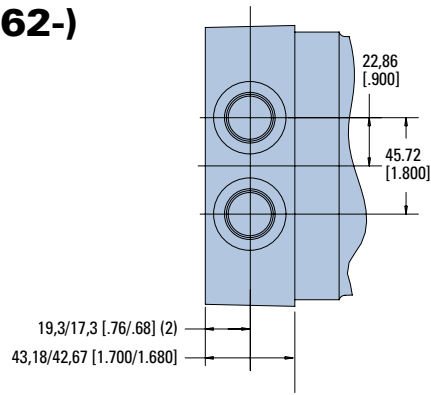

### Ports

- 7/8-14 SAE O-Ring Ports
- G1/2 BSP Straight Thread Port
- Manifold (15/16-18 Mounting Threads)

### Standard Rotation Viewed from Shaft End

- Port A Pressurized — CW
- Port B Pressurized — CCW

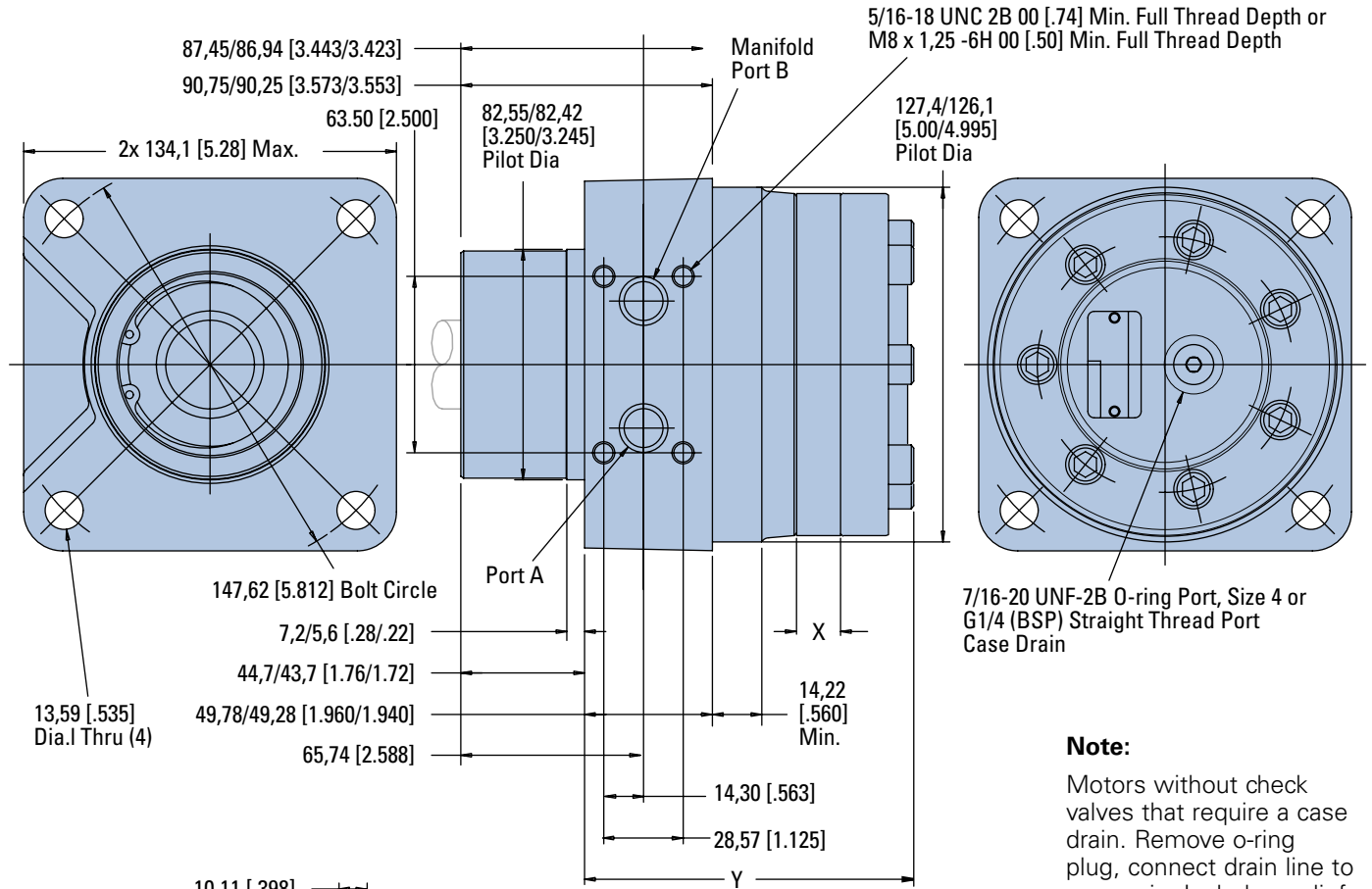

7/16-20 UNF-2B O-ring Port, Size 4 or G1/4 (BSP) Straight Thread Port Case Drain

### Note:

Motors without check valves that require a case drain. Remove o-ring plug, connect drain line to reservoir. Include a relief valve (in the drain line) set to maintain 3,4 bar [50 PSI] motor case pressure.

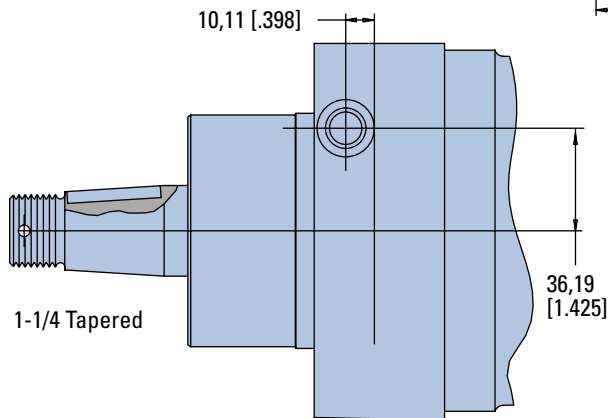

### W SERIES DIMENSIONS

Displacement cm <sup>3</sup> /r [in <sup>3</sup> /r]	X mm [inch]	Y mm [inch]
80 [4.9]	9,1 [.36]	116,6 [4.59]
126 [7.7]	11,9 [.47]	119,6 [4.71]
154 [9.4]	14,7 [.58]	122,2 [4.81]
195 [11.9]	18,5 [.73]	126,2 [4.97]
251 [15.3]	23,9 [.94]	131,6 [5.18]
303 [18.5]	29,0 [1.14]	136,4 [5.37]
374 [22.8]	35,6 [1.40]	143,3 [5.64]

# W Series (162-)

## Dimensions Shafts

Recommended Torque:  
(373 Nm [275 lb-ft] Dry)  
(305 Nm [225 lb-ft] Lub) Plus  
Torque required to align the  
slotted nut with the Shaft  
Crosshole.

### 1 1/4 Tapered

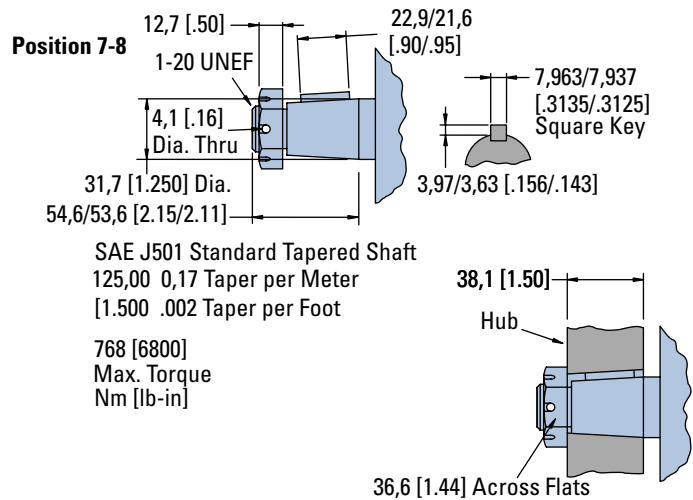
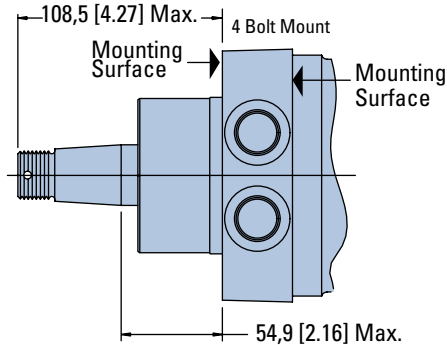

### 1 1/4 Inch Straight

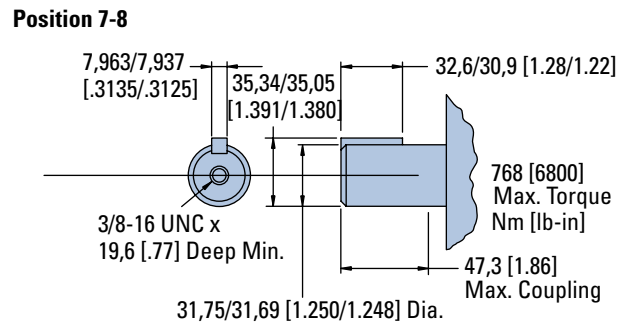
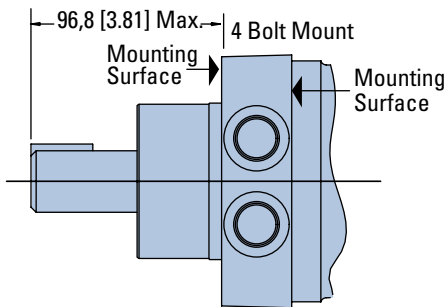

### 32 mm Straight

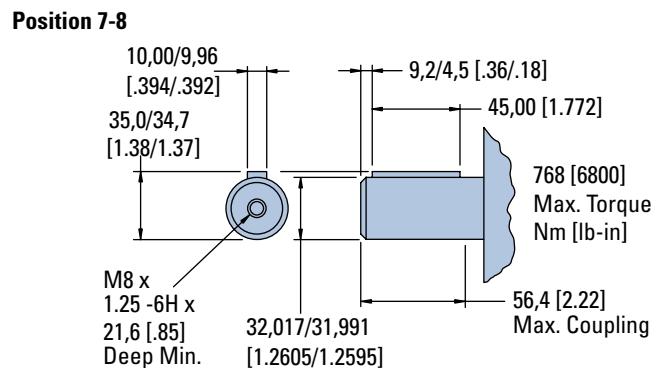
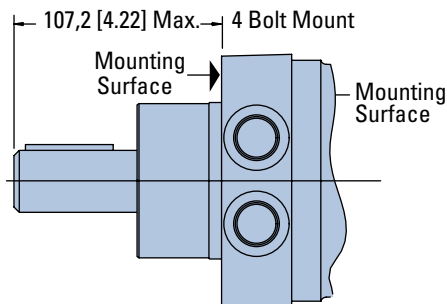

### 1 1/4 14 Tooth Splined

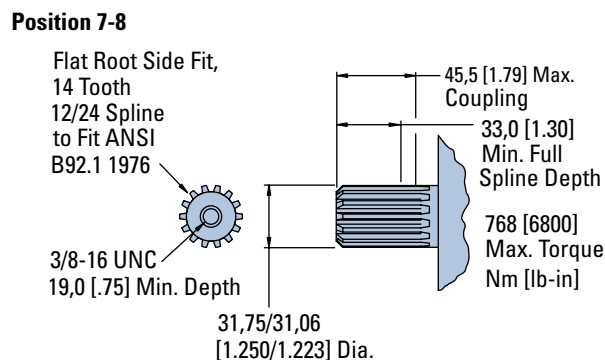
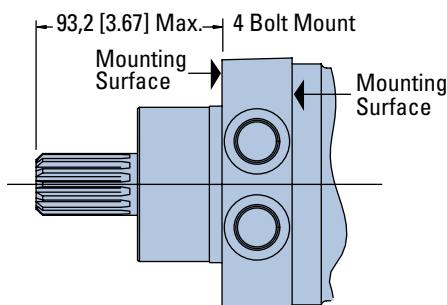

# W Series (162-)

## Side Load Capacity

- Case pressure needs to be added to the outward axial thrust load and subtracted from inward axial thrustload – Case Pressure bar x 87, 1 [PSI x 1.35]
- Life values in Chart A can be adjusted for speeds up to 200 rpm.  

$$\frac{\text{Life value} \times 100 \text{ rpm}}{\text{application rpm}}$$
- Shaded areas  are intermittent loading.
- To convert application radial load at any load location to side load at the center of keyway multiply by the application factor from Chart B.

**Example:**

Side Load: 4849 N @ 120 mm [1090 lbf @ 4.75 inch] from flange. Average Thrust Load: 890 N [200 lbf] inward (toward motor).  
 Case Pressure: 66 bar [960 PSI].  
 Average Speed: 150 rpm.

Expected Life Calculation: Adjust side load value (due to load variation): from Chart B look at 120mm [4.75 inch] read at angled curve for load adjustment factor of 1.38.

Adjusted load is: (4849 N [1090 lbf]) x (1.38) = 6690 N [1504 lbf]

Thrust Load Value (due to case pressure):  
 (960 PSI) x (1.35) = [1296 lbf]  
 (66 bar) x (87, 1) = 5750 N

Average thrust load found to be 890 N [200 lbf] inwards so subtract from thrust load due from case pressure:

5750 N - 890 N = 4860 N or  
 [1296 lbf] - 200 lbf = [1096 lbf]

Read Life Expectancy from Chart A: Value from chart reading across top to 6672 [1500] (6090 N [1504 lbf]) and down left side to 4895 [1100] (4875 N [1096 lbf])

Life = 1800 Hours

Speed Adjustment for over 100 rpm:  

$$\frac{(1800 \text{ hrs}) \times (100 \text{ rpm})}{150 \text{ rpm}} = 1200 \text{ Hours}$$

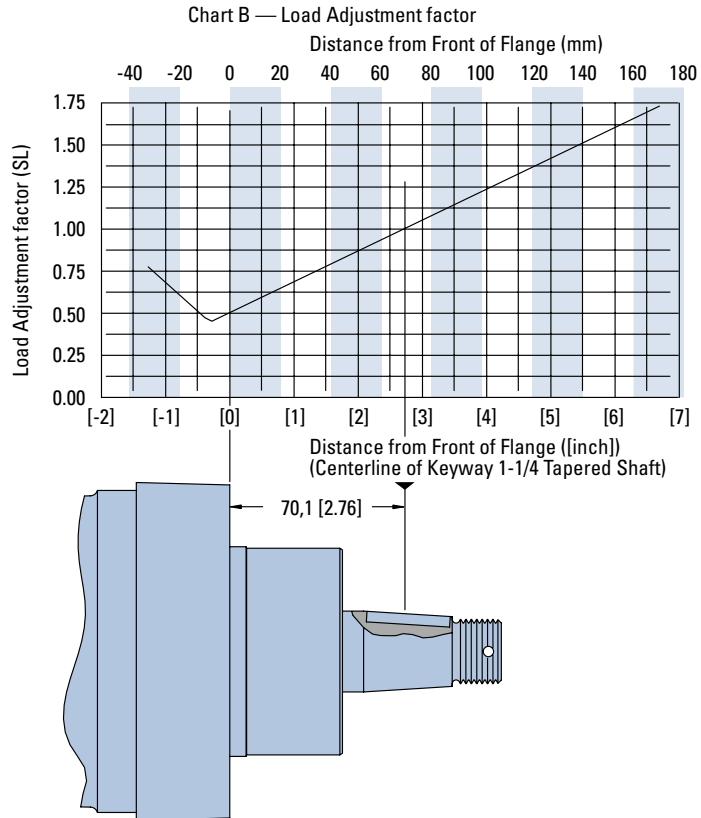

**CHART A — EXPECTED B10 LIFE (HOURS) OF BEARING UNDER VARIOUS LOADS**

Axial Thrust		Radial Load at Centerline of keyway at 100 RPM								
N	lbf]	1110 [250]	2225 [500]	3335 [750]	4450 [1000]	4560 [1250]	6670 [1500]	7785 [1750]	8895 [2000]	11120 [2500]
445	[100]	410 600	66 000	19 600	8 300	4 200	2 400	1 500	1 000	
1335	[300]	92 700	40 900	19 600	8 300	4 200	2 400	1 500	1 000	
2225	[500]	39 400	20 900	12 400	7 900	4 200	2 400	1 500	1 000	
3115	[700]	21 400	12 600	8 100	5 500	3 900	2 400	1 500	1 000	
4005	[900]	13 300	8 400	5 700	4 000	2 900	2 200	1 500	1 000	
4895	[1100]	9 000	6 000	4 200	3 100	2 300	1 800	1 400	1 000	
5785	[1300]	6 500	4 500	3 200	2 400	1 900	1 500	1 200	900	
6670	[1500]	4 800	3 500	2 600	2 000	1 500	1 200	1 000		
7560	[1700]	3 700	2 800	2 100	1 600	1 300				
8450	[1900]	3 000	2 200							
8895	[2000] Max. Thrust									

# W Series (162-)

## Model Code

The following 16-digit coding system has been developed to identify all of the configuration options for the W Series motor. Use this model code to specify a motor with the desired features. All 16-digits of the code must be present when ordering. You may want to photocopy the matrix below to ensure that each number is entered in the correct box.

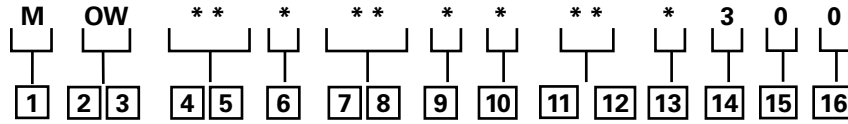

### 1 Product

M – Motor

### 2, 3 Series

OW – W Series

### 4, 5 Displacement cm<sup>3</sup>/r [in<sup>3</sup>/r]

05 – 30 [4.9]

08 – 126 [7.7]

09 – 154 [9.4]

12 – 195 [11.9]

15 – 251 [15.3]

19 – 303 [18.5]

23 – 374 [22.8]

### 6 Mounting Type

B – 4 Bolt (Wheel) 82,6 [3.25] Pilot Dia. and 13,59 [.535] Dia. Mounting Holes 147,6 [5.81] Dia., B.C., 127,0 [5.00] rear pilot

### 7, 8 Output Shaft

02 – 1 1/4 inch Dia. Flat Root Side Fit, 14 Tooth, 12/24 DP 30° Involute Spline with 3/8-16 UNC-2B Thread in End, 33,0 [1.30] Min. Full Spline

03 – 1 1/4 inch Dia. .125:1 Tapered Shaft Per SAE J501 with 1–20 UNEF -2A Threaded Shaft End and Slotted Hex Nut, 7,938 [.3125] Square x 22,22 [.875] Straight Key

04 – 32mm Dia. Straight Shaft with M8 x 1, 25-6H Thread in End, 9,982 [.3930] Wide x 7,995 [.3132] High x 45,00 [1.772] Long Key

06 – 1 1/4 inch Dia. Straight Shaft with 3/8 – 16 UNC 2B Thread in End, 7,938 [.3125] Square x 34,92 [1.375] Straight Key

### 9 Ports

A – 7/8 -14 UNF - 2B SAE O-ring Port

B – G 1/2 (BSP) Straight Thread Port

### 10 Case Flow Options

A – 7/16 - 20 UNF - 2B SAE O-ring Port

B – G 1/4 (BSP) Straight Thread Port

C – Internal Check Valve

### 11, 12 Special Features (Hardware)

00 – None

01 – Viton Seals

### 13 Special Features (Assembly)

0 – None

1 – Reverse Rotation

### 14 Paint/Special Packaging

0 – No Paint, Individual Box

A – Painted Low Gloss Black, Bulk Box Option

### 15 Eaton Assigned Code when Applicable

0 – Assigned Code

### 16 Eaton Assigned Design Code

C – Assigned Design Code

# W Series with Parking Brake (162-)

## Dimensions

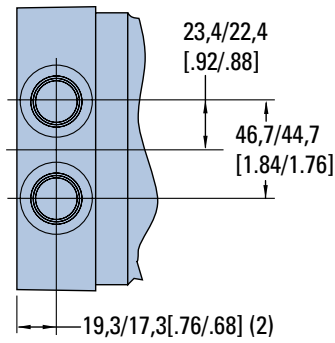

## Ports

7/8 -14 UNF 2B SAE O-ring Ports (2) or  
G 1/2 (BSP) Straight Thread

## Standard Rotation Viewed from Shaft End

Port A Pressurized — CW

Port B Pressurized — CCW

## Port Dimensions

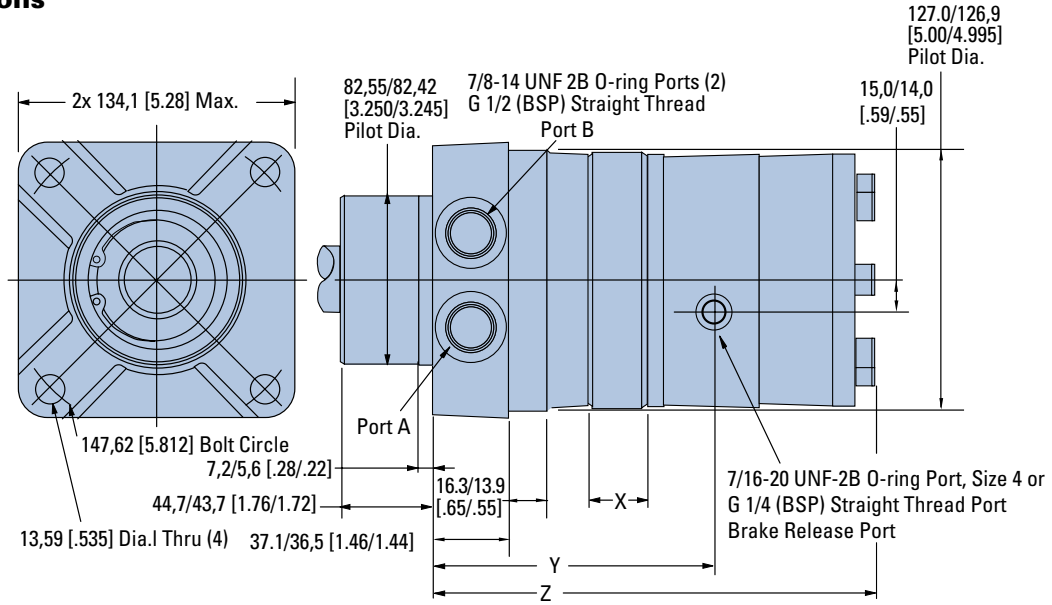

## Mounting Dimensions

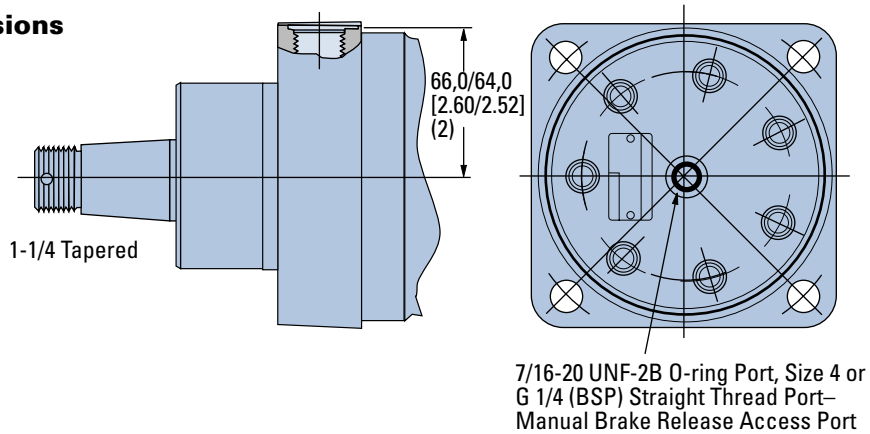

## PORTING AND MOUNTING DIMENSIONS

Displacement cm <sup>3</sup> /r [in <sup>3</sup> /r]	X mm [inch]	Y mm [inch]	Z mm [inch]
80 [4.9]	9,1 [0.36]	119,9 [4.72]	198,4 [7.81]
126 [7.7]	11,9 [0.47]	122,9 [4.84]	201,2 [7.92]
154 [9.4]	14,7 [0.58]	125,5 [4.94]	204,0 [8.03]
195 [11.9]	18,5 [0.73]	129,6 [5.10]	207,8 [8.18]
251 [15.3]	23,9 [0.94]	134,9 [5.31]	213,4 [8.40]
303 [18.5]	29,0 [1.14]	139,7 [5.50]	217,7 [8.59]
374 [22.8]	35,6 [1.40]	146,6 [5.77]	226,8 [8.85]

# W Series, W Series with Parking Brake (162-)

## Product Numbers

Use digit prefix —  
162 plus four digit number  
from charts for complete  
product number —  
Example 162-1153.

**Orders will not be accepted  
without three digit prefix.**

### Standard

SHAFT	DISPL. cm <sup>3</sup> /r [in <sup>3</sup> /r] / PRODUCT NUMBER						
	80 [4.9]	126 [7.7]	154 [9.4]	195 [11.9]	251 [15.3]	303 [18.5]	374 [22.8]
Standard	162-1016	-1017	-1018	-1019	-1020	-1021	-1022
w/Case Drain	162-1023	-1024	-1025	-1009	-1008	-1026	-1027

162-1009

### W Series with Parking Brake

SHAFT	DISPL. cm <sup>3</sup> /r [in <sup>3</sup> /r] / PRODUCT NUMBER						
	80 [4.9]	126 [7.7]	154 [9.4]	195 [11.9]	251 [15.3]	303 [18.5]	374 [22.8]
Standard	162-1143	-1044	-1045	-1046	-1034	-1048	-1049

162-1046

#### Note:

All above motors have 1 1/4  
inch tapered output shaft,  
7/8 inch O-ring ports.

For W Series Motors with  
a configuration not shown  
in the chart above: Use the  
model code number system  
to specify the product in  
detail. (see page B-5-8  
and use the model code  
supplement shown on page  
B-5-11 for spring-applied  
hydraulic-release parking  
brake).



# W Series with Parking Brake (162-)

## Model Code

The following 16-digit coding system has been developed to identify all of the configuration options for the W motor. Use this model code to specify a motor with the desired features. All 16-digits of the code must be present when ordering. You may want to photocopy the matrix below to ensure that each number is entered in the correct box.

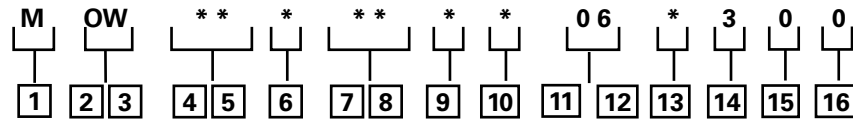

### 1 Product

**M** – Motor

### 2, 3 Series

**OW** – W Series with Parking Brake

### 4, 5 Displacement cm<sup>3</sup>/r [in<sup>3</sup>/r]

**05** – 30 [4.9]

**08** – 126 [7.7]

**09** – 154 [9.4]

**12** – 195 [11.9]

**15** – 251 [15.3]

**19** – 303 [18.5]

**23** – 374 [22.8]

### 6 Mounting Type

**B** – 4 Bolt (Wheel) 82,6 [3.25] Pilot Dia. and 13,59 [.535] Dia. Mounting Holes 147,6 [5.81] Dia., B.C., 127,0 [5.00] rear pilot

### 7, 8 Output Shaft

**02** – 1 1/4 inch Dia. Flat Root Side Fit, 14 Tooth, 12/24 DP 30° Involute Spline with 3/8-16 UNC-2B Thread in End, 33,0 [1.30] Min. Full Spline

**03** – 1 1/4 inch Dia. .125:1 Tapered Shaft Per SAE J501 with 1– 20 UNEF -2A Threaded Shaft End and Slotted Hex Nut, 7,938 [.3125] Square x 22,22 [.875] Straight Key

**04** – 32mm Dia. Straight Shaft with M8 x 1, 25-6H Thread in End, 9,982 [.3930] Wide x 7,995 [.3132] High x 45,00 [1.772] Long Key

**06** – 1 1/4 inch Dia. Straight Shaft with 3/8 – 16 UNC 2B Thread in End, 7,938 [.3125] Square x 34,92 [1.375] Straight Key

### 9 Ports

**A** – 7/8 -14 UNF - 2B SAE O-ring Port

**B** – G 1/2 (BSP) Straight Thread Port

### 10 Case Flow Options

**A** – 7/16 - 20 UNF - 2B SAE O-ring Port

**B** – G 1/4 (BSP) Straight Thread Port

**C** – Internal Check Valve

### 11, 12 Special Features (Hardware)

**00** – None

**01** – Viton Seals

**06** – Spring-applied hydraulic-release brake

### 13 Special Features (Assembly)

**0** – None

**1** – Reverse Rotation

### 14 Paint/Special Packaging

**0** – No Paint, Individual Box

**A** – Painted Low Gloss Black - Individual Box

### 15 Eaton Assigned Code when Applicable

**0** – Assigned Code

### 16 Eaton Assigned Design Code

**0** – Assigned Design Code

# Notes