



Char-Lynn

Disc Valve Hydraulic Motors

State of the art motors benefiting from 45 years of experience and inovating constantly to fit your demands.



Disc Valve Hydraulic Motors

Highlights

Product Description

In the late 1950's the original low speed, high torque hydraulic motor was developed from a pump Geroler element consisting of an internal gear ring and a mating gear or star. While attaching the internal gear ring to the housing as a non moving part, oil was ported to pressurize and turn the internal star in an orbit around a center point. This slow turning star coupled with a splined drive to the output shaft became the Char-Lynn® Orbit® motor. A few years after this original Char-Lynn Orbit motor was introduced another original motor concept went into production.

This motor had rolls incorporated into the internal gear ring, this element was identified by the name Geroler® and is a registered trade name of Eaton Hydraulics. From these early years the Geroler motor has seen many design changes to make these Geroler motors the best the industry has to offer. Examine the simplicity of these Geroler disc valve motors shown below. Also examine all the following pages for high value Char-Lynn disc valve motors from Eaton Hydraulics.

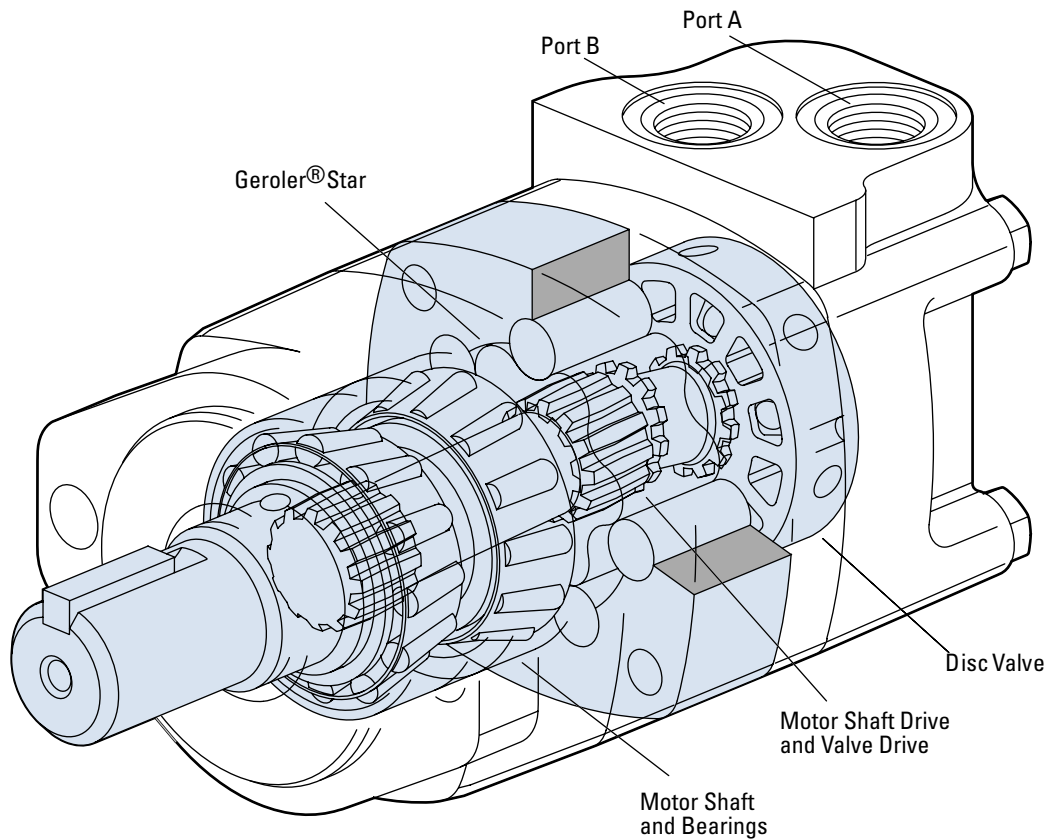

Features, Benefits, and Applications

Features

Char-Lynn Hydraulic motors provide design flexibility. All disc valve motors are available with various configurations consisting of:

- Displacement (Geroler size)
- Output Shaft
- No Shaft and Bearing Assembly (Bearingless Motor)
- Port Configuration
- Mounting Flange
- Other Special Features

Benefits

- Lowest pressure drop motor in the industry
- Widest range of options
- The most experienced manufacturer of LSHT motors

Applications

- Swing motor
- Brush Cutters & mowers
- Harvesting equipment
- Directional boring
- Turf equipment
- Skid Steer loaders
- Fairway mowers
- Harvesters
- Mowing
- Snow removal
- Sprayers
- Trencher
- Wood products
- Grinders and mixers
- Forestry equipment
- Irrigation reels

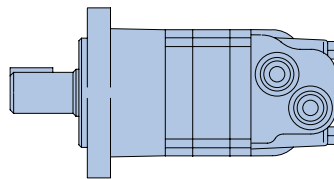

Standard Motor

The standard motor mounting flange is located as close to the output shaft as possible. This type of mounting supports the motor close to the shaft load. This mounting flange is also compatible with many standard gear boxes.

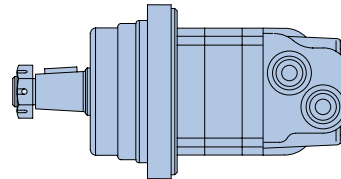

Wheel Motor

The wheel motor mounting flange is located near the center of the motor which permits part or all of the motor to be located inside the wheel or roller hub. In traction drive applications, loads can be positioned over the motor bearings for best bearing life. This wheel motor mounting flange provides design flexibility in many applications.

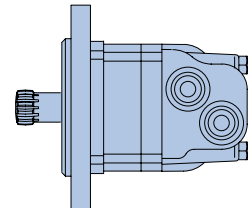

Bearingless Motor

The bearingless motor has the same drive components as the standard and wheel motors (with the exception that the motor is assembled without the output shaft, bearings and bearing housing). The bearingless motor is especially suited for applications such as gear boxes, winch drives, reel and roll drives. Bearingless motor applications must be designed with a bearing supported internal spline to mate with the bearingless motor drive. Product designs using these hydraulic motors provide considerable cost savings.

Table of Contents

Highlights	C-ii
Features, Benefits, and Applications	C-iii
Table of Contents	C-iv

2000 Series

Highlights	C-1-1
Specifications	C-1-2
Performance Data	C-1-3
Dimensions	C-1-8
Installation Information	C-1-14
Shaft Side Load Capacity	C-1-18
Case Pressure and Case Porting	C-1-19
Product Numbers	C-1-23
Model Code	C-1-24
<i>2000 Series Two-Speed</i>	
Description	C-1-25
Typical Hydraulic Circuit	C-1-26
Specifications	C-1-27
Dimensions	C-1-28
Product Numbers	C-1-30

4000 Compact Series

Highlights	C-2-1
Specifications	C-2-2
Performance Data	C-2-3
Dimensions	C-2-9
Installation Information	C-2-12
4000 Compact Series	C-2-13
Mounting Options	C-2-13
Dimensions	C-2-14
Mounting Options for use with Enhanced Bearings	C-2-14
Shaft Side Load Capacity	C-2-17
Case Pressure and Case Port	C-2-18
Model Code	C-2-22

4000 Series

Highlights	C-3-1
Specifications	C-3-2
Performance Data	C-3-3
Dimensions	C-3-8
Installation Information	C-3-11
Shaft Side Load Capacity	C-3-13
Case Pressure and Case Port	C-3-14
Product Numbers	C-3-16
Model Code	C-3-17

6000 Series

Highlights	C-4-1
Specifications	C-4-2
Performance Data	C-4-3
Dimensions	C-4-8
Installation Information	C-4-12
Shaft Side Load Capacity	C-4-14
Case Pressure and Case Port	C-4-15
Dimensions Ports	C-4-16
Product Numbers	C-4-17
Model Code	C-4-18

10,000 Series

Highlights	C-5-1
Specifications	C-5-2
Performance Data	C-5-3
Dimensions	C-5-5
Installation Information	C-5-8
Side Shaft Load Capacity	C-5-10
Product Numbers	C-5-12
Model Code	C-5-13
<i>10,000 Series Two-Speed</i>	
Description	C-5-14
Performance Data	C-5-14
Typical Hydraulic Circuit	C-5-15
Specifications	C-5-16
Dimensions	C-5-17
Product Numbers	C-5-19

2000 Series

Highlights

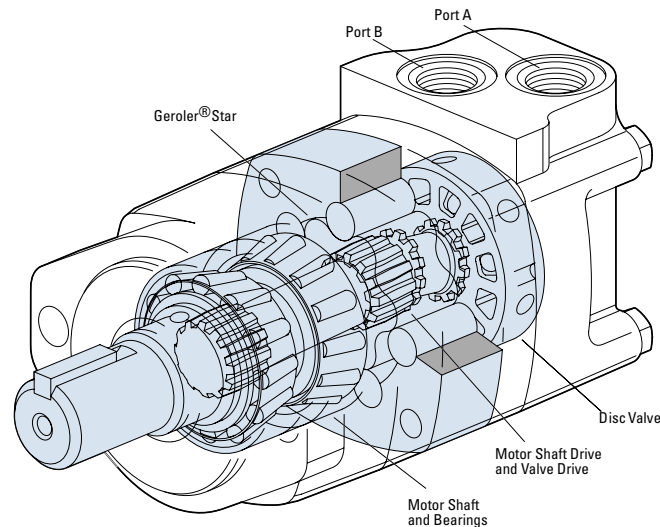

Description

The popular 2000 Series provides torque up to 7500 in-lb. This proven design is reliable and durable. Eaton has added options that make the motor more flexible to use in a wide variety of applications. The integral cross-over relief valve is the latest innovation in the 2000 series motors.

2000 Series

Geroler Element	10 Displacements
Flow l/min [GPM]	75 [20] Continuous**
	115 [30] Intermittent*
Speed RPM	908 Cont.**
	1042 Inter.*
Pressure bar [PSI]	200 [3000] Cont.**
	300 [4500] Inter.*
Torque Nm [lb-in]	845 [7470] Cont.**
	930 [8225] Inter.*

** Continuous— (Cont.) Continuous rating, motor may be run continuously at these ratings.

* Intermittent— (Inter.) Intermittent operation, 10% of every minute.

Features

- Three zone design for longer life and true bi-directionality.
- Bearings that meet the highest standards of the industry
- Options to optimize performance in every application
- Integrated cross-over relief valve option

Benefits

- Easy to design in a system
- Reliability and performance in tough application
- Compact design of the integrated cross-over relief valve option

Applications

- Skid Steer Attachments
- Swing Motor
- Brush Cutters & Mowers
- Harvesting Equipment
- Directional Boring any place pressure relief protection is optimal for system or motor performance and life
- Turf equipment



Auger



Boring



Plastic Injection



Oil and Gas Equipment

2000 Series

Specifications

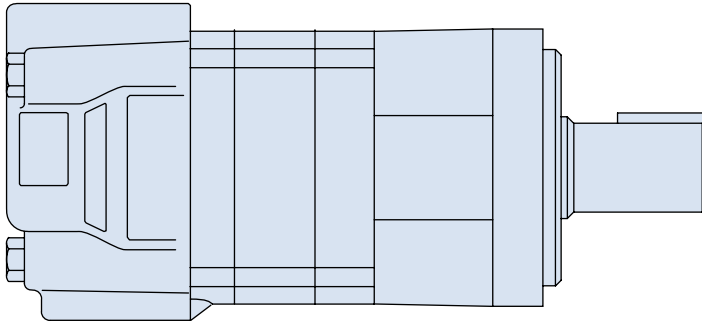

SPECIFICATION DATA — 2000 SERIES MOTORS

Displ. cm ³ /r [in ³ /r]		80 [4.9]	90 [5.5]	100 [6.2]	130 [8.0]	160 [9.6]	195 [11.9]	245 [14.9]	305 [18.7]	395 [24.0]	490 [29.8]
Max. Speed (RPM)	Continuous	908	836	742	576	477	385	308	246	191	153
	Intermittent	908	1042	924	720	713	577	462	365	287	230
@ Flow											
Flow l/min [GPM]	Continuous	75 [20]	75 [20]	75 [20]	75 [20]	75 [20]	75 [20]	75 [20]	75 [20]	75 [20]	75 [20]
	Intermittent	75 [20]	95 [25]	95 [25]	95 [25]	115 [30]	115 [30]	115 [30]	115 [30]	115 [30]	115 [30]
Torque* Nm [lb-in]	Continuous	235 [2065]	265 [2326]	295 [2630]	385 [3420]	455 [4040]	540 [4780]	660 [5850]	765 [6750]	775 [6840]	845 [7470]
	Intermittent	345 [3035]	390 [3458]	445 [3950]	560 [4970]	570 [5040]	665 [5890]	820 [7250]	885 [7820]	925 [8170]	930 [8225]
Pressure Δ bar [Δ PSI]	Continuous	205 [3000]	205 [3000]	205 [3000]	205 [3000]	205 [3000]	205 [3000]	205 [3000]	205 [3000]	155 [2250]	120 [1750]
	Intermittent	310 [4000]	310 [4000]	310 [4000]	310 [4000]	260 [3750]	260 [3750]	260 [3750]	260 [3750]	170 [2500]	140 [2000]
	Peak	310 [4000]	310 [4000]	310 [4000]	310 [4000]	310 [4000]	310 [4000]	310 [4000]	310 [4000]	205 [3000]	170 [2500]
Weight kg [lb]	Standard or Wheel Mount	9.3 [20.5]	9.3 [20.5]	9.5 [21.0]	9.8 [21.5]	10.0 [22.0]	10.4 [23.0]	10.9 [24.0]	11.3 [25.0]	11.8 [26.0]	12.2 [27.0]
	Bearingless	7.3 [16.0]	7.3 [16.0]	7.5 [16.5]	7.7 [17.0]	7.9 [17.5]	8.4 [18.5]	8.8 [18.5]	9.3 [20.5]	9.8 [21.5]	10.2 [22.5]

Maximum Case Pressure: See case pressure seal limitation graph.

*See shaft torque ratings for limitations.

Note:

To assure best motor life, run motor for approximately one hour at 30% of rated pressure before application to full load. Be sure motor is filled with fluid prior to any load applications.

Maximum Inlet Pressure:

310 bar [4500 PSI]
Do not exceed Δ pressure rating (see chart above).

Maximum Return Pressure:

310 bar [4500 PSI] with case drain line installed.
Do not exceed Δ pressure rating (see chart above).

Δ bar [Δ PSI] :

The true pressure difference between inlet port and outlet port

Continuous Rating:

Motor may be run continuously at these ratings

Intermittent Operation:

10% of every minute

Peak Operation:

1% of every minute

Recommended Fluids:

Premium quality, anti-wear type hydraulic oil with a viscosity of not less than 70 SUS at operating temperature.

Recommended Maximum System Operating Temp.:

82° C [180° F]

Recommended Filtration:





per ISO Cleanliness Code, 4406: 20/18/13

2000 Series

Performance Data

Motors run with high efficiency in all areas designated with a number for torque and speed. For best motor life select a motor to run with a torque and speed range shown in the light shaded area.

Performance data is typical at 120 SUS. Actual data may vary slightly from unit to unit in production.

	Continuous		Peak
	Intermittent		No Operation

90 cm³/r [5.5 in³/r]
Δ Pressure Bar [PSI]

	[250]	[500]	[1000]	[1500]	[2000]	[2500]	[3000]	[3500]	[4000]	[4500]
	15	35	70	105	140	170	205	240	275	310
[.25]	[124]	[233]	[471]							
.95	14	26	53							
	5	2	1							
[.5]	[133]	[273]	[555]	[832]						
1.9	15	31	63	94						
	15	13	6	2						
[1]	[151]	[358]	[744]	[1091]	[1424]	[1697]	[1952]	[2189]	[2368]	
3.8	17	40	84	123	161	192	221	247	268	
	39	39	35	32	28	21	13	12	2	
[2]	[151]	[358]	[744]	[1099]	[1439]	[1737]	[2015]	[2293]	[2570]	[2855]
7.5	17	40	84	124	163	196	228	259	290	323
	82	80	76	72	68	61	50	38	29	20
[4]	[151]	[350]	[899]	[1113]	[1473]	[1800]	[2132]	[2454]	[2775]	[3100]
15	17	40	102	126	166	203	241	277	314	350
	167	163	158	152	148	139	126	115	102	90
[6]	[142]	[348]	[736]	[613]	[1492]	[1851]	[2208]	[2552]	[2898]	[3249]
23	16	39	83	69	169	209	249	288	327	367
	250	245	240	233	227	218	203	191	176	161
[8]	[133]	[338]	[729]	[1128]	[1509]	[1890]	[2269]	[2635]	[3000]	[3367]
30	15	38	82	127	170	214	256	298	339	380
	35	328	329	314	306	295	281	266	249	231
[10]	[124]	[331]	[724]	[1130]	[1521]	[1912]	[2309]	[2670]	[3036]	[3398]
38	14	37	82	128	172	216	261	302	343	384
	418	410	404	395	385	373	361	342	322	302
[12]	[106]	[315]	[714]	[1127]	[1525]	[1924]	[2326]	[2704]	[3082]	[3458]
45	12	36	81	127	172	217	263	306	348	391
	502	493	485	477	464	451	441	417	394	372
[14]	[98]	[298]	[706]	[1115]	[1525]	[1924]	[2326]	[2707]	[3080]	[3450]
53	11	34	80	126	172	217	263	306	348	390
	585	575	567	559	543	529	521	493	467	431
[16]	[80]	[285]	[688]	[1107]	[1510]	[1907]	[2311]	[2697]	[3070]	[3432]
61	9	32	78	125	171	215	261	305	347	388
	670	658	650	641	622	607	610	568	541	513
[18]	[62]	[262]	[673]	[1087]	[1490]	[1892]	[2281]	[2662]	[3030]	[3381]
68	7	30	76	123	168	214	258	301	342	382
	753	740	732	719	701	685	680	643	613	583
[20]	[53]	[242]	[644]	[1045]	[1447]	[1850]	[2246]	[2617]	[2988]	[3301]
76	6	27	73	118	163	209	254	296	338	373
	836	822	814	796	780	765	748	719	686	653
[22]	[35]	[231]	[639]	[1047]	[1437]	[1836]	[2218]	[2599]	[2981]	
83	4	26	72	118	162	207	251	294	337	
	920	916	907	895	876	854	749	803	774	
[24]	[18]	[204]	[612]	[1011]	[1366]	[1792]	[2182]	[2573]	[2963]	
91	2	23	69	114	154	202	247	291	335	
	1003	1000	991	978	960	940	918	882	850	
[25]		[195]	[594]	[994]	[1384]	[1765]	[2173]	[2564]		
95		22	67	112	156	199	246	290		
		1042	1033	1020	1003	984	954	921		

80 cm³/r [4.9 in³/r]
Δ Pressure Bar [PSI]

	[500]	[1000]	[1500]	[2000]	[2500]	[3000]	[3500]	[4000]	[4500]
	35	70	105	140	170	205	240	275	310
[.25]	[210]	[420]							
.95	25	45							
	3	1							
[.5]	[250]	[500]	[740]						
1.9	30	50	85						
	17	8	3						
[1]	[330]	[670]	[990]	[1300]	[1550]	[1800]	[1950]	[2110]	
3.8	35	75	110	145	175	205	220	240	
	44	40	37	34	28	22	14	2	
[2]	[330]	[670]	[995]	[1310]	[1580]	[1840]	[2100]	[2365]	[2630]
7.5	35	75	110	150	180	210	235	265	295
	90	85	81	78	72	65	57	49	42
[4]	[325]	[670]	[1005]	[1330]	[1620]	[1920]	[2200]	[2480]	[2765]
15	35	75	115	150	185	215	250	280	310
	182	176	170	166	159	152	140	128	117
[6]	[320]	[665]	[1010]	[1340]	[1655]	[1975]	[2270]	[2570]	[2880]
23	35	75	115	150	185	225	255	290	325
	273	267	259	254	246	238	223	207	192
[8]	[310]	[660]	[1015]	[1345]	[1685]	[2020]	[2330]	[2640]	[2960]
30	35	75	115	150	190	230	265	300	335
	365	375	349	341	333	325	306	286	266
[10]	[300]	[650]	[1010]	[1350]	[1700]	[2050]	[2370]	[2690]	[3010]
38	35	75	115	155	190	230	270	305	340
	456	448	439	429	420	411	388	364	341
[12]	[285]	[640]	[1005]	[1350]	[1705]	[2065]	[2390]	[2715]	[3035]
45	30	70	115	155	195	235	270	305	345
	547	537	530	516	507	497	470	442	415
[14]	[270]	[625]	[990]	[1340]	[1705]	[2065]	[2395]	[2720]	[3030]
53	30	70	110	150	195	235	270	305	340
	638	629	622	603	593	584	553	521	490
[16]	[255]	[610]	[975]	[1330]	[1690]	[2055]	[2385]	[2700]	[2995]
61	30	70	110	150	190	230	270	305	340
	729	720	714	689	679	670	635	599	564
[18]	[230]	[590]	[955]	[1310]	[1680]	[2025]	[2355]	[2660]	[2935]
68	25	65	110	150	190	230	265	300	330
	818	810	795	775	765	756	717	677	638
[20]	[210]	[570]	[930]	[1290]	[1645]	[1985]	[2305]	[2600]	[2845]
76	25	65	105	145	185	225	260	295	320
	908	901	880	861	851	842	799	755	712





[570] } Torque [lb-in]
65 } Nm
901 } Speed RPM

2000 Series

Performance Data

Motors run with high efficiency in all areas designated with a number for torque and speed. For best motor life select a motor to run with a torque and speed range shown in the light shaded area.

Performance data is typical at 120 SUS. Actual data may vary slightly from unit to unit in production.

	Continuous		Peak
	Intermittent		No Operation

100 cm³/r [6.2 in³/r]
 Δ Pressure Bar [PSI]

[250] 15	[500] 35	[1000] 70	[1500] 105	[2000] 140	[2500] 170	[3000] 205	[3500] 240	[4000] 275	[4500] 310
-------------	-------------	--------------	---------------	---------------	---------------	---------------	---------------	---------------	---------------

[.25] .95	[140] 15 4	[260] 30 2							
[.5] 1.9	[150] 15 13	[300] 35 9	[620] 70 5	[940] 105 2					
[1] 3.8	[170] 20 35	[390] 45 34	[830] 95 31	[1210] 135 28	[1570] 175 23	[1870] 210 15	[2130] 240 6		
[2] 7.5	[170] 20 73	[390] 45 71	[830] 95 68	[1220] 140 63	[1590] 180 59	[1920] 215 51	[2220] 250 38	[2520] 285 24	[2810] 315 14
[4] 15	[170] 20 148	[380] 45 145	[820] 90 141	[1240] 140 136	[1640] 185 131	[2010] 225 121	[2380] 270 104	[2750] 310 94	[3120] 355 80
[6] 23	[160] 20 222	[380] 45 219	[820] 90 215	[1260] 140 209	[1670] 190 202	[2080] 235 192	[2480] 280 172	[2880] 325 163	[3280] 370 149
[8] 30	[150] 15 297	[370] 40 294	[810] 90 288	[1260] 140 281	[1700] 190 273	[2130] 240 261	[2560] 290 243	[2990] 340 231	[3420] 385 216
[10] 38	[140] 15 371	[368] 40 367	[810] 90 362	[1270] 145 354	[1720] 195 344	[2160] 245 330	[2610] 295 316	[3020] 340 300	[3440] 390 283
[12] 45	[120] 15 445	[350] 40 442	[800] 90 436	[1270] 145 427	[1730] 195 415	[2180] 245 399	[2630] 295 389	[3070] 345 369	[3510] 395 350
[14] 53	[110] 10 519	[330] 35 516	[800] 90 509	[1260] 140 500	[1740] 195 486	[2180] 245 469	[2630] 295 463	[3070] 345 437	[3500] 395 417
[16] 61	[90] 10 594	[320] 35 591	[780] 90 583	[1260] 140 573	[1720] 195 558	[2160] 245 540	[2610] 295 537	[3060] 345 506	[3500] 395 485
[18] 68	[70] 10 668	[300] 35 665	[770] 85 657	[1240] 140 646	[1700] 190 630	[2140] 240 611	[2580] 290 609	[3020] 340 574	[3460] 390 552
[20] 76	[60] 5 742	[280] 30 739	[730] 80 731	[1180] 135 715	[1630] 185 703	[2090] 235 684	[2550] 290 662	[2980] 335 643	[3440] 390 619
[22] 83	[40] 5 816	[260] 30 813	[720] 80 805	[1180] 135 794	[1620] 185 777	[2070] 235 758	[2500] 280 749	[2930] 330 712	[3360] 380 687
[24] 91	[20] 1,0 890	[230] 230 887	[690] 80 879	[1140] 130 868	[1540] 175 852	[2020] 230 834	[2460] 280 814	[2900] 330 782	[3340] 375 754
[25] 95		[220] 25 924	[670] 75 916	[1120] 125 905	[1560] 175 890	[1990] 225 873	[2450] 275 846	[2890] 325 817	

130 cm³/r [8.0 in³/r]
 Δ Pressure Bar [PSI]

[250] 15	[500] 35	[1000] 70	[1500] 105	[2000] 140	[2500] 170	[3000] 205	[3500] 240	[4000] 275	[4500] 310
-------------	-------------	--------------	---------------	---------------	---------------	---------------	---------------	---------------	---------------

[.25] .95	[170] 20 3								
[.5] 1.9	[190] 20 12	[410] 45 8	[870] 100 2						
[1] 3.8	[230] 25 28	[510] 60 27	[1070] 120 23	[1580] 180 19	[2050] 230 16	[2520] 285 13	[2920] 330 9	[3310] 375 3	
[2] 7.5	[230] 25 56	[510] 60 56	[1080] 120 53	[1600] 180 47	[2090] 235 42	[2580] 290 39	[2930] 330 36	[3320] 375 28	[3640] 410 21
[4] 15	[220] 25 114	[500] 55 113	[1080] 120 111	[1620] 185 104	[2150] 245 97	[2660] 300 95	[3100] 350 92	[3540] 400 85	[3980] 450 77
[6] 23	[220] 25 172	[490] 55 171	[1080] 120 169	[1640] 185 161	[2190] 245 153	[2740] 310 149	[3260] 370 146	[3770] 425 132	[4280] 485 118
[8] 30	[200] 25 230	[480] 55 224	[1080] 120 222	[1650] 185 219	[2220] 250 210	[2780] 315 204	[3310] 375 201	[3840] 435 192	[4360] 495 184
[10] 38	[180] 20 287	[470] 55 286	[1070] 120 282	[1650] 185 276	[2230] 250 269	[2800] 315 261	[3420] 385 255	[3940] 445 243	[4450] 505 231
[12] 45	[160] 20 345	[460] 50 344	[1060] 120 338	[1640] 185 333	[2230] 250 327	[2800] 315 317	[3350] 380 307	[3910] 440 295	[4440] 500 284
[14] 53	[150] 15 403	[440] 50 402	[1030] 115 395	[1620] 185 391	[2220] 250 385	[3000] 340 373	[3350] 380 360	[3910] 440 348	[4440] 500 336
[16] 61	[130] 15 461	[420] 45 460	[1010] 115 452	[1600] 180 447	[2200] 250 443	[2780] 315 430	[3330] 375 411	[3890] 440 397	[4440] 500 384
[18] 68	[110] 10 518	[400] 45 517	[990] 110 509	[1580] 180 504	[2160] 245 500	[2750] 310 484	[3300] 375 471	[3860] 435 456	[4410] 500 440
[20] 76	[90] 10 576	[380] 45 575	[960] 110 568	[1550] 175 560	[2130] 240 551	[2710] 305 539	[3280] 370 524	[3840] 435 508	
[22] 83	[60] 5 634	[350] 40 633	[940] 105 624	[1520] 170 619	[2100] 235 604	[2680] 305 597	[3250] 365 579	[3820] 430 560	
[24] 91	[40] 5 692	[325] 35 691	[920] 105 682	[1490] 170 676	[2070] 235 665	[2650] 300 651	[3220] 365 633	[3780] 425 616	
[25] 95	[20] 1,0 720	[310] 35 719	[900] 100 712	[1480] 165 705	[2050] 230 692	[2630] 295 679	[3200] 360 682	[3700] 420 656	

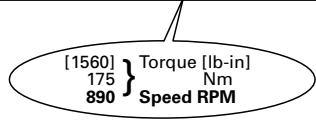





2000 Series

Performance Data

Motors run with high efficiency in all areas designated with a number for torque and speed. For best motor life select a motor to run with a torque and speed range shown in the light shaded area.

Performance data is typical at 120 SUS. Actual data may vary slightly from unit to unit in production.

	Continuous		Peak
	Intermittent		No Operation

160 cm³/r [9.6 in³/r]
Δ Pressure Bar [PSI]

	[250] 15	[500] 35	[1000] 70	[1500] 105	[2000] 140	[2500] 170	[3000] 205	[3500] 240	[3750] 260
[.25] .95	[200] 25 3								
[.5] 1.9	[240] 25 9	[490] 55 7	[990] 110 5	[1570] 175 3	[2140] 240 1				
[1] 3.8	[280] 30 23	[590] 65 21	[1170] 130 19	[1730] 195 17	[2290] 260 13	[2830] 320 8	[3330] 375 3	[3820] 430 2	[4070] 460 1
[2] 7.5	[300] 35 46	[610] 70 45	[1210] 135 42	[1790] 200 39	[2350] 265 35	[2920] 330 34	[3480] 395 33	[4050] 460 28	[4330] 490 22
[4] 15	[320] 35 93	[630] 70 92	[1260] 140 89	[1890] 215 85	[2530] 285 79	[3170] 360 77	[3820] 430 75	[4460] 505 59	[4780] 540 43
[6] 23	[320] 35 142	[650] 75 140	[1300] 145 137	[1960] 220 131	[2620] 295 124	[3280] 370 118	[3940] 445 113	[4600] 520 104	[4930] 560 96
[8] 30	[310] 35 190	[650] 75 187	[1330] 150 184	[2010] 225 178	[2670] 300 170	[3330] 375 166	[4000] 450 164	[4660] 525 153	[4990] 565 142
[10] 38	[290] 35 237	[640] 70 235	[1340] 150 231	[2030] 230 226	[2850] 320 217	[3410] 385 212	[4030] 455 205	[4700] 530 193	[5030] 570 187
[12] 45	[270] 30 286	[620] 70 283	[1320] 150 279	[2030] 230 274	[2700] 305 265	[3370] 380 254	[4040] 455 246	[4710] 530 235	[5040] 570 224
[14] 53	[240] 25 334	[590] 65 331	[1200] 145 326	[2020] 230 322	[2690] 305 312	[3360] 380 305	[4030] 455 297	[4700] 530 286	
[16] 61	[220] 25 382	[570] 65 378	[1270] 145 374	[1980] 225 369	[2660] 300 360	[3330] 375 349	[4010] 455 339	[4680] 530 326	
[18] 68	[190] 20 429	[540] 60 426	[1240] 140 422	[1960] 220 416	[2640] 300 407	[3320] 375 394	[3990] 450 387		
[20] 76	[170] 20 477	[510] 60 470	[1210] 135 469	[1920] 215 462	[2630] 300 451	[3310] 375 440	[3940] 445 430		
[22] 83	[150] 15 525	[480] 55 522	[1170] 130 517	[1880] 210 510	[2600] 295 501	[3290] 370 484	[3920] 445 473		
[24] 91	[120] 15 572	[450] 50 569	[1150] 130 564	[1860] 210 556	[2570] 290 546	[3260] 370 531	[3900] 440 522		
[25] 95	[90] 10 596	[440] 50 593	[1140] 130 587	[1840] 210 580	[2560] 290 566	[3230] 365 553	[3880] 440 544		
[30] 114		[330] 35 713	[1040] 120 706	[1750] 200 696	[2470] 280 682	[3140] 355 672	[3800] 430 658		

[330]
35 } Torque [lb-in]
713 } Speed RPM

195 cm³/r [11.9 in³/r]
Δ Pressure Bar [PSI]





	[250] 15	[500] 35	[750] 50	[1000] 70	[1250] 85	[1500] 105	[1750] 120	[2000] 140	[2250] 155	[2500] 170	[2750] 190	[3000] 205	[3250] 225	[3500] 240	[3750] 260
[.25] .95	[240] 25 4	[590] 65 2													
[.5] 1.9	[290] 35 8	[640] 70 6	[990] 110 5	[1340] 150 2											
[1] 3.8	[380] 45 17	[730] 80 16	[1100] 125 15	[1430] 160 14	[1790] 200 13	[2120] 200 11	[2450] 275 9	[2720] 305 7	[2990] 340 5	[3260] 370 4	[3540] 400 3	[3810] 430 2	[4080] 460 2	[4350] 490 1	[4620] 520 1
[2] 7.5	[390] 45 37	[755] 85 35	[1135] 130 34	[1470] 165 33	[1860] 210 31	[2195] 250 28	[2535] 285 26	[2880] 325 24	[3120] 355 21	[3360] 400 21	[3600] 445 20	[3840] 490 19	[4080] 540 17	[4320] 595 14	[4560] 640 14
[4] 15	[405] 45 76	[795] 90 74	[1185] 135 73	[1540] 175 72	[1970] 225 70	[2310] 260 70	[2675] 300 66	[3040] 345 64	[3420] 385 62	[3790] 430 61	[4160] 470 59	[4520] 510 57	[4890] 550 55	[5260] 595 51	[5630] 635 45
[6] 23	[405] 45 115	[815] 90 113	[1220] 140 111	[1590] 180 110	[2035] 230 109	[2395] 270 108	[2780] 315 104	[3170] 360 102	[3560] 400 100	[3940] 445 99	[4320] 490 96	[4700] 530 94	[5070] 570 91	[5450] 615 87	[5830] 660 81
[8] 30	[400] 45 154	[820] 90 151	[1230] 140 149	[1625] 185 148	[2065] 235 147	[2450] 275 146	[2850] 320 143	[3260] 370 140	[3670] 415 137	[4040] 455 135	[4410] 500 132	[4780] 540 130	[5150] 580 127	[5520] 625 123	[5890] 665 117
[10] 38	[380] 45 193	[810] 95 190	[1230] 140 188	[1645] 185 187	[2095] 235 186	[2480] 280 184	[2895] 325 181	[3310] 375 177	[3730] 420 175	[4100] 465 173	[4470] 505 170	[4840] 545 168	[5210] 590 164	[5590] 630 160	
[12] 45	[355] 40 231	[790] 90 229	[1215] 135 227	[1650] 185 226	[2100] 235 224	[2485] 280 221	[2915] 330 219	[3340] 375 218	[3760] 425 215	[4120] 465 211	[4480] 505 208	[4850] 550 204			
[14] 53	[320] 35 269	[765] 85 267	[1190] 135 267	[1645] 185 264	[2090] 235 262	[2475] 280 260	[2915] 330 257	[3350] 380 254	[3770] 425 250	[4130] 465 248	[4480] 505 245	[4860] 550 241			
[16] 61	[290] 30 308	[730] 80 306	[1160] 130 305	[1625] 185 303	[2070] 235 299	[2455] 275 296	[2900] 330 294	[3340] 375 290	[3760] 425 286	[4130] 465 283	[4490] 505 279	[4860] 550 276			
[18] 68	[290] 30 346	[690] 80 345	[1120] 125 345	[1590] 180 342	[2035] 230 337	[2420] 270 334	[2870] 325 327	[3310] 375 321	[3730] 420 315	[4100] 465 308	[4480] 505 308				
[20] 76	[210] 25 385	[650] 75 384	[1080] 120 383	[1550] 175 380	[1995] 225 375	[2380] 270 372	[2830] 320 367	[3270] 370 363	[3690] 415 359	[4070] 460 355	[4450] 500 355				
[22] 83	[170] 20 424	[610] 70 423	[1040] 120 422	[1500] 170 418	[1955] 220 414	[2340] 265 410	[2785] 315 408	[3220] 365 404	[3640] 410 399	[4050] 460 395					
[24] 91	[135] 15 462	[570] 65 461	[1000] 115 460	[1440] 165 457	[1910] 215 453	[2300] 260 449	[2740] 310 446	[3170] 360 441	[3590] 405 436	[3980] 450 432					
[25] 95	[120] 15 484	[550] 60 482	[980] 110 479	[1410] 160 476	[1890] 215 473	[2280] 260 469	[2720] 305 464	[3150] 355 459	[3570] 405 454	[3960] 445 449					
[30] 114		[420] 45 577	[860] 95 575	[1290] 145 571	[1700] 190 567	[2120] 240 562	[2530] 285 556	[2940] 330 550	[3400] 385 542						

2000 Series

Performance Data

Motors run with high efficiency in all areas designated with a number for torque and speed. For best motor life select a motor to run with a torque and speed range shown in the light shaded area.

Performance data is typical at 120 SUS. Actual data may vary slightly from unit to unit in production.

	Continuous		Peak
	Intermittent		No Operation

245 cm³/r [14.9 in³/r]
Δ Pressure Bar [PSI]

	[250] 15	[500] 35	[750] 50	[1000] 70	[1250] 85	[1500] 105	[1750] 120	[2000] 140	[2250] 155	[2500] 170	[2750] 190	[3000] 205	[3250] 225	[3500] 240	[3750] 260
[.5] 1.9	[410] 45	[850] 95													
[1] 3.8	[450] 50	[930] 105	[1420] 160	[1850] 210	[2320] 260	[2780] 315	[3250] 365	[3650] 410	[4100] 465	[4540] 515	[4980] 560	[5430] 615	[5870] 665	[6310] 715	
[2] 7.5	[460] 50	[960] 110	[1460] 165	[1900] 215	[2400] 270	[2860] 325	[3340] 375	[3780] 425	[4320] 490	[4770] 540	[5210] 590	[5660] 640	[6110] 690	[6570] 740	[6950] 785
[4] 15	[470] 55	[1000] 115	[1540] 175	[1980] 225	[2510] 285	[3010] 340	[3480] 395	[3980] 450	[4450] 505	[4910] 555	[5380] 610	[5850] 660	[6320] 715	[6780] 765	[7250] 820
[6] 23	[460] 50	[1020] 115	[1550] 175	[2040] 230	[2580] 290	[3110] 350	[3590] 405	[4120] 465	[4580] 515	[5050] 570	[5520] 625	[5980] 675	[6440] 730	[6910] 780	
[8] 30	[460] 50	[1010] 115	[1560] 175	[2080] 235	[2630] 295	[3170] 360	[3670] 415	[4210] 475	[4680] 530	[5160] 585	[5630] 635	[6110] 690	[6590] 745		
[10] 38	[440] 50	[1000] 115	[1550] 175	[2110] 240	[2650] 300	[3200] 360	[3730] 420	[4250] 480	[4730] 535	[5210] 580	[5720] 645	[6230] 705			
[12] 45	[410] 45	[960] 110	[1530] 175	[2100] 235	[2640] 300	[3190] 360	[3760] 425	[4260] 480	[4740] 535	[5220] 600	[5730] 645				
[14] 53	[380] 40	[910] 105	[1500] 170	[2080] 235	[2600] 295	[3160] 355	[3760] 425	[4230] 480	[4710] 530	[5190] 585					
[16] 61	[340] 40	[860] 95	[1460] 165	[2040] 230	[2570] 290	[3120] 355	[3740] 425	[4180] 475	[4660] 525	[5140] 580					
[18] 68	[290] 30	[810] 90	[1420] 160	[2000] 225	[2520] 285	[3060] 345	[3700] 420	[4130] 465	[4610] 520	[5090] 575					
[20] 76	[250] 30	[800] 90	[1350] 155	[1910] 215	[2460] 280	[3010] 340	[3630] 410	[4110] 465	[4610] 520						
[22] 83	[200] 25	[710] 80	[1300] 145	[1870] 210	[2390] 270	[2940] 330	[3560] 400	[4010] 455	[4510] 510						
[24] 91	[150] 15	[670] 75	[1240] 140	[1790] 200	[2330] 265	[2880] 325	[3460] 390	[3960] 445	[4460] 505						
[25] 95	[120] 15	[660] 75	[1210] 135	[1750] 200	[2300] 260	[2860] 325	[3410] 385	[3950] 445	[4470] 505						
[30] 114		[520] 60	[1080] 120	[1620] 185	[2180] 245	[2720] 305	[3260] 370	[3790] 430							

305 cm³/r [18.7 in³/r]
Δ Pressure Bar [PSI]

	[250] 15	[500] 35	[750] 50	[1000] 70	[1250] 85	[1500] 105	[1750] 120	[2000] 140	[2250] 155	[2500] 170	[2750] 190	[3000] 205	[3250] 225	[3500] 240
[.5] 1.9	[500] 55	[1050] 120												
[1] 3.8	[610] 70	[1180] 135	[1750] 200	[2330] 260	[2870] 325	[3440] 390	[3930] 445	[4410] 500	[4900] 555	[5380] 610				
[2] 7.5	[620] 70	[1210] 135	[1800] 205	[2400] 270	[2970] 335	[3510] 395	[4050] 460	[4600] 520	[5140] 580	[5680] 640	[6220] 705	[6750] 765	[7290] 825	[7820] 885
[4] 15	[680] 75	[1250] 140	[1880] 210	[2500] 280	[3120] 355	[3690] 415	[4260] 480	[4840] 545	[5410] 610	[5980] 675	[6550] 740	[7120] 805	[7690] 870	
[6] 23	[620] 70	[1270] 145	[1920] 215	[2560] 290	[3230] 365	[3810] 430	[4390] 495	[4970] 560	[5560] 630	[6130] 695	[6710] 760	[7290] 825		
[8] 30	[600] 70	[1270] 145	[1940] 220	[2600] 295	[3290] 370	[3880] 440	[4470] 505	[5070] 575	[5660] 640	[6250] 705	[6840] 775			
[10] 38	[570] 65	[1250] 140	[1940] 220	[2610] 295	[3310] 375	[3920] 440	[4530] 510	[5150] 580	[5760] 650	[6370] 720				
[12] 45	[530] 60	[1220] 140	[1920] 215	[2600] 295	[3300] 375	[3920] 440	[4530] 510	[5150] 580	[5760] 650	[6370] 720				
[14] 53	[480] 55	[1180] 135	[1870] 210	[2560] 290	[3260] 370	[3900] 440	[4510] 510	[5120] 580	[5730] 645					
[16] 61	[430] 50	[1120] 125	[1820] 205	[2500] 280	[3210] 365	[3870] 440	[4480] 505	[5080] 575	[5690] 645					
[18] 68	[370] 40	[1060] 120	[1760] 200	[2440] 275	[3140] 355	[3800] 440	[4420] 500	[5050] 570						
[20] 76	[320] 35	[980] 110	[1680] 190	[2360] 265	[3050] 345	[3710] 420	[4370] 495	[5020] 565						
[22] 83	[240] 25	[920] 105	[1620] 185	[2300] 260	[2990] 340	[3560] 400	[4190] 475	[4820] 545						
[24] 91	[180] 20	[870] 100	[1550] 175	[2240] 255	[2920] 330	[3420] 385	[4020] 455	[4630] 525						
[25] 95	[150] 15	[840] 95	[1520] 170	[2200] 250	[2890] 325	[3340] 375	[3930] 445	[4520] 510						
[30] 114		[680] 75	[1360] 155	[2040] 230	[2720] 305	[3140] 355	[3810] 430							





[3260] } Torque [lb-in]
[370] } Nm
[450] Speed RPM

2000 Series

Performance Data

Motors run with high efficiency in all areas designated with a number for torque and speed. For best motor life select a motor to run with a torque and speed range shown in the light shaded area.

Performance data is typical at 120 SUS. Actual data may vary slightly from unit to unit in production.

	Continuous		Peak
	Intermittent		No Operation

490 cm³/r [29.8 in³/r] Δ Pressure Bar [PSI]

	[250] 15	[500] 35	[750] 50	[1000] 70	[1250] 85	[1500] 105	[1750] 120	[2000] 140
[.5]	[670] 75 2	[1600] 180 1						
1.9								
[1]	[920] 105 7	[2000] 225 6	[2990] 340 5	[3900] 440 4	[4880] 550 2			
3.8								
[2]	[950] 105 14	[2060] 235 13	[3110] 350 12	[4080] 460 10	[5110] 575 9	[6320] 715 7		
7.5								
[4]	[980] 110 30	[2130] 240 29	[3230] 365 28	[4270] 480 27	[5350] 605 26	[6370] 720 24	[7380] 835 22	[7980] 900 20
15								
[6]	[980] 110 45	[2120] 240 44	[3230] 365 43	[4300] 485 42	[5370] 605 41	[6420] 725 39	[7470] 845 37	[8225] 930 35
23								
[8]	[980] 110 61	[2110] 240 60	[3220] 365 59	[4330] 490 58	[5400] 610 57	[6470] 730 55	[7550] 855 52	
30								
[10]	[920] 105 76	[2050] 230 75	[3170] 360 74	[4300] 485 73	[5390] 610 72	[6460] 730 70	[7550] 855 68	
38								
[12]	[860] 95 91	[1990] 225 90	[3120] 355 90	[4260] 480 89	[5370] 605 87	[6460] 730 85	[7560] 855 84	
45								
[14]	[790] 90 106	[1930] 220 105	[3055] 345 105	[4185] 475 104	[5300] 600 102	[6400] 725 100		
53								
[16]	[720] 80 122	[1870] 210 121	[2990] 340 120	[4110] 465 119	[5230] 590 118	[6340] 715 116		
61								
[18]	[630] 70 137	[1770] 200 136	[2890] 325 135	[4020] 455 134	[5140] 580 133	[6260] 705 131		
68								
[20]	[550] 60 153	[1670] 190 152	[2800] 315 151	[3940] 445 150	[5060] 570 149	[6180] 700 146		
76								
[22]	[450] 50 168	[1570] 175 168	[2700] 305 167	[3830] 435 165	[4960] 560 164	[6070] 685 161		
83								
[24]	[360] 40 184	[1480] 165 184	[2600] 295 183	[3730] 420 181	[4860] 550 179	[5970] 675 177		
91								
[26]	[270] 30 199	[1390] 155 195	[2510] 285 194	[3640] 410 192	[4770] 540 190			
98								
[28]		[1260] 140 212	[2370] 270 211	[3520] 400 209	[4630] 525 207			
106								
[30]		[1130] 125 230	[2240] 255 229	[3400] 385 277	[4500] 510 224			
114								

395 cm³/r [24.0 in³/r] Δ Pressure Bar [PSI]

	[250] 15	[500] 35	[750] 50	[1000] 70	[1250] 85	[1500] 105	[1750] 120	[2000] 140	[2250] 155	[2500] 170	[2750] 190
[.5]	[560] 65 4	[1310] 150 3									
1.9											
[1]	[770] 85 9	[1540] 175 9	[2290] 260 9	[3080] 350 8	[3780] 430 8	[4480] 505 7	[5170] 585 7	[5880] 665 6	[6580] 745 5	[7270] 820 4	[7980] 900 3
3.8											
[2]	[790] 90 18	[1580] 180 18	[2360] 265 18	[3180] 360 17	[3930] 445 17	[4680] 530 16	[5430] 615 15	[6180] 700 14	[6840] 775 13	[7500] 845 11	[8170] 925 10
7.5											
[4]	[810] 90 37	[1660] 190 37	[2480] 280 37	[3320] 375 36	[4130] 465 36	[4940] 560 35	[5740] 650 34	[6550] 740 33	[7230] 815 31	[7880] 890 28	
15											
[6]	[820] 90 57	[1700] 190 56	[2550] 290 56	[3420] 385 55	[4250] 480 54	[5080] 575 52	[5920] 670 50	[6750] 765 49	[7420] 840 47	[8000] 905 45	
23											
[8]	[820] 90 76	[1700] 190 75	[2580] 290 75	[3460] 390 74	[4300] 485 73	[5130] 580 71	[5960] 675 69	[6800] 770 68			
30											
[10]	[800] 90 95	[1700] 190 94	[2590] 295 94	[3480] 395 93	[4320] 490 92	[5160] 585 90	[6000] 680 88	[6840] 775 86			
38											
[12]	[770] 85 114	[1680] 190 113	[2570] 290 113	[3470] 390 112	[4310] 485 111	[5150] 580 109	[5990] 675 106	[6830] 770 103			
45											
[14]	[740] 85 133	[1640] 185 132	[2530] 285 132	[3430] 390 131	[4280] 485 129	[5120] 575 127	[5960] 675 124				
53											
[16]	[690] 80 153	[1590] 180 152	[2480] 280 152	[3370] 380 150	[4220] 475 149	[5060] 575 146	[5910] 670 144				
61											
[18]	[640] 70 172	[1530] 170 171	[2420] 275 171	[3310] 375 170	[4160] 470 169	[5010] 565 167	[5870] 665 164				
68											
[20]	[580] 65 191	[1470] 165 190	[2370] 270 190	[3260] 370 189	[4110] 465 188	[4960] 565 186	[5820] 660 184				
76											
[22]	[510] 60 210	[1390] 155 209	[2290] 260 209	[3170] 360 208	[4030] 455 207	[4880] 550 206					
83											
[24]	[440] 50 230	[1330] 150 229	[2220] 250 228	[3100] 350 227	[3950] 445 225	[4800] 540 224					
91											
[26]	[350] 40 249	[1240] 140 248	[2130] 240 247	[3020] 340 246	[3880] 440 244	[4730] 535 242					
98											
[28]	[270] 30 268	[1150] 130 267	[2050] 230 265	[2930] 330 264	[3790] 430 261	[4650] 525 259					
106											
[30]	[180] 20 287	[1060] 120 286	[1960] 220 284	[2850] 320 283	[3710] 420 281	[4570] 515 277					
114											
[35]		[840] 95 335	[1760] 200 334	[2640] 300 333	[3480] 395 332						
132											

[1760]
200
334 } Torque [lb-in]
Nm
Speed RPM

2000 Series

Dimensions

Ports

- 7/8 -14 UNF-2B SAE O-ring Staggered Ports (2)
- 7/16 -20 UNF-2B SAE O-ring Case Drain Port (1) or
- 1 1/16 -12 UN-2B SAE O-ring Ports (Positioned 180° Apart) (2)
- 7/16 -20 UNF-2B SAE O-ring Case Drain Port (1) or
- 7/8 -14 UNF-2B SAE O-ring End Ports (2)
- 7/16 -20 UNF-2B SAE O-ring Case Drain Port (1) or
- G 1/2 (BSP) Staggered Ports (2)
- G 1/4 (BSP) Case Drain Port (1) or
- Manifold Mount
- 7/16 -20 UNF-2B SAE O-ring Case Drain Port (1)

Standard Rotation Viewed from Shaft End

- Port A Pressurized — CW
- Port B Pressurized — CCW

Standard Mount

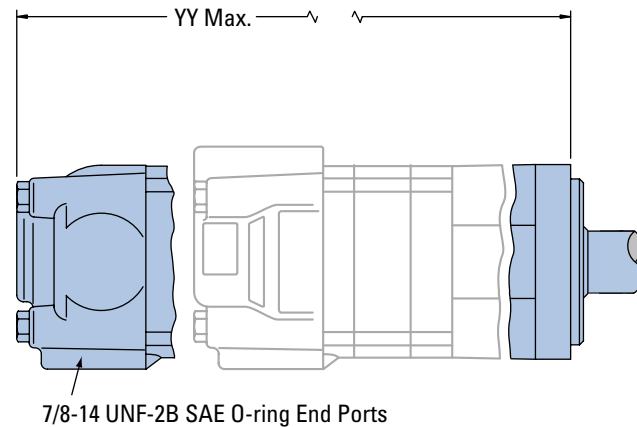
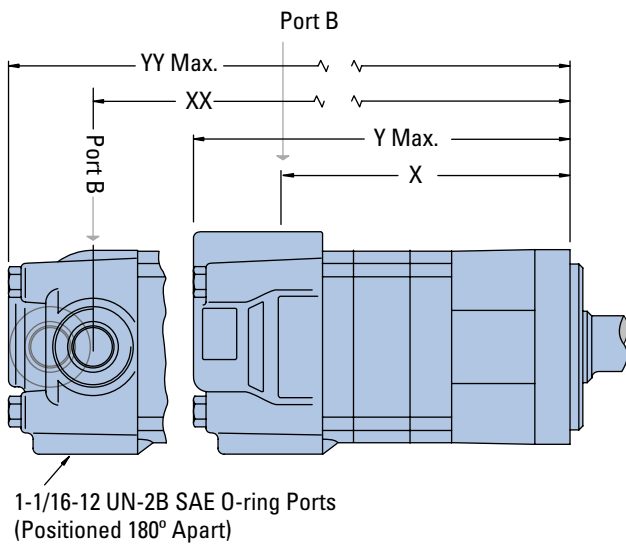

STANDARD MOUNT MOTOR DIMENSIONS

Displacement cm ³ /r [in ³ /r]	X mm [inch]	Y mm [inch]	XX mm [inch]	YY mm [inch]
80 [4.9]	136,9 [5.39]	184,2 [7.25]	139,2 [5.48]	185,4 [7.30]
100 [6.2]	141,5 [5.57]	189,0 [7.44]	143,8 [5.66]	190,3 [7.49]
130 [8.0]	147,9 [5.83]	195,4 [7.69]	150,2 [5.92]	196,6 [7.74]
160 [9.6]	147,9 [5.83]	195,4 [7.69]	150,2 [5.92]	196,6 [7.74]
195 [11.9]	154,7 [6.09]	202,2 [7.96]	157,0 [6.18]	203,2 [8.00]
245 [14.9]	163,7 [6.45]	211,1 [8.31]	166,0 [6.54]	212,4 [8.36]
305 [18.7]	175,1 [6.90]	222,3 [8.75]	177,4 [6.99]	223,5 [8.80]
395 [24.0]	191,0 [7.52]	238,6 [9.39]	193,3 [7.61]	239,8 [9.44]
490 [29.8]	208,4 [8.21]	255,8 [10.07]	210,7 [8.30]	270,1 [10.12]

2000 Series

Dimensions

Ports

7/8 -14 UNF-2B SAE O-ring Staggered Ports (2)
 7/16 -20 UNF-2B SAE O-ring Case Drain Port (1) or

G 1/2 (BSP) Staggered Ports (2)

G 1/4 (BSP) Case Drain Port (1)

Standard Rotation Viewed from Shaft End

Port A Pressurized — CW

Port B Pressurized — CCW

Standard Mount with Integral Relief Valve

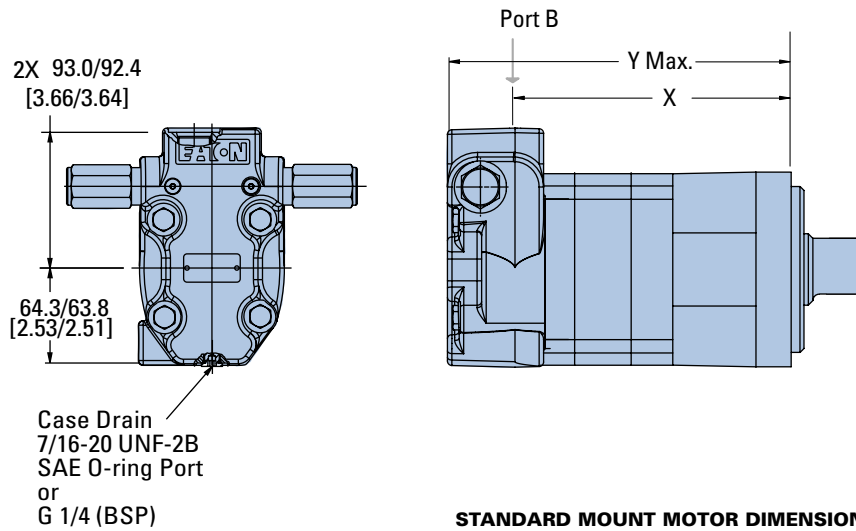

STANDARD MOUNT MOTOR DIMENSIONS

Displacement cm ³ /r [in ³ /r]	X mm [inch]	Y mm [inch]
80 [4.9]	137,0 [5.40]	184,5 [7.26]
100 [6.2]	141,6 [5.58]	189,0 [7.44]
130 [8.0]	147,9 [5.83]	195,4 [7.69]
160 [9.6]	147,9 [5.83]	195,4 [7.69]
195 [11.9]	154,8 [6.10]	202,2 [7.96]
245 [14.9]	163,7 [6.45]	211,1 [8.31]
305 [18.7]	175,1 [6.90]	222,6 [8.76]
395 [24.0]	191,1 [7.53]	238,6 [9.39]
490 [29.8]	208,4 [8.21]	255,8 [10.07]

2000 Series

Dimensions

Ports

- 7/8 -14 UNF-2B SAE O-ring Staggered Ports (2)
- 7/16 -20 UNF-2B SAE O-ring Case Drain Port (1) or
- 1 1/16 -12 UN-2B SAE O-ring Ports (Positioned 180° Apart) (2)
- 7/16 -20 UNF-2B SAE O-ring Case Drain Port (1) or
- 7/8 -14 UNF-2B SAE O-ring End Ports (2)
- 7/16 -20 UNF-2B SAE O-ring Case Drain Port (1) or
- G 1/2 (BSP) Staggered Ports (2)
- G 1/4 (BSP) Case Drain Port (1) or
- Manifold Mount
- 7/16 -20 UNF-2B SAE O-ring Case Drain Port (1)

Standard Rotation Viewed from Shaft End

- Port A Pressurized — CW
- Port B Pressurized — CCW

Wheel Mount

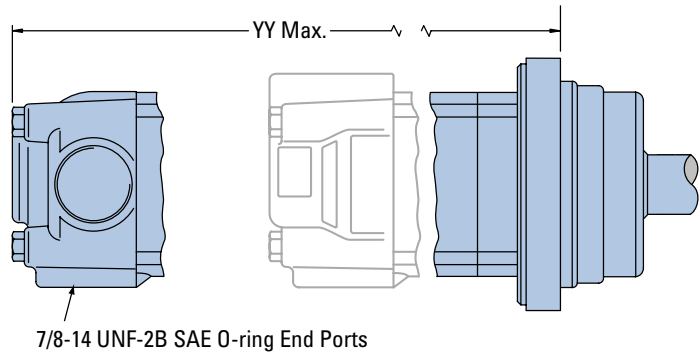
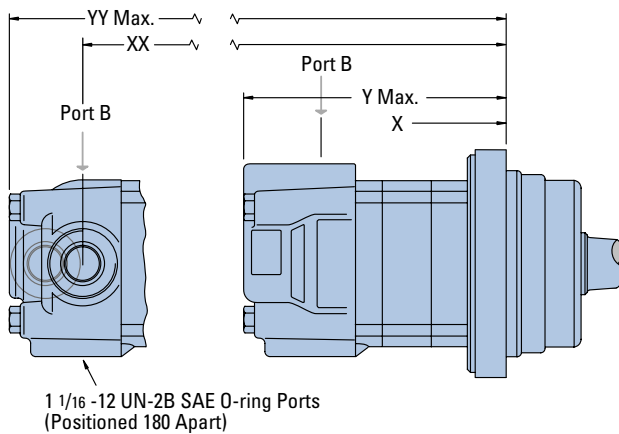

WHEEL MOUNT MOTOR DIMENSIONS

Displacement	X	Y	XX	YY
cm ³ /r [in ³ /r]	mm [inch]	mm [inch]	mm [inch]	mm [inch]
80 [4.9]	96,8 [3.81]	144,0 [5.67]	99,1 [3,90]	145,3 [5.72]
100 [6.2]	101,3 [3.99]	148,9 [5.86]	103,6 [4.08]	150,2 [5.91]
130 [8.0]	107,8 [4.25]	155,2 [6.11]	110,1 [4.34]	156,5 [6.16]
160 [9.6]	107,8 [4.25]	155,2 [6.11]	110,1 [4.34]	156,5 [6.16]
195 [11.9]	114,6 [4.51]	161,8 [6.37]	116,8 [4.60]	163,1 [6.42]
245 [14.9]	123,5 [4.87]	171,0 [6.73]	125,8 [4.96]	172,3 [6.78]
305 [18.7]	135,0 [5.32]	182,1 [7.17]	137,4 [5.41]	183,4 [7.22]
395 [24.0]	150,9 [5.94]	198,4 [7.81]	153,2 [6.03]	199,7 [7.86]
490 [29.8]	168,2 [6.63]	215,7 [8.49]	170,7 [6.72]	217,0 [8.54]

2000 Series

Dimensions

Ports

7/8 -14 UNF-2B SAE O-ring Staggered Ports (2)
 7/16 -20 UNF-2B SAE O-ring Case Drain Port (1)

G 1/2 (BSP) Staggered Ports (2)

G 1/4 (BSP) Case Drain Port (1)

Standard Rotation Viewed from Shaft End

Port A Pressurized — CW

Port B Pressurized — CCW

Wheel Mount with Integral Relief Valve

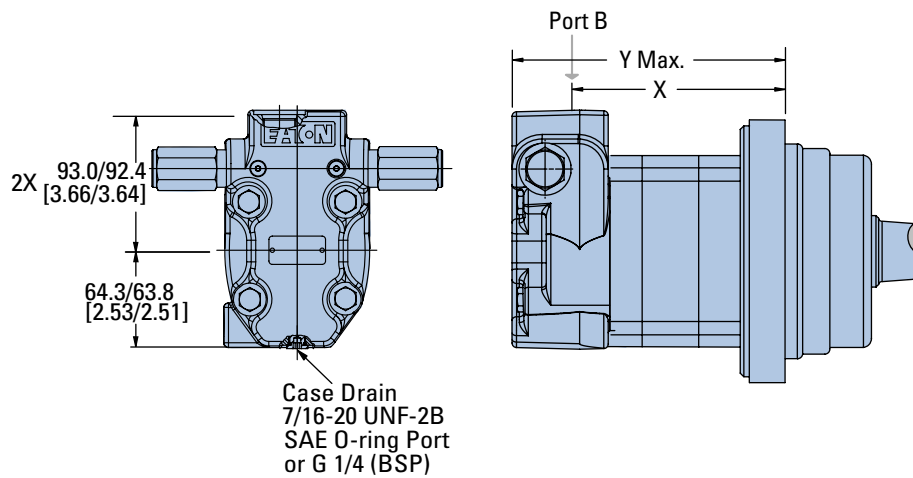

WHEEL MOUNT MOTOR DIMENSIONS

Displacement cm ³ /r [in ³ /r]	X mm [inch]	Y mm [inch]
80 [4.9]	96,9 [3.82]	144,3 [5.68]
100 [6.2]	101,4 [4.00]	148,9 [5.86]
130 [8.0]	107,8 [4.25]	155,2 [6.11]
160 [9.6]	107,8 [4.25]	155,2 [6.11]
195 [11.9]	114,6 [4.52]	162,1 [6.38]
245 [14.9]	123,5 [4.87]	171,0 [6.73]
305 [18.7]	135,0 [5.32]	182,4 [7.18]
395 [24.0]	151,0 [5.95]	198,4 [7.81]
490 [29.8]	168,2 [6.63]	215,7 [8.49]

2000 Series

Dimensions

Bearingless

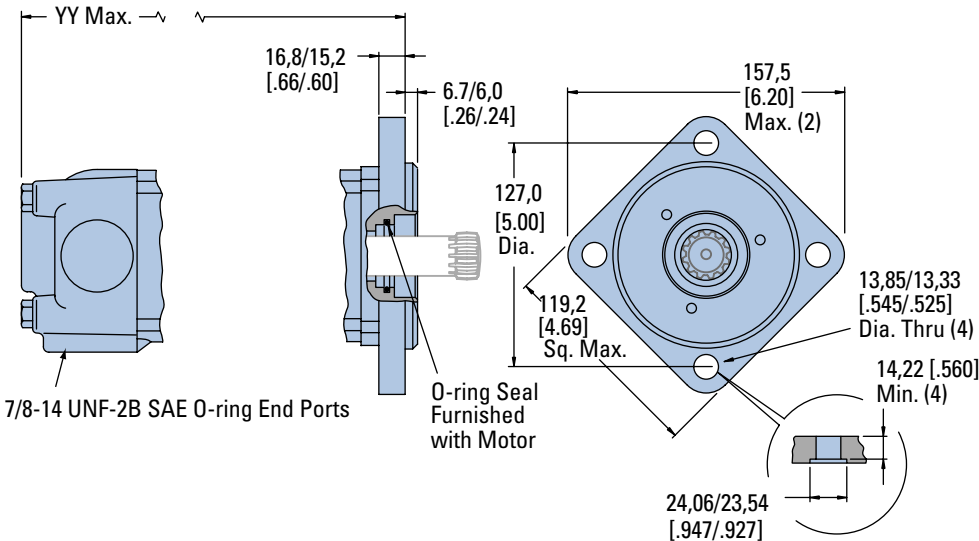
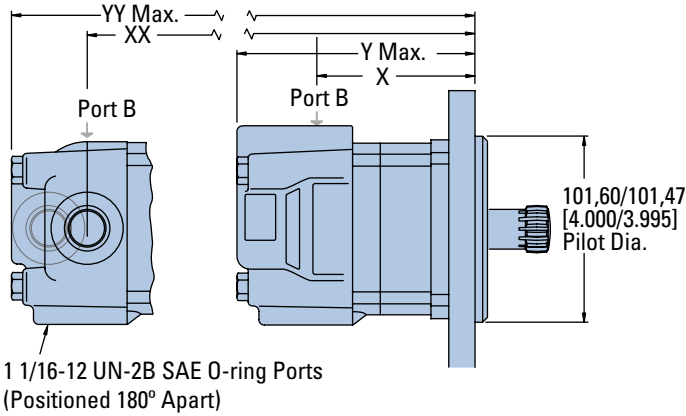

Ports

- 7/8 -14 UNF-2B SAE O-ring Staggered Ports (2)
- 7/16 -20 UNF-2B SAE O-ring Case Drain Port (1) or
- 1 1/16 -12 UN-2B SAE O-ring Ports (Positioned 180° Apart) (2)
- 7/16 -20 UNF-2B SAE O-ring Case Drain Port (1) or
- 7/8 -14 UNF-2B SAE O-ring End Ports (2)
- 7/16 -20 UNF-2B SAE O-ring Case Drain Port (1) or
- G 1/2 (BSP) Staggered Ports (2)
- G 1/4 (BSP) Case Drain Port (1) or
- Manifold Mount
- 7/16 -20 UNF-2B SAE O-ring Case Drain Port (1)

Standard Rotation Viewed from Shaft End

- Port A Pressurized — CW
- Port B Pressurized — CCW

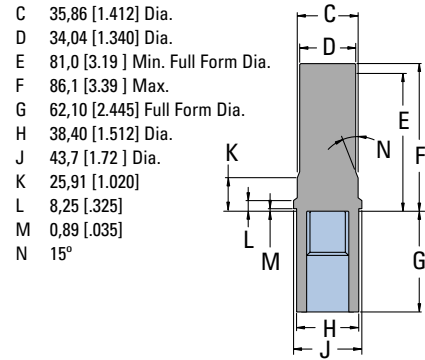

- C 35,86 [1.412] Dia.
- D 34,04 [1.340] Dia.
- E 81,0 [3.19] Min. Full Form Dia.
- F 86,1 [3.39] Max.
- G 62,10 [2.445] Full Form Dia.
- H 38,40 [1.512] Dia.
- J 43,7 [1.72] Dia.
- K 25,91 [1.020]
- L 8,25 [.325]
- M 0,89 [.035]
- N 15°

Mating Coupling Blank
Eaton Part No. 13307-003

For 2000 Series Bearingless Motor application information contact your Eaton representative (mating coupling blanks available from Eaton Hydraulics).

Note:

After machining blank, part must be hardened per Eaton specification.

BEARINGLESS MOTOR DIMENSIONS

Displacement cm ³ /r [in ³ /r]	X mm [inch]	Y mm [inch]	XX mm [inch]	YY mm [inch]
80 [4.9]	79,0 [3.11]	126,5 [4.98]	81,3 [3.20]	127,8 [5.03]
100 [6.2]	83,5 [3.29]	131,4 [5.17]	85,8 [3.38]	132,6 [5.22]
130 [8.0]	89,9 [3.54]	137,7 [5.42]	92,2 [3.63]	139,0 [5.47]
160 [9.6]	89,9 [3.54]	137,7 [5.42]	92,2 [3.63]	139,0 [5.47]
195 [11.9]	96,8 [3.81]	144,3 [5.68]	99,0 [3.90]	145,5 [5.73]
245 [14.9]	105,6 [4.16]	153,5 [6.04]	107,9 [4.25]	154,7 [6.09]
305 [18.7]	117,1 [4.61]	164,6 [6.48]	119,4 [4.70]	165,9 [6.53]
395 [24.0]	133,1 [5.24]	180,9 [7.12]	135,4 [5.33]	182,1 [7.17]
490 [29.8]	150,3 [5.92]	198,2 [7.80]	152,7 [6.01]	199,3 [7.85]

2000 Series

Dimensions

Ports

7/8 -14 UNF-2B SAE O-ring Staggered Ports (2)
 7/16 -20 UNF-2B SAE O-ring Case Drain Port (1)

G 1/2 (BSP) Staggered Ports (2)

G 1/4 (BSP) Case Drain Port (1)

Standard Rotation Viewed from Shaft End

Port A Pressurized — CW

Port B Pressurized — CCW

Bearingless with Integral Relief Valve

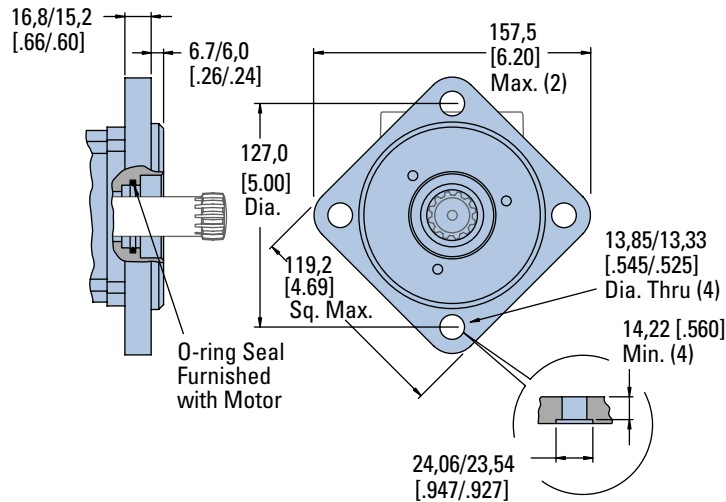
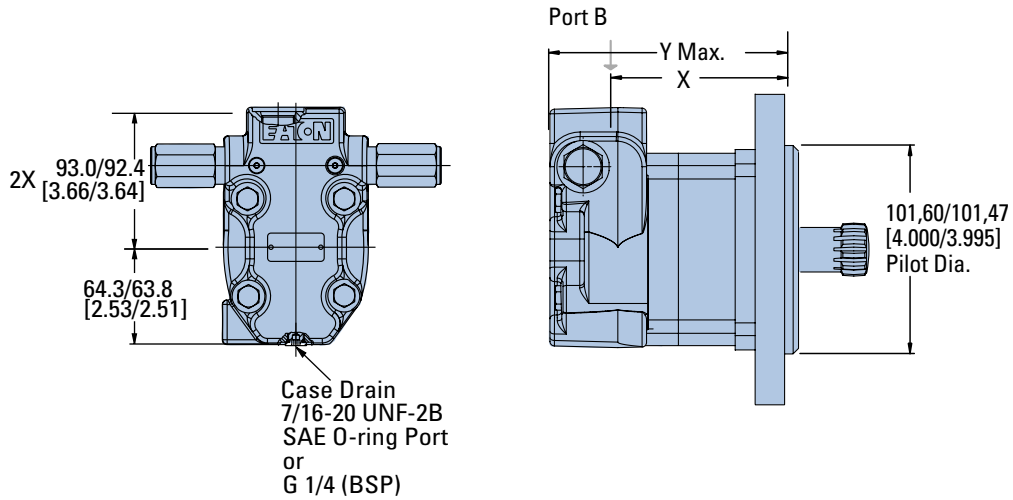

BEARINGLESS MOTORS DIMENSIONS

Displacement cm ³ /r [in ³ /r]	X mm [inch]	Y mm [inch]
80 [4.9]	79,0 [3.11]	126,8 [4.99]
100 [6.2]	83,5 [3.29]	131,4 [5.17]
130 [8.0]	89,9 [3.54]	137,7 [5.42]
160 [9.6]	89,9 [3.54]	137,7 [5.42]
195 [11.9]	96,8 [3.81]	144,6 [5.69]
245 [14.9]	105,6 [4.16]	153,5 [6.04]
305 [18.7]	117,1 [4.61]	164,9 [6.49]
395 [24.0]	133,1 [5.24]	180,9 [7.12]
490 [29.8]	150,3 [5.92]	198,2 [7.80]

2000 Series

Installation Information

Bearingless

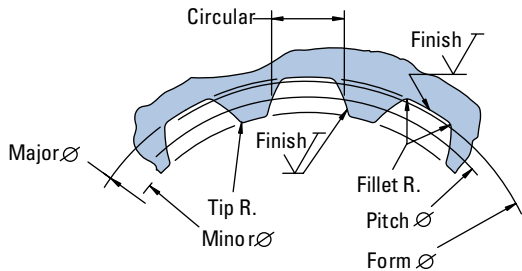
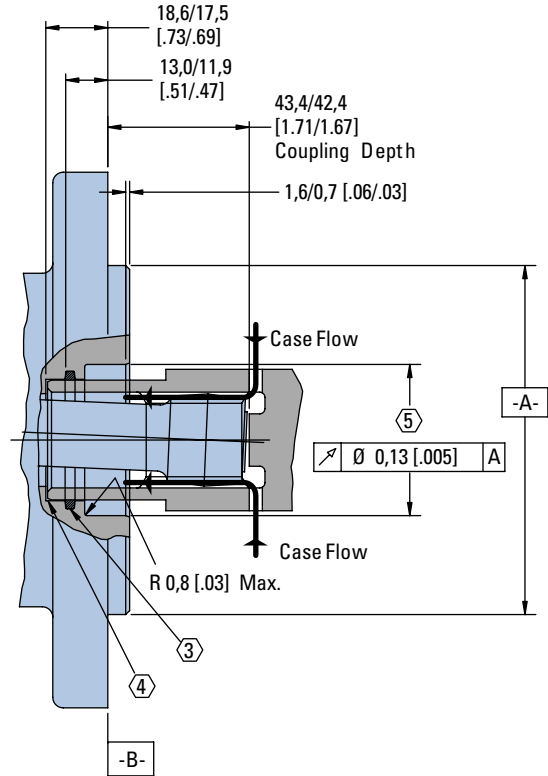
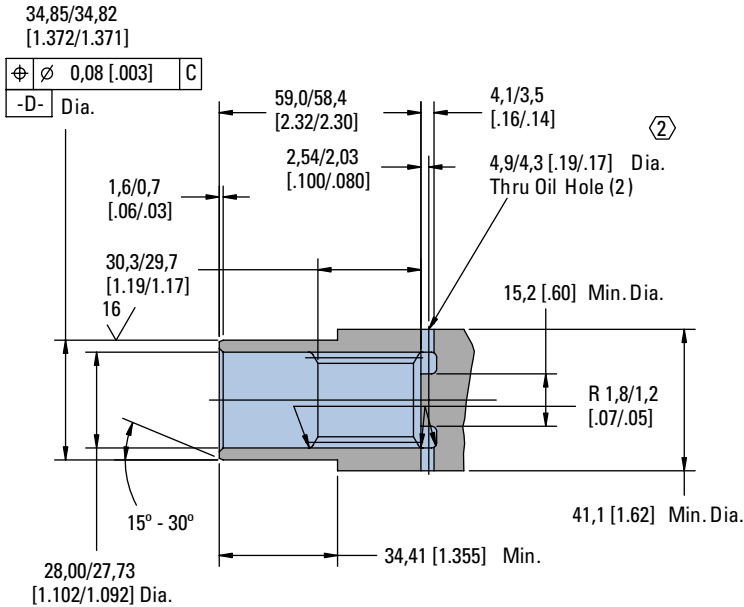

- ① Internal spline in mating part to be per spline data. Specification material to be ASTM A304, 8620H vacuum degassed alloy steel carbonize to a hardness of 59-62 HRc with case depth (to 50HRc) of 0,076 -1,02 [.030 -0.040]. Dimensions apply after heat treat.
- ② Mating part to have critical dimensions as shown. Oil holes must be provided and open for proper oil circulation.
- ③ Seal to be furnished with motor for proper oil circulation thru splines.
- ④ Some means of maintaining clearance between shaft and mounting flange must be provided.
- ⑤ Counterbore designed to adapt a standard sleeve bearing 35,010 -35,040 [1.3784 -1.3795] I.D. by 44,040 -44,070 [1.7339 -1.7350] O.D. (Oilite Bronze Sleeve Bearing AAM3544-22).

Spline Pitch	12/24
Pressure Angle	30°
Number of teeth	12
Class of Fit	Ref. 5
Type of Fit	Side
Pitch Diameter	Ref. 25,400000 [1.0000000]
Base Diameter	Ref. 21,997045 [0.8660254] ⊕ 0,21 [.008] D
Major Diameter	(27,74 [1.092] Max. 27,59 [1.086] Min.)
Minor Diameter	23,097 - 23,224 [.9093 - .9143]
Form Diameter, Min.	29,93 [1.060]
Fillet Radius	0,64 - 0,76 [.025 - .030]
Tip Radius	0,25 - 0,38 [.010 - .015]
Finish	1,6 (63)
Involute Profile Variation	+0,000 -0,025 [+0.000 -0.010]
Total Index Variation	0,038 [.0015]
Lead Variation	0,013 [.0005]
Circular Space Width:	
Maximum Actual	4,318 [0.1700]
Minimum Effective	4,216 [0.1660]
Maximum Effective	Ref. 4,270 [0.1681]
Minimum Actual	Ref. 4,247 [0.1672]
Dimension Between Two Pins	Ref. 19,020 - 19,190 [0.7488 - 0.7555]
Pin Diameter	4,496 [0.1770] Pins to Have 3,38 [.133]
	Wide Flat for Root Clearance

2000 Series

Dimensions

Mounting Options

SAE A — Two Bolt (Standard Motor)

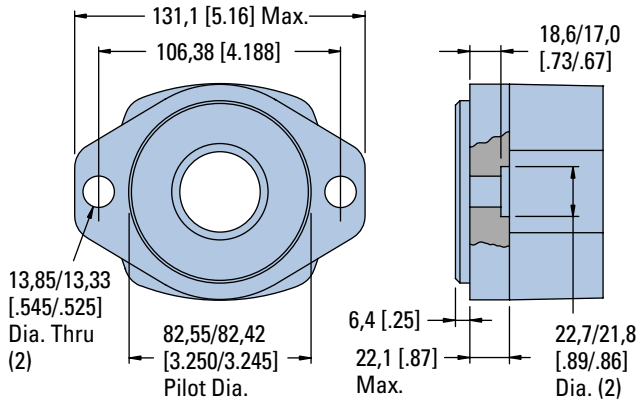

SAE B — Two Bolt

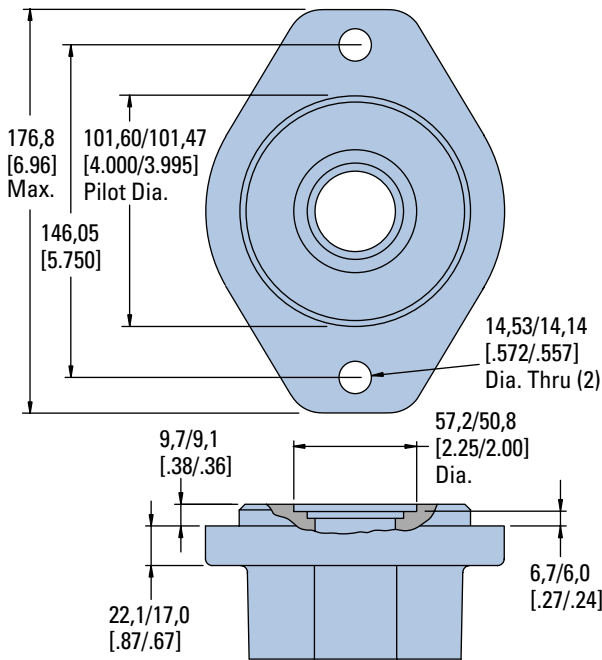

Four Bolt

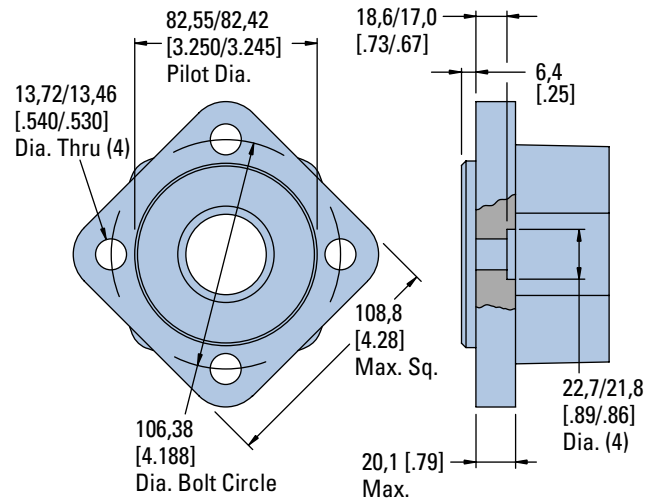

Four Bolt Magneto

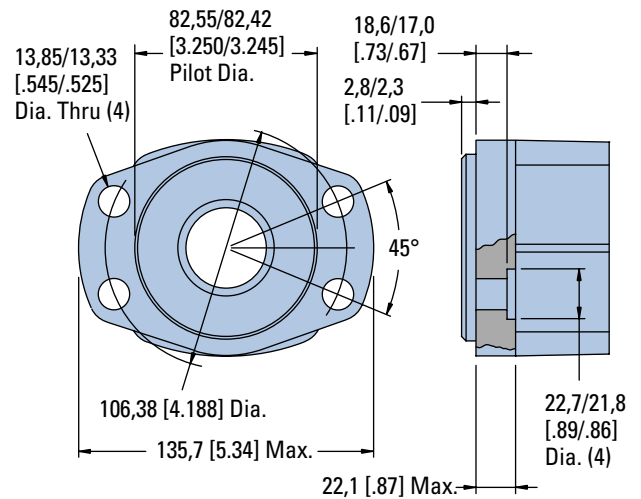

Four Bolt (Wheel Motor)

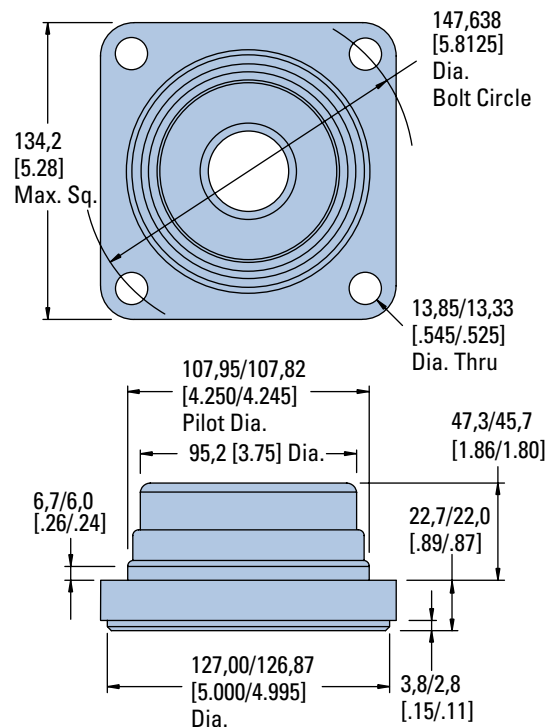

2000 Series

Dimensions

Shafts

1 Inch Straight

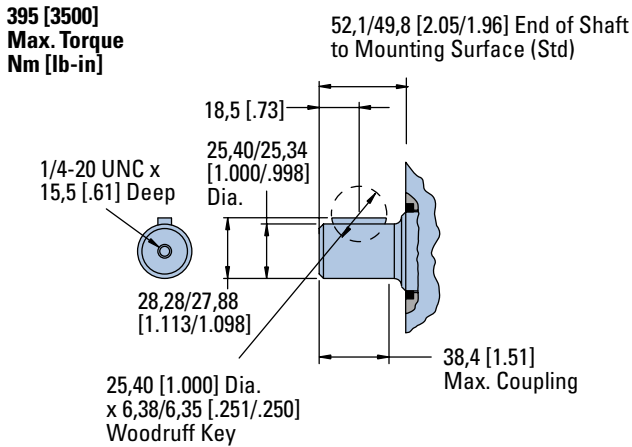

1 1/4 Inch Tapered

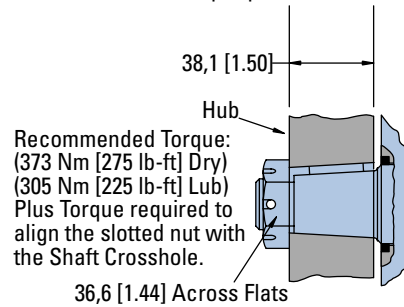
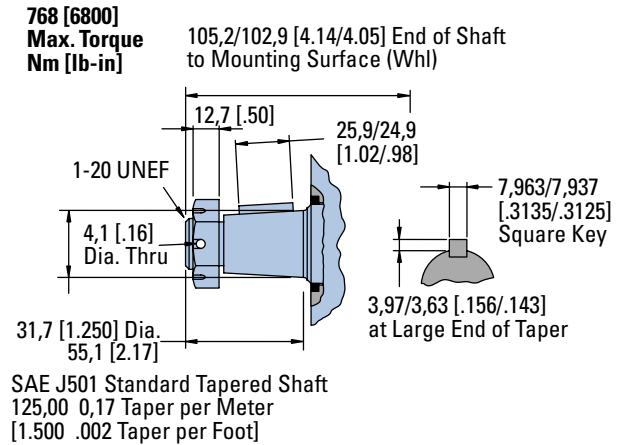

1 1/4 Inch Straight

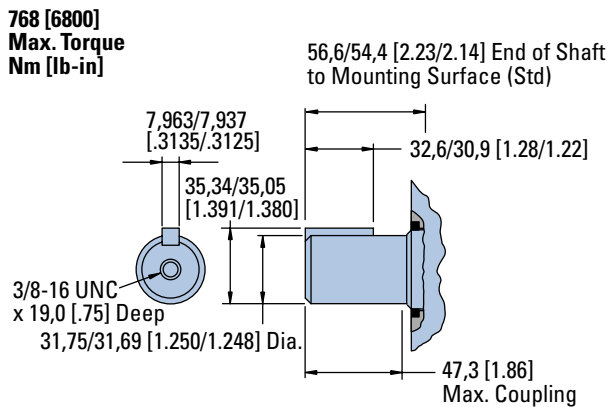

25 mm Straight

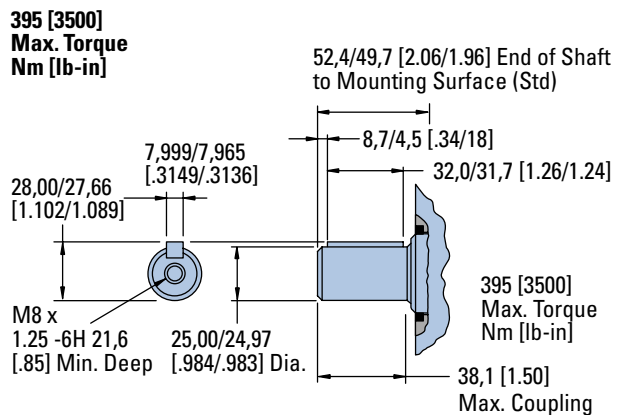

2000 Series

Dimensions

Shafts

32 mm Straight

**768 [6800]
Max. Torque
Nm [lb-in]**

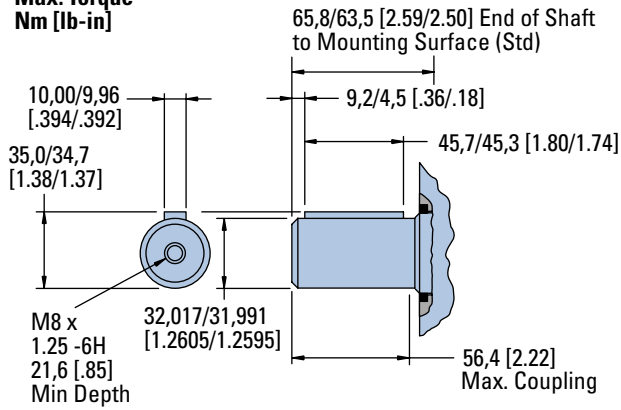

SAE 6B Splined

**395 [3500]
Max. Torque
Nm [lb-in]**

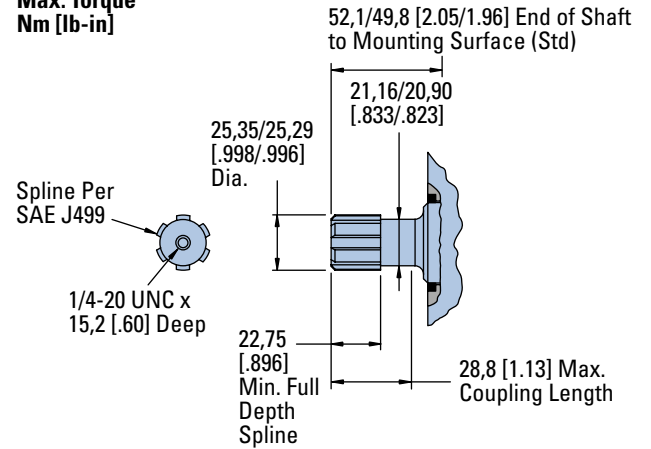

1 1/4 -14 Tooth Splined

**768 [6800]
Max. Torque
Nm [lb-in]**

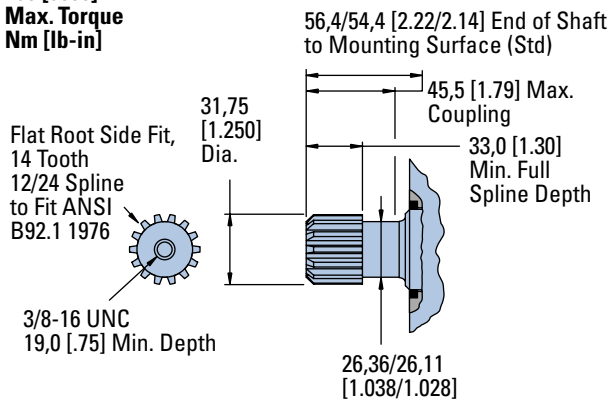

13 Tooth Splined

**141 [1250]
Max. Torque
Nm [lb-in]**

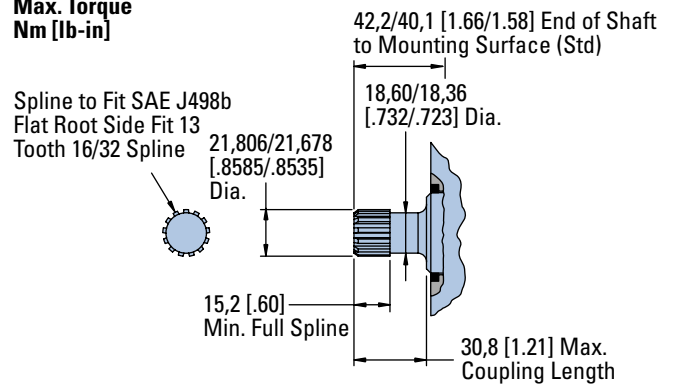

2000 Series

Shaft Side Load Capacity

These curves indicate the radial load capacity on the motor shaft(s) at various locations with an allowable external thrust load of 454 kg [1000 lb].

Note:

Case pressure will increase the allowable inward thrust load and decrease the allowable outward thrust load. Case pressure will push outward on the shaft at 61 kg/7 Bar [135 lb/100 PSI].

Each curve is based on

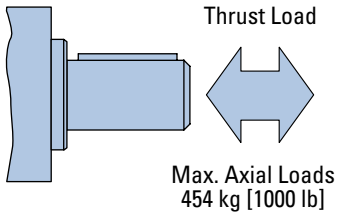

B 10 bearing life (2000 hours of 12,000,000 shaft revolutions at 100 RPM) at rated output torque.

To determine radial load at speeds other than 100 RPM, multiply the load values given on the bearing curve by the factors in the chart below.

RPM	Multiplication Factor
50	1.23
100	1.00
200	0.81
300	0.72
400	0.66
500	0.62
600	0.58
700	0.56
800	0.54

For 3,000,000 shaft revolutions or 500 hours—Increase these shaft loads 52%.

**Standard Motor
Straight and Splined Shafts**

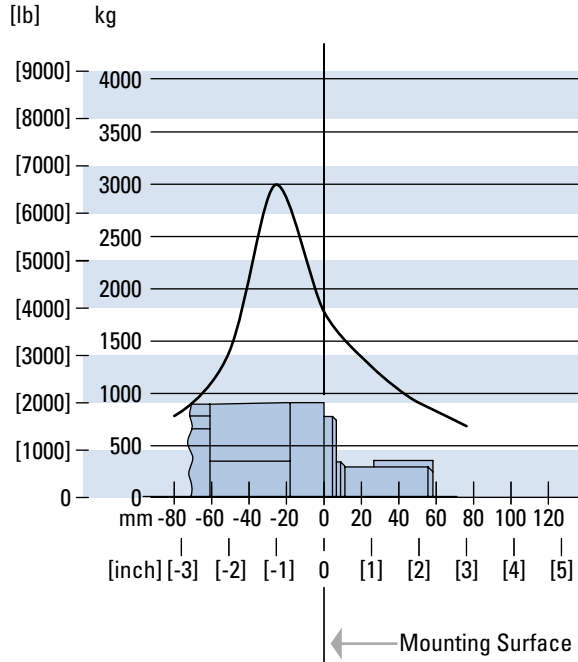

**Wheel Motor
Tapered Shaft**

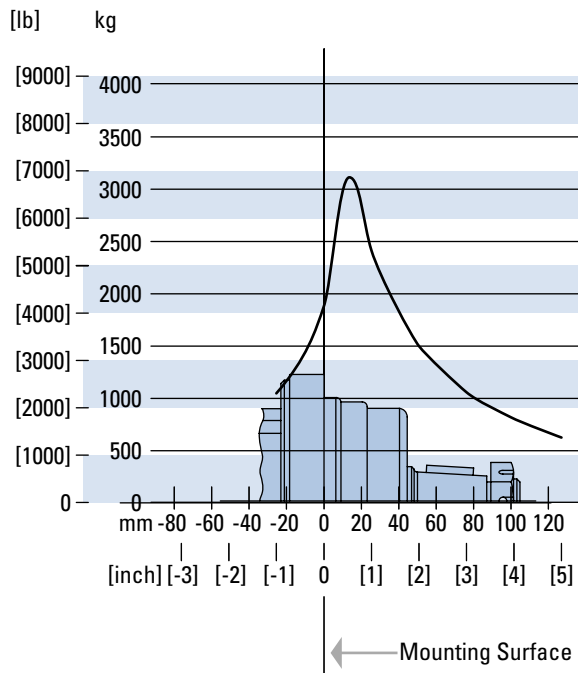

2000 Series

Case Pressure and Case Porting

Char-Lynn 2000 Series motors are durable and have long life as long as the recommended case pressure is not exceeded. Allowable case pressure is highest at low shaft speeds. Consequently, motor life will be shortened if case pressure exceeds these ratings (acceptability may vary with application). Determine if an external case drain is required from the case pressure seal limitation chart.

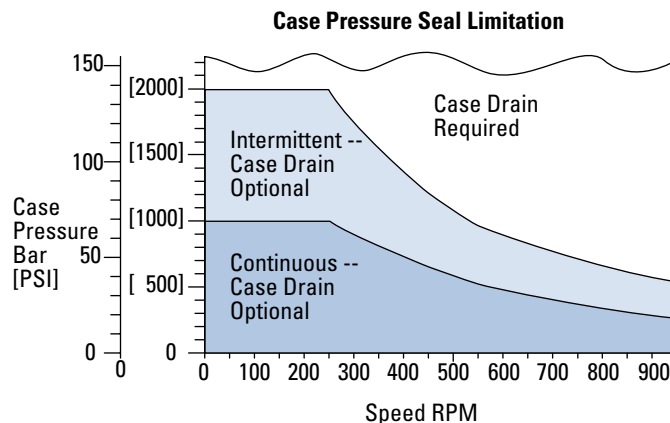

Case Porting Advantage

Contamination Control — flushing the motor case.

Cooler Motor — exiting oil draws motor heat away.

Extend Motor Seal Life — maintain low case pressure with a preset restriction in the case drain line.

2000 Series

Dimensions

Ports

7/8-14 UNF-2B SAE O-ring Ports (2) or G 1/2 (BSP) Ports (2)

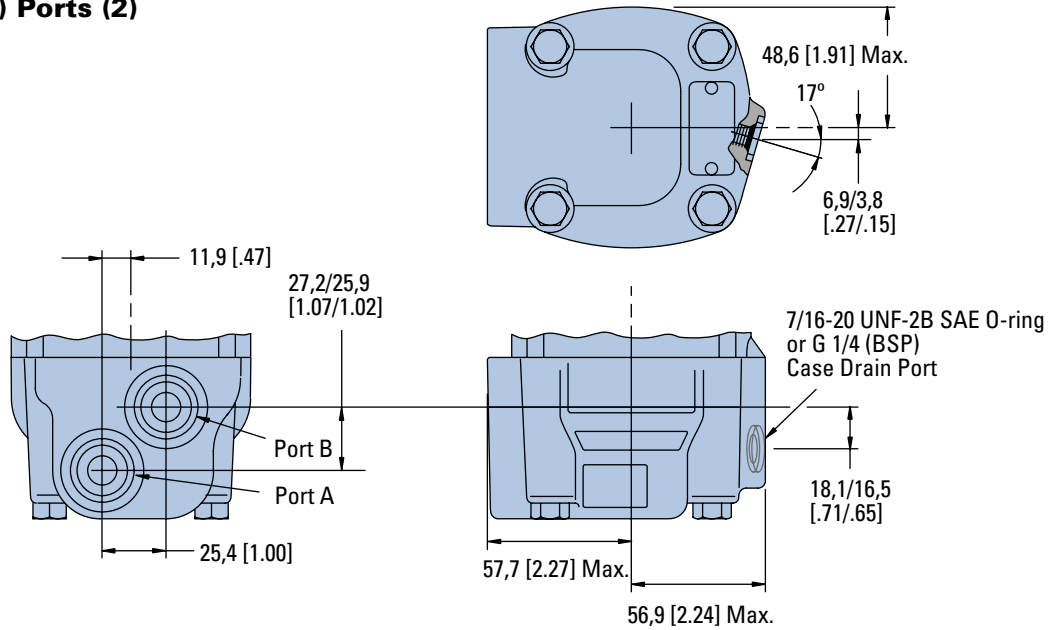

Manifold Mount

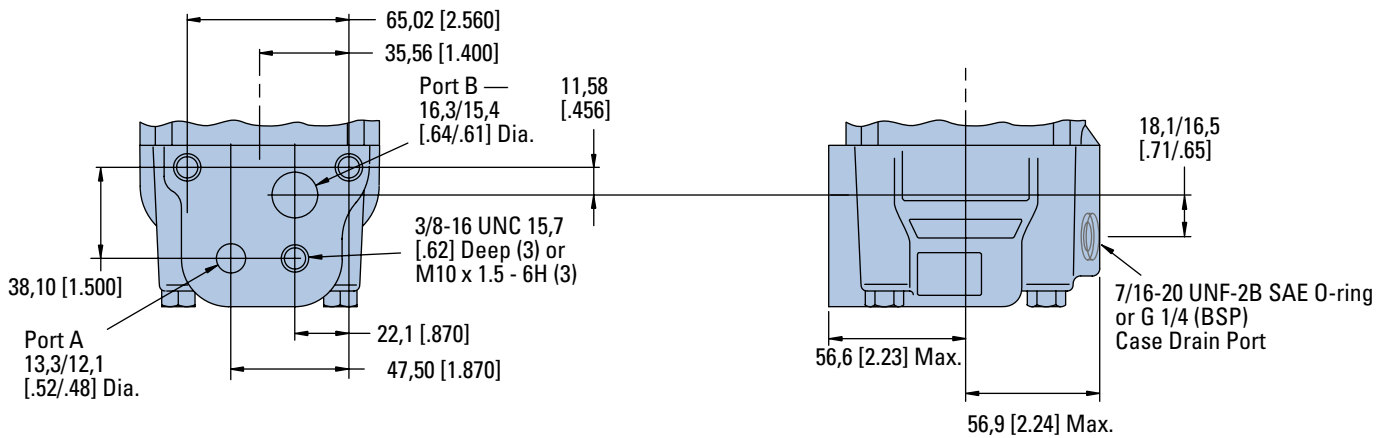

2000 Series

Dimensions

Ports

1-1/16-12 UN-2B SAE O-ring Ports (2) Positioned 180° Apart

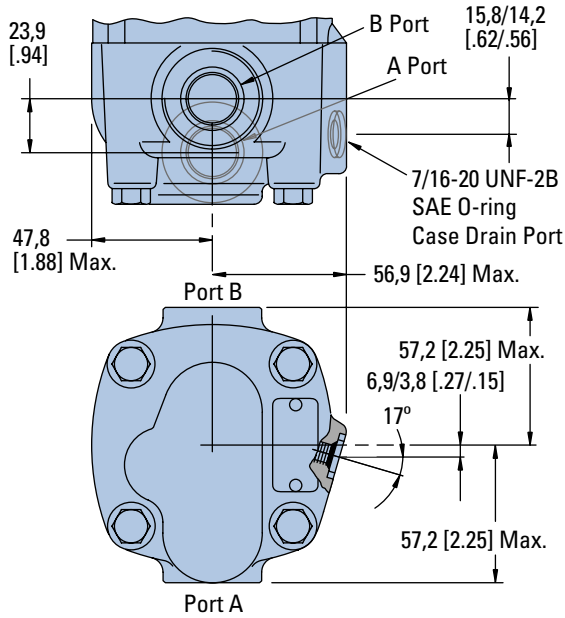

7/8-14 UNF-2B SAE O-ring End Ports (2)

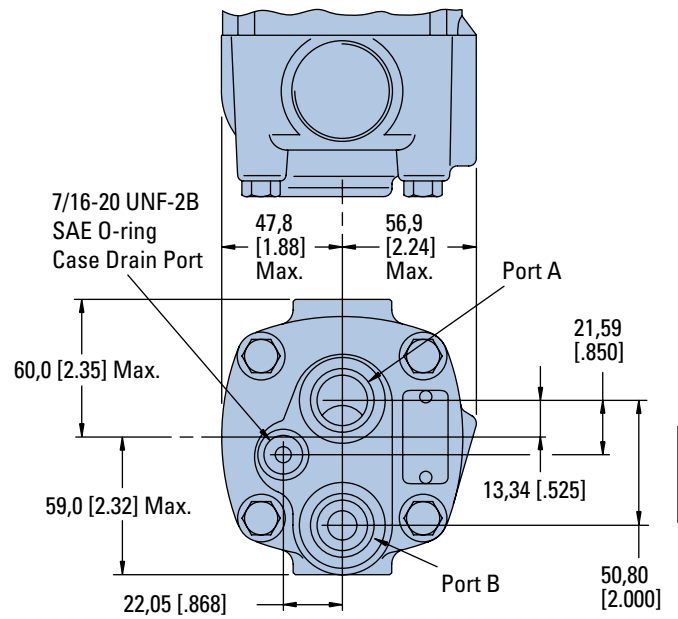

2000 Series

Dimensions

Ports with Shuttle

7/8 -14 UNF-2B SAE O-ring Ports (2) or G 1/2 (BSP) Ports (2)

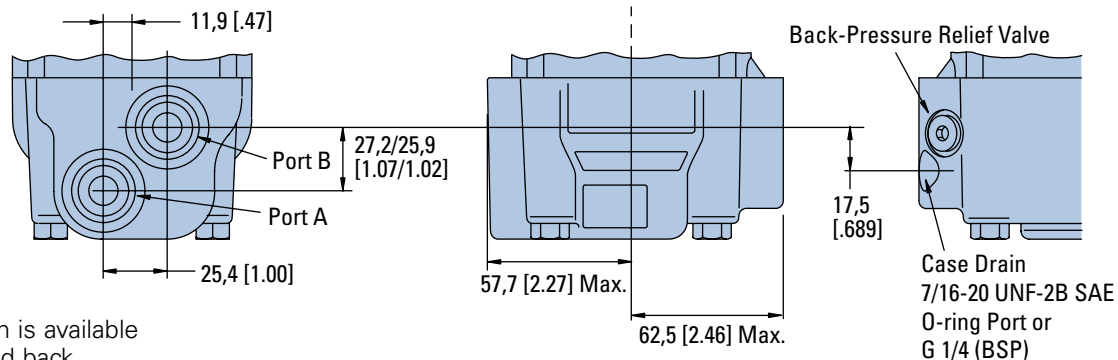

This port option is available with shuttle and back pressure relief valve for closed loop applications.

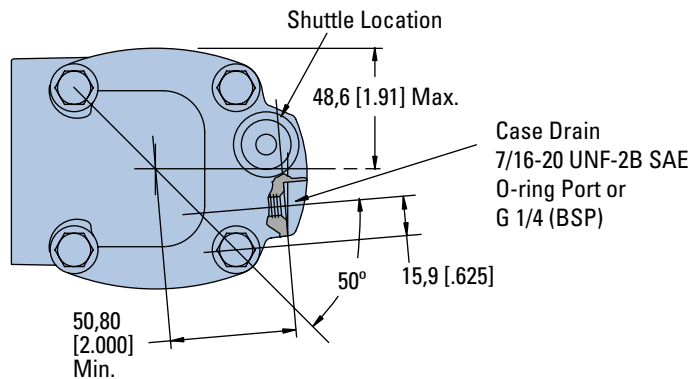

7/8 -14 UNF-2B SAE O-ring End Ports (2)

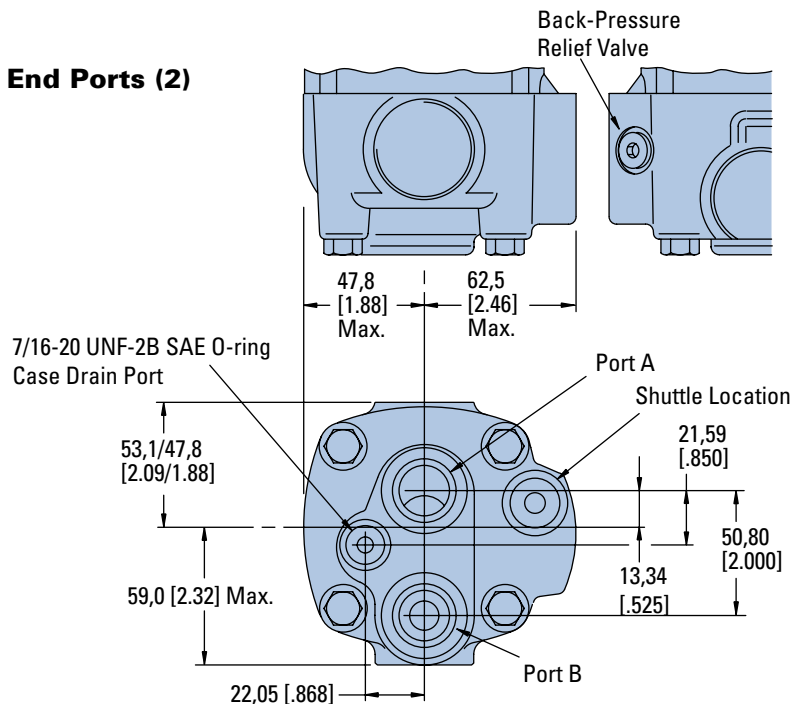

This port option is available with shuttle and back pressure relief valve for closed loop applications.

2000 Series

Product Numbers

Note:

For 2000 Series Motors with a configuration **Not Shown** in the charts below: Use model code number system on the next page to specify product in detail.

Use digit prefix — 104-, 105-, or 106- plus four digit number from charts for complete product number— Example 106-1043.

Orders will not be accepted without three digit prefix.

MOUNTING	SHAFT	PORT SIZE	DISPL. cm ³ /r [in ³ /r] / PRODUCT NUMBER									
			80 [4.9]	90* [5.5]	100 [6.2]	130 [8.0]	160 [9.6]	195 [11.9]	245 [14.9]	305 [18.7]	395 [24.0]	490 [29.8]
2 Bolt SAE A Flange	1 Inch Straight	7/8 -14 O-ring Staggered	104-1001	—	-1002	-1003	-1004	-1005	-1006	-1007	-1143	—
		1 1/16 -12 O-ring 180° Apart	104-1037	—	-1038	-1039	-1040	-1041	-1042	-1043	-1044	—
	1 1/4 Inch Straight	7/8 -14 O-ring Staggered	104-1022	—	-1023	-1024	-1025	-1026	-1027	-1028	-1228	-1420
		1 1/16 -12 O-ring 180° Apart	104-1061	—	-1062	-1063	-1064	-1065	-1066	-1067	-1068	-1421
	1 1/4 Inch 14 T Splined	7/8 -14 O-ring Staggered	104-1029	—	-1030	-1031	-1032	-1033	-1034	-1035	-1229	-1422
		1 1/16 -12 O-ring 180° Apart	104-1087	—	-1088	-1089	-1090	-1091	-1092	-1093	-1094	-1423
2 Bolt SAE B Flange	1 1/4 Inch Straight	7/8 -14 O-ring Staggered	104-1200	—	-1201	-1202	-1203	-1204	-1205	-1206	-1207	—
	1 1/4 Inch Involute SAE C Splined	7/8 -14 O-ring Staggered	104-1208	—	-1209	-1210	-1211	-1212	-1213	-1214	-1215	—
	1 Inch SAE 6B Splined	7/8 -14 O-ring Staggered	104-1193	—	-1194	-1195	-1196	-1197	-1198	-1199	—	—
	7/8 Inch SAE B Splined	7/8 -14 O-ring Staggered	104-1216	—	-1217	-1218	-1219	-1220	—	—	—	—
	32 mm Straight	G 1/2 (BSP)	104-1384	—	-1385	-1386	-1387	-1388	-1389	-1390	-1391	—
	1 1/4 Inch 14 T Splined	G 1/2 (BSP)	104-1376	—	-1377	-1378	-1379	-1380	-1381	-1382	-1383	—
Wheel Motor	1 1/4 Inch Straight	7/8 -14 O-ring Staggered	105—	—	—	—	—	—	—	—	—	-1148
		1 1/16 -12 O-ring 180° Apart	105—	—	—	—	—	—	—	—	—	-1149
	32 mm Straight	G 1/2 (BSP)	105-1134	—	-1135	-1136	-1137	-1138	-1139	-1140	-1141	—
	1 1/4 Inch 14 T Splined	7/8 -14 O-ring Staggered	105-1001	—	-1002	-1003	-1004	-1005	-1006	-1007	-1060	-1152
		1 1/16 -12 O-ring 180° Apart	105-1071	—	-1072	-1073	-1074	-1075	-1076	-1077	-1078	—
	1 1/4 Inch Tapered	7/8 -14 O-ring Staggered	105-1029	—	-1030	-1031	-1032	-1033	-1034	-1035	-1096	—
1 1/16 -12 O-ring 180° Apart		105-1079	—	-1080	-1081	-1082	-1083	-1084	-1085	-1086	—	
Bearingless		7/8 -14 O-ring Staggered	106-1008	—	-1009	-1010	-1011	-1012	-1013	-1014	-1015	-1047
		G 1/2 (BSP)	106-1038	—	-1039	-1040	-1041	-1042	-1043	-1044	-1045	—

*New Release

106-1044

Motors with Corrosion Protection

MOUNTING	SHAFT	PORT SIZE	DISPL. cm ³ /r [in ³ /r] / PRODUCT NUMBER									
			80 [4.9]	90* [5.5]	100 [6.2]	130 [8.0]	160 [9.6]	195 [11.9]	245 [14.9]	305 [18.7]	395 [24.0]	490 [29.8]
2 Bolt SAE A Flange	1 inch Straight	7/8 -14 O-ring Staggered	104-1528	—	-1529	-1530	-1531	-1532	-1533	-1534	-1519	-1535
	1 1/4 Inch Straight	7/8 -14 O-ring	104-1516	—	-1536	-1537	-1538	-1539	-1452	-1479	-1509	-1489

*New Release

2000 Series

Model Code

The following 24-digit coding system has been developed to identify all of the configuration options for the 2000 Series motor. Use this model code to specify a motor with the desired features. All 24 digits of the code must be present when ordering. You may want to photocopy the matrix below to ensure that each number is entered in the correct box.

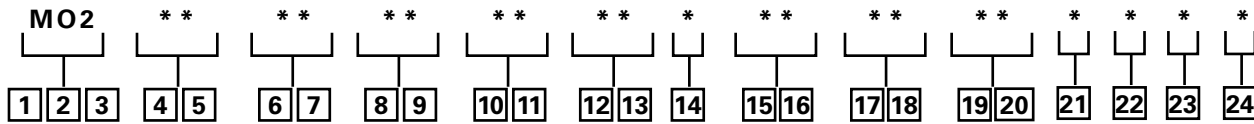

1, 2, 3 Product Series
MO2 – 2000 Series Motor

4, 5 Displacement
cm³/r [in³/r]

- 05** – 80 [4.9]
- A5** – 90 [5.5]
- 06** – 100 [6.2]
- 08** – 130 [8.0]
- 10** – 160 [9.6]
- 12** – 195 [11.9]
- 15** – 245 [14.9]
- 19** – 305 [18.7]
- 24** – 395 [24.0]
- 30** – 490 [29.8]

6, 7 Mounting Type

- AB** – 4 Bolt (Wheel) 108,0 [4.25] Pilot Dia. and 13,59 [.535] Dia. Mounting Holes on 147,6 [5.81] Dia. B.C.
- AC** – 2 Bolt SAE A (Std.) 82,5 [3.25] Pilot Dia and 13,59 [.535] Dia. Mtg. Holes on 106,4 [4.19] Dia. B.C.
- AD** – 4 Bolt (Bearingless) 101,6 [4.00] Pilot Dia. and 13,59 [.535] Dia. Mounting Holes on 127,0 [5.00] Dia. B.C.
- AF** – 2 Bolt SAE B (Std.) 101,6 [4.00] Pilot Dia. and 14,35 [.565] Dia. Mtg. Holes on 146,0 [5.75] Dia. B.C.
- AH** – 4 Bolt (Standard) 82,5 [3.25] Pilot Dia. and 14,59 [.535] Dia. Mounting Holes on 106,4 [4.19] Dia. B.C.
- AJ** – 4 Bolt Magneto (Std.) 82,5 [3.25] Pilot Dia. and 13,59 [.535] Dia. Mtg. Holes on 106,4 [4.19] Dia. B.C.
- AP** – 4 Bolt (wheel compatible for HAYES BRAKE) 107,9 [4.25] Pilot Dia. and 13,59 [.535] Dia. Mounting Holes on 147,6 [5.81] Dia. B.C. with Turned Down Housing to 88,9 [3.50] Dia.

8, 9 Output Shaft

- 00** – None (Bearingless)
- 01** – 1 inch Dia. Straight

with Woodruff Key, 1/4 -20 Threaded Hole and 38,4 [1.51] Max. Coupling Length

02 – 1 1/4 inch Dia. Straight with Straight Key, 3/8 -16 Threaded Hole and 47,3 [1.86] Max. Coupling Length

03 – 1 1/4 inch Dia. Tapered with Straight Key and Nut

04 – 1 1/4 inch Dia. Splined 14 T, 3/8 -16 Threaded Hole and 33,0 [1.30] Min. Full Spline Length and 45,5 [1.79] Max. Coupling Length

05 – 1 inch SAE 6B Splined 6T, 1/4 -20 Threaded Hole and 22,8 [.90] Min. Full Spline Length and 28,8 [1.13] Max. Coupling Length

07 – 7/8 inch Dia. Splined 13T, 15,2 [.60] Min. Full Spline Length and 30,8 [1.21] Max. Coupling Length

23 – 32 mm dia. Straight with Straight Key, M8 x 1,25 -6H Threaded Hole and 56,4 [2.22] Max. Coupling Length

24 – 1 1/4 inch Dia. Straight with Straight Key, 3/8 -16 Threaded Hole and Corrosion Resistant (seal area to shaft end)

25 – 1 1/4 inch Dia. Tapered with Straight Key and Nut, Corrosion Resistant (under seal area only)

26 – 25 mm Dia. Straight with Straight Key, M8 x 1,25 -6H Threaded Hole and 38,4 [1.51] Max. Coupling Length

10, 11 Ports

AA – 7/8 -14 UNF -2B SAE O-ring (Staggered)

AG – G 1/2 BSP Straight Thread ports (Staggered)

AB – Manifold Mount with 3/8 -16 UNC Mounting Threads (3)

AD – 7/8 -14 UNF -2B SAE O-ring (End Ports)

AE – Manifold Mount with M10 x 1,5 -6H Mounting

Threads (3)

AF – 1 1/16 - 12 UN-2B O-ring ports (Positioned 180° Apart)

12, 13 Case Flow Options

Shuttles available with port code AA or AD only)

01 – 7/16 -20 UNF -2B SAE O-ring (Case Drain)

02 – G 1/4 (BSP) Straight Thread Port (Case Drain)

04 – Shuttle Valve with 7/16 -20 UNF -2B SAE O-ring (Case Drain)

05 – Shuttle Valve with G 1/4 (BSP) straight thread port (Case Drain)

14 Low Pressure Relief

(LPR available with a combination of case flow code 04 or 05 and port code AA or AD only)

0 – None

A – Set at 4,5 bar [65 PSI] (for Manual Pumps)

B – Set at 15,2 bar [220 PSI] (for Servo Pumps)

C – Set at 20,7 bar [300 psi]

15, 16 Valve Options

00 – None

17, 18 Accessories

00 – None

AA – Seal Guard

AH – Speed Sensor (Std. With M12 connector)

AL – Quadrature Speed Sensor Version 2 with M1

19, 20 Special Features (Hardware)

00 – None

01 – Viton Seals

10 – Viton Shaft Seal

57 – 105 bar [1500 psi] Internal Cross Over Relief Valve (staggered 7/8" O-ring ports only)

58 – 120 bar [1750 psi] Internal Cross Over Relief Valve (staggered 7/8" O-ring ports only)

59 – 140 bar [2000 psi] Internal Cross Over Relief Valve (staggered 7/8" O-ring ports only)

60 – 155 bar [2250 psi] Internal Cross Over Relief Valve (staggered 7/8" O-ring ports only)

61 – 170 bar [2500 psi] Internal Cross Over Relief Valve (staggered 7/8" O-ring ports only)

62 – 190 bar [2750 psi] Internal Cross Over Relief Valve (staggered 7/8" O-ring ports only)

63 – 205 bar [3000 psi] Internal Cross Over Relief Valve (staggered 7/8" O-ring ports only) Seal

21 Special Features (Assembly)

0 – None

A – Flange Rotated 90°

B – Reverse Rotation

22 Paint/ Special Packaging

0 – No Paint, Individual Box

A – Painted Low Gloss Black, Individual Box

B – Corrosion Protected

23 Eaton Assigned Code when Applicable

0 – Assigned Code

24 Eaton Assigned Design Code

0 – Assigned Design Code

2000 Series Two-Speed

Description

The Eaton 2000 Series motors are available with an integral two speed feature that changes the displacement in a ratio of 1 to 2 and shifts the motor from a low speed high torque (LSHT) mode to a high speed low torque (HSLT) mode. The open center selector valve shifts the speed mode from low to high speed when pilot pressure of 6.9 Δ Bar [100 Δ PSI] minimum is applied to the pilot port (6.9 Bar [100 PSI] higher than case pressure). In the high speed mode torque values are approximately one half with twice the speed of the conventional 2000 Series single speed motors.

An external two position three way valve is required for shifting the pilot pressure port between signal pressure (HSLT) and low pressure (LSHT)

Two speed motors are available with a return line closed center shuttle for closed circuit applications. Low speed high torque mode is the normal position of the speed selector valve. When a differential pressure is supplied to the pilot port and 6.9 Bar [100 PSI] is reached, the selector valve overcomes the return spring force and the spool shifts to the high speed mode. The oil in the opposite side of the spool is drained internally. Pressure between the pilot supply and case drain or return line (depending on open or closed circuit system) must be maintained to keep the motor in the high speed mode.

When pilot pressure is removed from the pilot port the pressure in the pilot end of the spool valve is relieved and drained back through

this three way valve, the spring force returns the spool valve to LSHT position. Pilot pressure may come from any source that will provide uninterrupted pressure during the high speed mode operation. Pilot pressure 6.9 Δ Bar [100 Δ PSI] minimum, up to the full operating pressure of the motor.

In normal LSHT operation the Char-Lynn two speed motor will function with equal shaft output in either direction (CW or CCW), the same as the single speed Char-Lynn disc valve motors.

However, to prevent cavitation in the HSLT mode, the preferred direction of shaft rotation is counter clockwise (port B pressurized). This unique disc valve is not symmetrical in porting the fluid for the HSLT mode. Consequently, when the pressure is reversed for

HSLT CW rotation, cavitation can occur. Installing a restriction (200 psi or more depending on flow) in the hydraulic line that connects port B will prevent cavitation.

If you are operating in a critical area and a restriction in the hydraulic line causes concern, these two speed motors can be ordered timed with CW preferred HSLT shaft rotation. Hence, with this option port B will have to be pressurized for CW preferred HSLT shaft rotation. The restriction recommended for the line connecting port B remains unchanged.

Finally in closed circuit applications a hydraulic line restriction is not required. Instead, the charge pump can be used to supply and maintain a minimum pressure of 14 Bar [200 PSI].

Be certain in closed loop applications that the charge pump when used for back pressure on the B port, has sufficient displacement to maintain charge pressure especially in dynamic braking or overrunning load conditions.

Important!

Due to potential problems in maintaining charge pump pressure at port B for uninterrupted back pressure during dynamic braking, Eaton does not recommend the two speed motor where overrunning conditions may exist.

Performance Data

In the high speed mode torque values are approximately one half with twice the speed of the conventional 2000 Series single speed motors.

In the low speed mode torque and speed values are the same as the conventional 2000 Series motors.

2000 Series Two-Speed

Typical Hydraulic Circuit

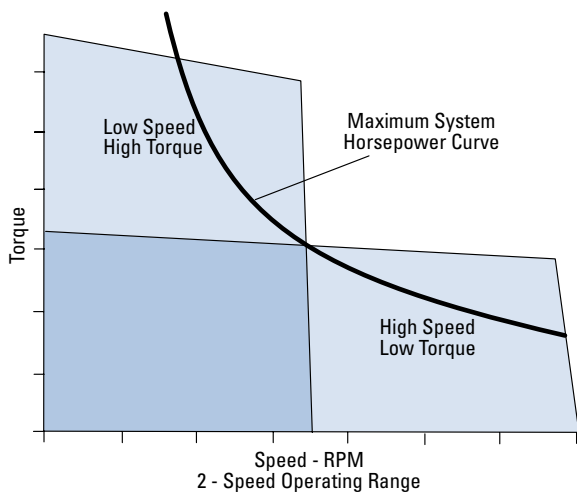
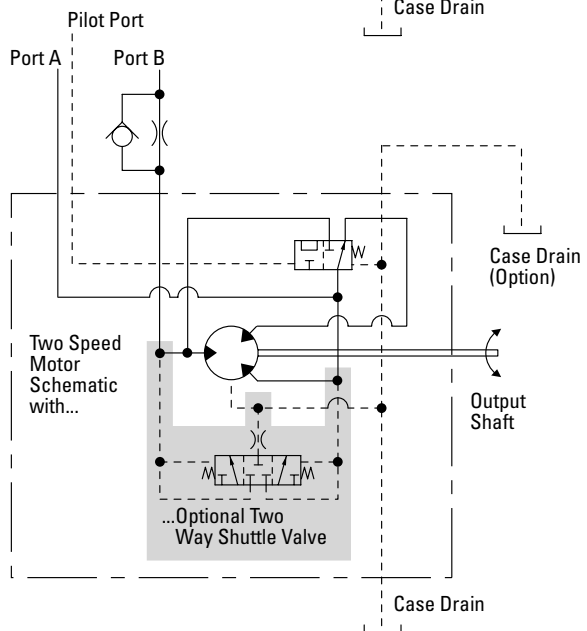
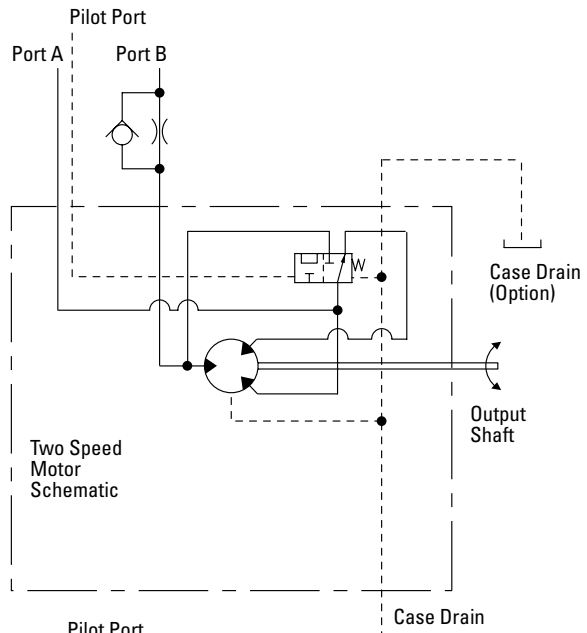
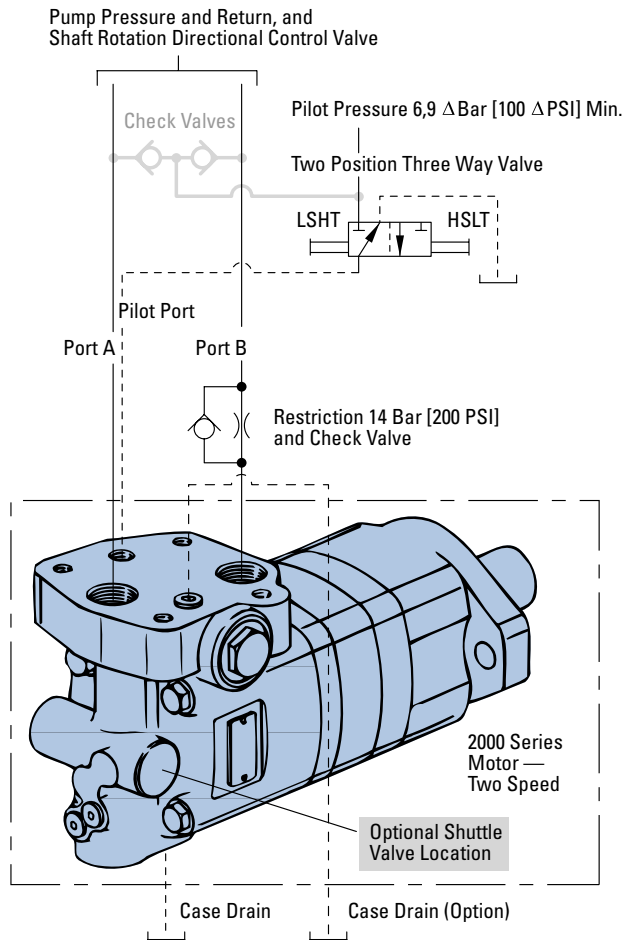

2000 Series Two-Speed Specifications

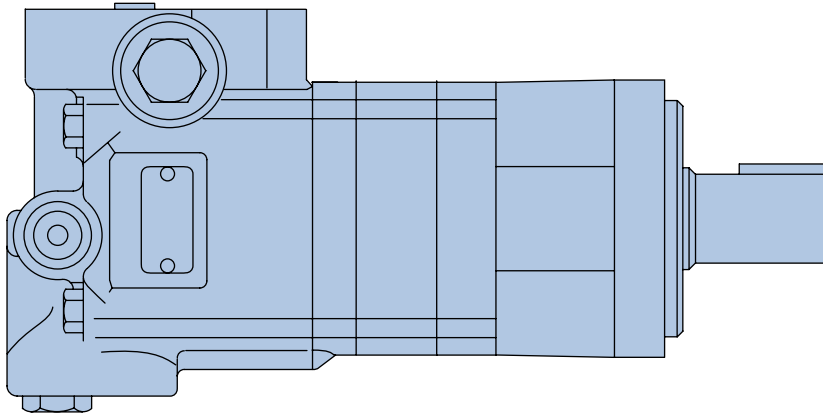

SPECIFICATION DATA — 2000 SERIES TWO-SPEED MOTORS

Displ. cm ³ /r [in ³ /r]	High Speed Mode	40 [2.45]	50 [3.1]	65 [4.0]	80 [4.8]	95 [5.95]	120 [7.45]	155 [9.35]	195 [12.0]	245 [14.9]
	Low Speed Mode	80 [4.9]	100 [6.2]	130 [8.0]	160 [9.6]	195 [11.9]	245 [14.9]	305 [18.7]	395 [24.0]	490 [29.8]
Max. Speed (RPM) @ Continuous Flow	High Speed Mode	1000	1000	990	860	700	560	450	350	230
	Low Speed Mode	500	500	495	430	350	280	225	175	115
Flow l/min [GPM]	High Speed Mode	45 [12]	55 [15]	70 [19]	75 [20]	75 [20]	75 [20]	75 [20]	75 [20]	75 [20]
	Low Speed Mode	45 [12]	55 [15]	70 [19]	75 [20]	75 [20]	75 [20]	75 [20]	75 [20]	75 [20]
Torque* Nm [lb-in]	High Speed Mode									
	Continuous	100 [880]	125 [1115]	165 [1450]	195 [1725]	240 [2150]	300 [2675]	380 [3350]	365 [3225]	448 [3970]
	Intermittent	145 [1300]	185 [1660]	240 [2150]	240 [2150]	300 [2650]	375 [3330]	440 [3900]	445 [3940]	486 [4300]
Torque* Nm [lb-in]	Low Speed Mode									
	Continuous	235 [2065]	295 [2630]	385 [3420]	455 [4040]	540 [4780]	660 [5850]	765 [6750]	775 [6840]	845 [7470]
	Intermittent	345 [3035]	445 [3950]	560 [4970]	570 [5040]	665 [5890]	820 [7250]	885 [7820]	925 [8170]	930 [8225]
Pressure Δ bar [Δ PSI]	Continuous	205 [3000]	205 [3000]	205 [3000]	205 [3000]	205 [3000]	205 [3000]	205 [3000]	155 [2250]	120 [1750]
	Intermittent	310 [4500]	310 [4500]	310 [4500]	260 [3750]	260 [3750]	260 [3750]	260 [3750]	190 [2750]	140 [2000]
Weight kg [lb]	Standard or Wheel Mount	13,8 [30.5]	14,1 [31.0]	14,3 [31.5]	14,5 [32.0]	15,0 [33.0]	15,4 [34.0]	15,9 [35.0]	16,3 [36.0]	16,8 [37.0]
	Bearingless	11,8 [26.0]	12,0 [26.5]	12,2 [27.0]	12,5 [27.5]	12,9 [28.5]	13,4 [29.5]	13,8 [30.5]	14,3 [31.5]	14,7 [32.5]

Maximum Case Pressure: See case pressure seal limitation graph.

*See shaft torque ratings for limitations.

Note:

To assure best motor life, run motor for approximately one hour at 30% of rated pressure before application to full load. Be sure motor is filled with fluid prior to any load applications.

High Speed Mode

(Reduced Motor Displacement)

Low Speed Mode

(Full Motor Displacement)

Maximum Inlet Pressure:

310 bar [4500 PSI]

Do not exceed Δ pressure rating (see chart above).

Maximum Return Pressure:

310 bar [4500 PSI] with case drain line installed.

Do not exceed Δ pressure rating (see chart above).

Δ bar [Δ PSI] :

The true pressure difference between inlet port and outlet port

Continuous Rating:

Motor may be run continuously at these ratings

Intermittent Operation:

10% of every minute

Peak Operation:

1% of every minute

Recommended Fluids:

Premium quality, anti-wear type hydraulic oil with a viscosity of not less than 70 SUS at operating temperature.

Recommended Maximum System Operating Temp.:

82° C [180° F]

Recommended Filtration:

per ISO Cleanliness Code, 4406: 20/18/13

2000 Series Two-Speed

Dimensions

Standard and Wheel

Ports

- 7/8 -14 UNF-2B SAE O-ring Staggered Ports (2)
- 9/16 -18 UNF-2B SAE O-ring Case Drain Port (1)
- 7/16 -20 UNF-2B SAE O-ring Pilot Control Port (1) or
- G 1/2 (BSP) Staggered Ports (2)
- G 1/4 (BSP) Case Drain Port (1)
- G 1/4 (BSP) Pilot Control Port (1)

Standard Rotation Viewed from Shaft End

- Port A Pressurized — CW
- Port B Pressurized — CCW

Two-Speed Standard Motors

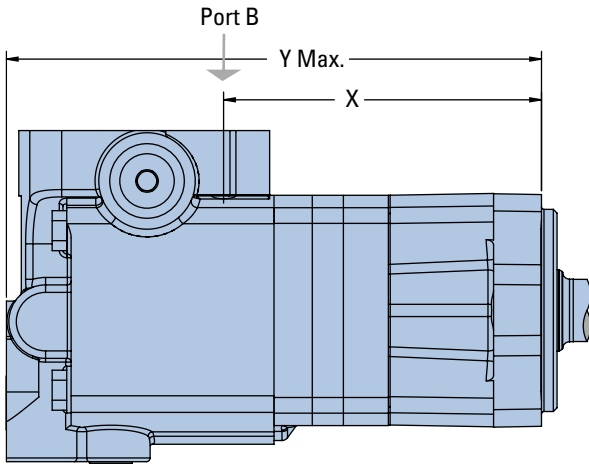

STANDARD MOUNT MOTOR DIMENSIONS

Displacement cm ³ /r [in ³ /r]	X mm [inch]	Y mm [inch]
80 [4.9]	137,4 [5.41]	231,6 [9.12]
100 [6.2]	142,0 [5.59]	236,5 [9.31]
130 [8.0]	148,5 [5.85]	242,9 [9.56]
160 [9.6]	148,5 [5.85]	242,9 [9.56]
195 [11.9]	155,2 [6.11]	249,4 [9.82]
245 [14.9]	164,2 [6.47]	258,6 [10.18]
305 [18.7]	175,7 [6.92]	270,1 [10.63]
395 [24.0]	191,5 [7.54]	286,1 [11.26]
490 [29.8]	209,0 [8.23]	303,3 [11.94]

Two-Speed Wheel Motors

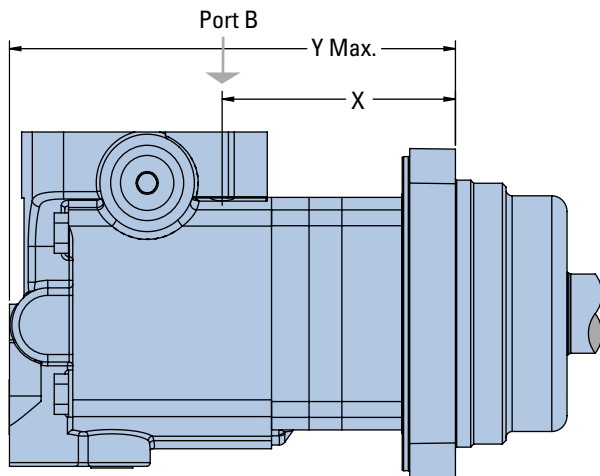

WHEEL MOUNT MOTOR DIMENSIONS

Displacement cm ³ /r [in ³ /r]	X mm [inch]	Y mm [inch]
80 [4.9]	97,2 [3.83]	191,5 [7.54]
100 [6.2]	101,8 [4.01]	196,4 [7.73]
130 [8.0]	108,3 [4.27]	202,7 [7.98]
160 [9.6]	108,3 [4.27]	202,7 [7.98]
195 [11.9]	115,0 [4.53]	209,3 [8.24]
245 [14.9]	124,2 [4.89]	218,5 [8.60]
305 [18.7]	135,5 [5.34]	229,9 [9.05]
395 [24.0]	151,4 [5.96]	245,9 [9.68]
490 [29.8]	168,9 [6.65]	263,1 [10.36]

2000 Series Two-Speed

Dimensions

Bearingless

Ports

- 7/8 -14 UNF-2B SAE O-ring Staggered Ports (2)
- 9/16 -18 UNF-2B SAE O-ring Case Drain Port (1)
- 7/16 -20 UNF-2B SAE O-ring Pilot Control Port (1) or
- G 1/2 (BSP) Staggered Ports (2)
- G 1/4 (BSP) Case Drain Port (1)
- G 1/4 (BSP) Pilot Control Port (1)

Standard Rotation Viewed from Shaft End

- Port A Pressurized — CW
- Port B Pressurized — CCW

Two-Speed Bearingless Motors

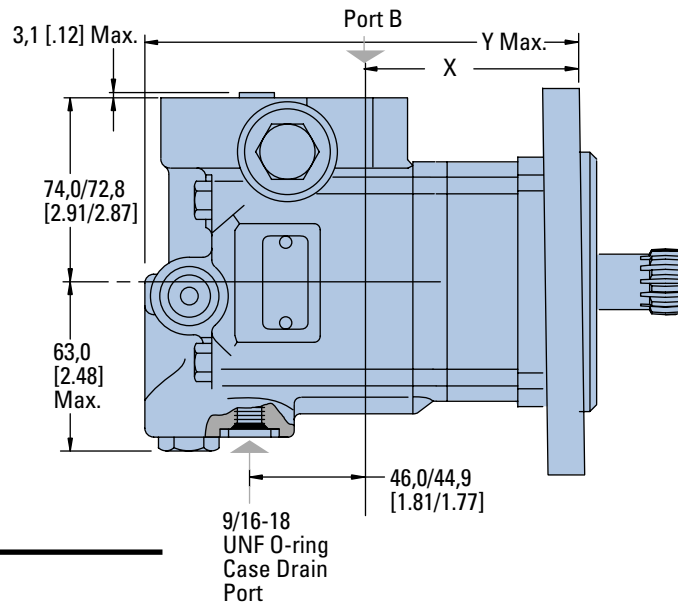
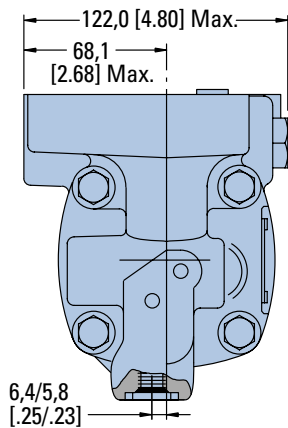
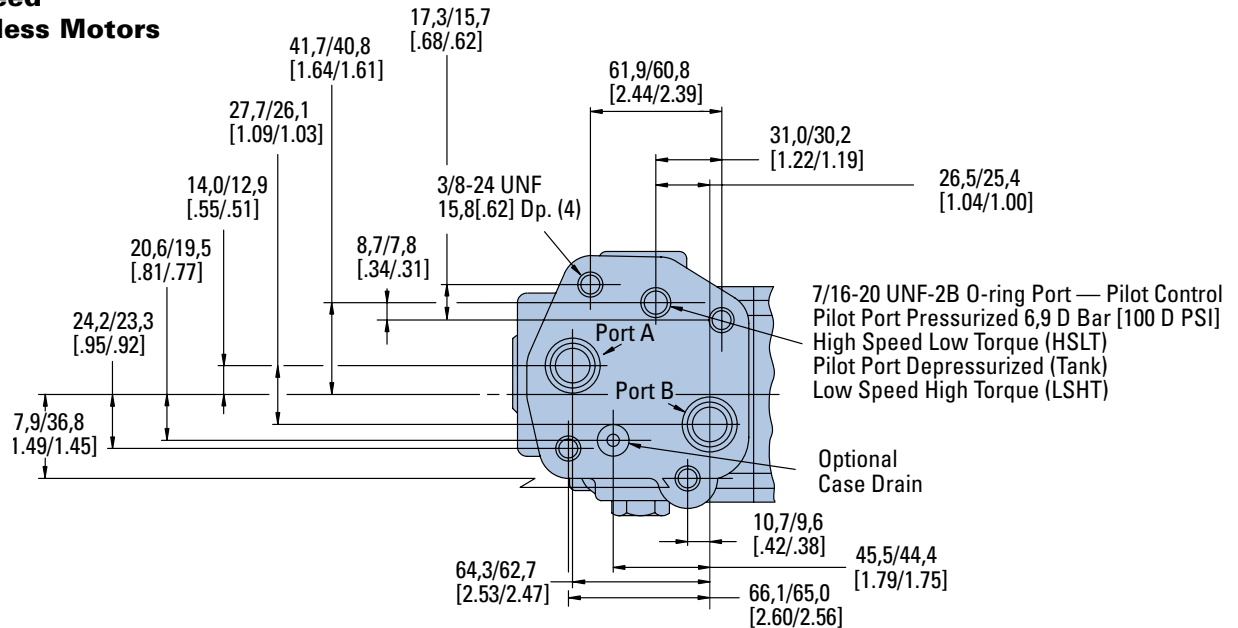

BEARINGLESS MOTOR DIMENSIONS

Displacement cm ³ /r [in ³ /r]	X mm [inch]	Y mm [inch]
80 [4.9]	79,3 [3.13]	174,0 [6.85]
100 [6.2]	84,1 [3.31]	178,9 [7.04]
130 [8.0]	90,7 [3.57]	185,2 [7.29]
160 [9.6]	90,7 [3.57]	185,2 [7.29]
195 [11.9]	97,3 [3.83]	191,8 [7.55]
245 [14.9]	106,4 [4.19]	201,0 [7.91]
305 [18.7]	117,8 [4.64]	212,4 [8.36]
395 [24.0]	133,6 [5.26]	228,4 [8.99]
490 [29.8]	151,1 [5.95]	245,6 [9.67]

2000 Series Two-Speed

Product Numbers

Note:

For 2000 Series Motors with a configuration **Not Shown** in the charts below, contact your Eaton Representative.

Use digit prefix — 104-, 105-, or 106- plus four digit number from charts for complete product number— Example 106-2007.

Orders will not be accepted without three digit prefix.

MOUNTING	SHAFT	PORT SIZE	DISPL. cm ³ /r [in ³ /r] / PRODUCT NUMBER									
			80 [4.9]	100 [6.2]	130 [8.0]	160 [9.6]	195 [11.9]	245 [14.9]	305 [18.7]	395 [24.0]	490 [29.8]	
2 Bolt SAE A Flange	1 Inch Straight	7/8 -14 O-ring Staggered	104-2001	-2002	-2003	-2004	-2005	-2006	-2007	-2008	—	
	1 1/4 Inch Straight	7/8 -14 O-ring Staggered	104-2009	-2010	-2011	-2012	-2013	-2014	-2015	-2016	-2219	
	1 1/4 Inch 14 T Splined	7/8 -14 O-ring Staggered	104-2017	-2018	-2019	-2020	-2021	-2022	-2023	-2024	—	
Wheel Motor	1 1/4 Inch Tapered	7/8 -14 O-ring Staggered	105-2001	-2002	-2003	-2004	-2005	-2006	-2007	-2008	—	
	1 1/4 Inch 14 T Splined	7/8 -14 O-ring Staggered	105-2009	-2010	-2011	-2012	-2013	-2014	-2015	-2016	—	
Bearingless		7/8 -14 O-ring Staggered	106-2001	-2002	-2003	-2004	-2005	-2006	-2007	-2008	—	

106-2007

4000 Compact Series

Highlights

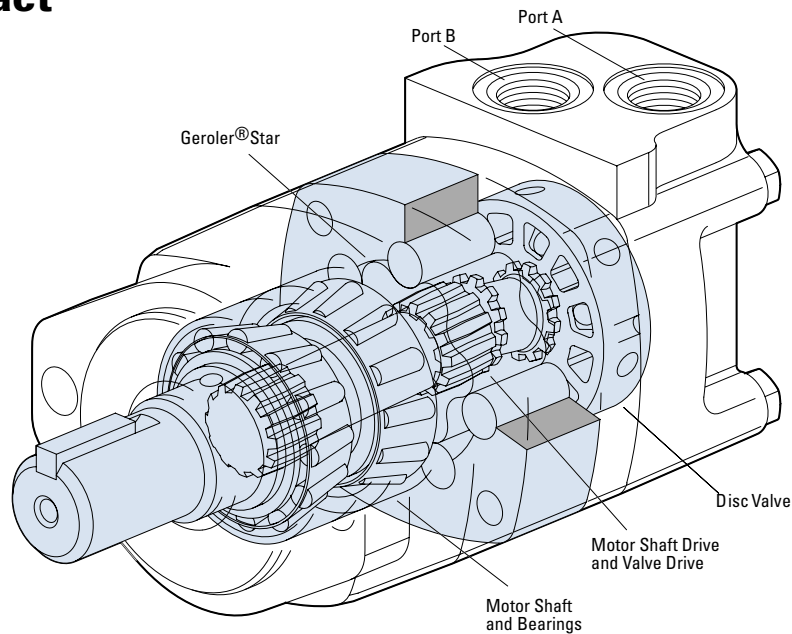

Features

- Shuttle Valve with Back-Pressure Relief Valve
- Speed Sensors
- End Ports.

Benefits

- The bearing capacity of the 4000 Series
- The flow of the 2000 Series

Applications

- Skid Steer Loaders
- Fairway Mowers
- Harvesters
- Vehicles where space may be at a premium.

Description

This new compact edition in a family of disc valve hydraulic motors produces the same amount of torque as the current 4000 Series. Yet, it is housed in an envelope similar to its smaller counterpart, the 2000 Series. The unit's intermittent torque rating is 1220 Nm [10800 lb-in]. A variety of mounting options include two 2 bolt mounts (SAE A, SAE B), and four 4 bolt mounts (magneto, standard and wheel mounts.) For added flexibility, the motor can be specified with either the larger size shafts of the 2000 Series or standard output shaft sizes of the 4000 Series, plus one new 1-1/2 inch straight (the small envelope and optional shaft sizes make this motor ideal for vehicles like skid-steer loaders whose hallmark is high power and productivity in a small frame.)

Specifications

Geroler Element	6 Displacements
Flow l/min [GPM]	75 [20] Continuous**
	115 [30] Intermittent*
Speed RPM	464 Cont.**
	699 Inter.*
Pressure bar [PSI]	200 [3000] Cont.**
	300 [4500] Inter.*
Torque Nm [lb-in]	975 [8627] Cont.**
	1218 [10788] Inter.*

** Continuous—(Cont.) Continuous rating, motor may be run continuously at these ratings.

* Intermittent—(Inter.) Intermittent operation, 10% of every minute.



Lawn and Turf



Skid Steer



Boom Lift



Harvester

4000 Compact Series

Specifications

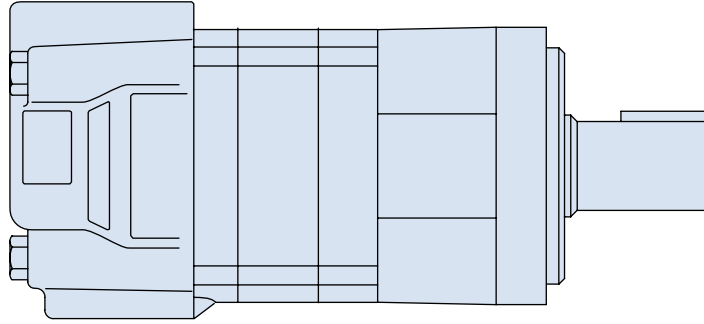

SPECIFICATION DATA — 4000 COMPACT SERIES MOTORS

Displ. cm ³ /r [in ³ /r]		160 [9.8]	200 [12.3]	250 [15.4]	325 [19.8]	405 [24.6]	490 [29.8]
Max. Speed (RPM) @ Flow	Continuous	464	375	300	234	188	155
	Intermittent	699	562	450	351	282	232
Flow l/min [GPM]	Continuous	75 [20]	75 [20]	75 [20]	75 [20]	75 [20]	75 [20]
	Intermittent	115 [30]	115 [30]	115 [30]	115 [30]	115 [30]	115 [30]
Torque* Nm [lb-in]	Continuous	510 [4514]	758 [5715]	734 [6500]	793 [7021]	800 [7079]	975 [8627]
	Intermittent	690 [6108]	840 [7436]	935 [8272]	1053 [9320]	921 [8153]	1218 [10778]
Pressure Δ bar [Δ PSI]	Continuous	225 [3250]	225 [3250]	205 [3000]	170 [2500]	140 [2000]	140 [2000]
	Intermittent	310 [4500]	295 [4250]	260 [3750]	240 [3500]	170 [2500]	171 [2500]
	Peak	310 [4500]	310 [4500]	310 [4500]	310 [4500]	275 [4000]	260 [3750]
Weight kg [lb]	Standard or Wheel Mount	10,4 [23.0]	10,9 [24.0]	11,3 [25.0]	11,8 [26.0]	12,2 [27.0]	12,2 [27.0]
	Bearingless	8,4 [18.5]	8,8 [19.5]	9,3 [20.5]	9,8 [21.5]	10,2 [22.5]	10,2 [22.5]

Maximum Case Pressure: See case pressure seal limitation graph.

*See shaft torque ratings for limitations.

Note:

To assure best motor life, run motor for approximately one hour at 30% of rated pressure before application to full load. Be sure motor is filled with fluid prior to any load applications.

Maximum Inlet Pressure:

310 bar [4500 PSI]
Do not exceed Δ pressure rating (see chart above).

Maximum Return Pressure:

310 bar [4500 PSI] with case drain line installed.
Do not exceed Δ pressure rating (see chart above).

Δ bar [Δ PSI] :

The true pressure difference between inlet port and outlet port

Continuous Rating:

Motor may be run continuously at these ratings

Intermittent Operation:

10% of every minute

Peak Operation:

1% of every minute

Recommended Fluids:

Premium quality, anti-wear type hydraulic oil with a viscosity of not less than 70 SUS at operating temperature.

Recommended Maximum System Operating Temp.:

82° C [180° F]

Recommended Filtration:

per ISO Cleanliness Code, 4406: 20/18/13

4000 Compact Series

Performance Data

160 cm³/r [9.8 in³/r]
 Δ Pressure Bar [PSI]

Motors run with high efficiency in all areas designated with a number for torque and speed. For best motor life select a motor to run with a torque and speed range shown in the light shaded area.

Performance data is typical at 120 SUS. Actual data may vary slightly from unit to unit in production.



	[250] 15	[500] 35	[750] 50	[1000] 70	[1250] 85	[1500] 105	[1750] 120	[2000] 140	[2250] 155	[2500] 170	[2750] 190	[3000] 205	[3250] 225	[3500] 240	[3750] 260	[4000] 275	[4250] 295
[0.25] 0,95	244 28 4	543 61 3															
[0.5] 1,9	274 31 10	554 63 8	854 96 7														
[1] 3,8	274 31 22	593 67 21	899 102 20	1210 137 17	1513 171 17	1816 205 14	2092 236 12	2361 267 10	2621 296 9	2874 325 7	3088 349 6						
[2] 7,5	301 34 40	623 70 39	940 106 38	1261 143 36	1579 178 35	1898 214 33	2197 248 31	2492 282 28	2766 313 24	3033 343 20	3270 369 17	3496 395 14	3761 425 10	4022 454 6			
[4] 15	305 34 87	662 75 85	1004 113 83	1354 153 81	1699 192 79	2046 231 77	2386 270 74	2725 308 72	3049 344 67	3368 381 63	3693 417 59	4016 454 55	4319 488 49	4618 522 44	4828 545 35	5022 567 27	
[6] 23	293 33 133	659 74 131	1003 113 129	1357 153 127	1705 193 124	2056 232 121	2399 271 118	2741 310 114	3074 347 109	3405 385 104	3751 424 99	4098 463 93	4417 499 87	4732 535 80	5023 568 71	5308 600 63	
[8] 30	280 32 181	656 74 179	1002 113 177	1360 154 175	1711 193 172	2066 233 169	2412 273 166	2758 312 162	3100 350 157	3442 389 145	3809 430 139	4180 472 133	4514 510 133	4846 548 127	5218 590 120	5593 632 113	5856 662 104
[10] 38	259 29 228	630 71 225	978 110 223	1348 152 220	1701 192 217	2061 233 213	2408 272 209	2755 311 204	3102 351 199	3450 390 193	3806 430 186	4163 470 179	4500 508 172	4835 546 165	5191 586 157	5547 627 150	5784 653 141
[12] 45	238 27 275	604 68 272	954 108 269	1336 151 266	1692 191 262	2056 232 258	2403 272 253	2752 311 247	3105 351 241	3458 391 235	3802 430 229	4146 468 223	4485 507 214	4824 545 205	5163 583 197	5501 622 189	
[14] 53	210 24 322	577 65 319	923 104 316	1308 148 313	1665 188 308	2034 229 304	2385 269 298	2739 310 293	3092 349 286	3447 390 279	3796 429 272	4144 468 265	4487 507 256	4830 546 247			
[16] 61	182 21 370	550 62 367	893 101 363	1280 145 360	1638 185 356	2012 227 351	2367 267 345	2727 308 339	3080 348 332	3436 388 324	3789 428 317	4143 468 309	4489 507 301	4836 546 292			
[18] 68	143 16 417	514 58 414	853 96 410	1247 141 406	1601 181 401	1973 223 397	2329 263 390	2692 304 383	3045 344 375	3401 384 366	3756 424 358	4114 465 350					
[20] 76	105 12 464	478 54 461	814 92 457	1213 137 453	1564 177 448	1935 219 442	2291 259 435	2658 300 428	3010 340 418	3366 380 409	3724 421 400	4085 462 390					
[22] 83		433 49 508	762 86 504	1167 132 500	1518 172 495	1893 214 489	2252 254 482	2623 296 474	2973 336 465	3328 376 456	3682 416 446	4040 456 436					
[24] 91		387 44 556	711 80 552	1121 127 548	1472 166 542	1851 209 537	2212 250 529	2589 292 521	2937 332 513	3291 372 504	3641 411 493	3995 451 483					
[25] 95		363 41 580	683 77 576	1095 124 572	1445 163 566	1824 206 560	2184 247 552	2561 289 544	2910 329 535	3266 369 526							
[30] 114		244 28 699	546 62 695	967 109 692	1308 148 685	1689 191 678	2045 231 669	2421 274 660	2777 314 648	3144 355 637							

[2777] } Torque [lb-in]
 314 } Nm
 648 } Speed RPM





4000 Compact Series

Performance Data

200 cm³/r [12.3 in³/r]
 Δ Pressure Bar [PSI]

Motors run with high efficiency in all areas designated with a number for torque and speed. For best motor life select a motor to run with a torque and speed range shown in the light shaded area.

Performance data is typical at 120 SUS. Actual data may vary slightly from unit to unit in production.

-  Continuous
-  Intermittent
-  Peak
-  No Operation

	[250]	[500]	[750]	[1000]	[1250]	[1500]	[1750]	[2000]	[2250]	[2500]	[2750]	[3000]	[3250]	[3500]	[3750]	[4000]	[4250]
	15	35	50	70	85	105	120	140	155	170	190	205	225	240	260	275	295
[0.25]	115	504															
0.95	13	57															
[0.5]	268	584	963	1274													
1.9	30	66	109	144													
[1]	306	721	1104	1516	1913	2243	2397	2772									
3.8	35	81	125	171	216	253	271	313									
[2]	402	841	1218	1647	2107	2478	2826	3238	3954	4451	4755	5127	5407	5569	5855		
7.5	45	95	138	186	238	280	319	366	447	503	537	579	611	629	662		
[4]	403	896	1361	1780	2247	2649	3068	3513	3947	4367	4710	5125	5509	5880	6249	6547	6753
15	46	101	154	201	254	299	347	397	446	493	532	579	622	664	706	740	763
[6]	385	863	1354	1785	2260	2657	3087	3547	3965	4389	4793	5218	5610	6015	6408	6754	7436
23	44	98	153	202	255	300	349	401	448	496	542	590	634	680	724	763	840
[8]	368	831	1347	1790	2273	2665	3106	3581	3982		4876	5311	5712	6151	6567	6961	7334
30	42	94	152	202	257	301	351	405	450	498	551	600	645	695	742	786	829
[10]	353	822	1319	1774	2212	2642	3086	3556	3974	4410	4839	5297	5715	6147	6563		
38	40	93	149	200	250	299	349	402	449	498	547	598	646	695	742		
[12]	339	813	1291	1758	2151	2620	3067	3530	3965	4408	4802	5283	5718	6144	6568		
45	38	92	146	199	243	296	346	399	448	498	543	597	646	694	742		
[14]	282	762	1237	1693	2121	2601	2968	3504	3953	4368	4832	5261	5690				
53	32	86	140	191	240	294	335	396	447	493	546	594	643				
[16]	224	712	1183	1629	2091	2581	2870	3477	3940	4328	4861	5240	5661				
61	25	80	134	184	236	292	324	393	445	489	549	592	640				
[18]	200	667	1148	1619	2053	2520	2899	3442	3906	4337	4819	5245	5644				
68	23	75	130	183	232	285	328	389	441	490	544	593	638				
[20]	176	623	1112	1609	2014	2458	2929	3407	3872	4347	4777	5250	5627				
76	20	70	126	182	228	278	331	385	437	491	540	593	636				
[22]	565	1053	1530	1934	2387	2868	3347	3804	4254	4698							
83	64	119	173	219	270	324	378	430	481	531							
[24]	507	994	1450	1855	2316	2806	3287	3737	4162	4618							
91	57	112	164	210	262	317	371	422	470	522							
[25]	465	950	1411	1820	2276	2768	3233	3688	4116	4493							
95	53	107	159	206	257	313	365	417	465	508							
[30]	259	726	1214	1645	2072	2577	2961	3443	3889	3866							
114	29	82	137	186	234	291	335	389	439	437							
		562	563	559	555	556	550	545	536	527	521						

[2072] } Torque [lb-in]
 234 } Nm
 556 } Speed RPM





4000 Compact Series

Performance Data

250 cm³/r [15.4 in³/r]
 Δ Pressure Bar [PSI]

Motors run with high efficiency in all areas designated with a number for torque and speed. For best motor life select a motor to run with a torque and speed range shown in the light shaded area.

Performance data is typical at 120 SUS. Actual data may vary slightly from unit to unit in production.

	Continuous
	Intermittent
	Peak
	No Operation

	[250] 15	[500] 35	[750] 50	[1000] 70	[1250] 85	[1500] 105	[1750] 120	[2000] 140	[2250] 155	[2500] 170	[2750] 190	[3000] 205	[3250] 225	[3500] 240	[3750] 260
[0.5]	384 43 6	833 94 5													
1.9															
[1]	438 49 14	904 102 14	1403 158 13	1887 213 12	2359 267 11	2798 316 9	3221 364 8	3657 413 7	3822 432 4	4326 489 3					
3.8															
[2]	492 56 28	1054 119 27	1563 177 26	2081 235 25	2623 296 24	3160 357 23	3717 420 21	4147 469 17	4585 518 16	5070 573 13	5470 618 9	5721 646 7	5962 674 5		
7.5															
[4]	603 68 58	1183 134 56	1771 200 55	2275 257 54	2817 318 52	3364 380 50	3895 440 47	4495 508 44	5005 565 42	5496 621 38	5982 676 35	6500 734 32	7054 797 28	7519 850 24	7941 897 17
15															
[6]	587 66 23	1159 131 88	1741 197 86	2329 263 82	2815 318 80	3369 381 77	3951 446 74	4483 506 71	5021 567 67	5555 628 63	6068 686 59	6557 741 55	7131 806 50	7641 863 45	8107 916 38
23															
[8]	571 65 118	1135 128 116	1710 193 114	2384 269 112	2813 318 110	3375 381 107	4008 453 103	4471 505 100	5038 569 96	5613 634 92	6154 695 87	6614 747 83	7209 815 78	7763 877 73	8272 935 67
30															
[10]	552 62 148	1138 129 146	1671 189 144	2304 260 142	2804 317 139	3361 380 136	3950 446 131	4452 503 127	5006 566 123	5587 631 119	6123 692 113	6612 747 109	7201 814 102		
38															
[12]	532 60 178	1140 129 177	1631 184 175	2224 251 173	2796 316 170	3347 378 166	3892 440 161	4434 501 157	4974 562 151	5561 628 146	6093 688 141	6610 747 136	7193 813 129		
45															
[14]	441 50 209	1072 121 207	1600 181 205	2207 249 202	2754 311 199	3320 375 195	3888 439 190	4433 501 185	4958 560 179	5529 625 174	6066 685 168	6590 745 162			
53															
[16]	349 39 239	1003 113 237	1568 177 235	2190 247 233	2711 306 229	3292 372 225	3884 439 220	4431 501 214	4941 558 208	5496 621 202	6039 682 195	6570 742 189			
61															
[18]	306 35 269	940 106 267	1513 171 265	2114 239 263	2653 300 259	3251 367 255	3830 433 250	4380 495 243	4904 554 236	5446 615 230	5984 676 223	6518 736 214			
68															
[20]	263 30 300	876 99 298	1458 165 296	2038 230 293	2595 293 290	3210 363 285	3777 427 280	4328 489 272	4867 550 265	5395 610 259	5928 670 251	6471 731 241			
76															
[22]		826 93 328	1414 160 326	1991 225 323	2528 286 320	3144 355 315	3709 419 309	4262 482 302	4806 543 295	5354 605 288	5915 668 279				
83															
[24]		776 88 359	1370 155 356	1945 220 354	2462 278 350	3079 348 345	3642 411 339	4196 474 332	4745 536 325	5313 600 317	5901 667 308				
91															
[25]		732 83 374	1322 149 371	1959 221 369	2426 274 365	3026 342 360	3594 406 354	4153 469 347	4696 531 340	5152 582 333					
95															
[30]		509 57 450	1082 122 449	2029 229 445	2246 254 442	2761 312 437	3358 379 430	3939 445 423	4450 503 414	4347 491 413					
114															

[2246] } Torque [lb-in]
 254 } Nm
 442 } Speed RPM





4000 Compact Series

Performance Data

325 cm³/r [19.8 in³/r]
 Δ Pressure Bar [PSI]

Motors run with high efficiency in all areas designated with a number for torque and speed. For best motor life select a motor to run with a torque and speed range shown in the light shaded area.

Performance data is typical at 120 SUS. Actual data may vary slightly from unit to unit in production.

-  Continuous
-  Intermittent
-  Peak
-  No Operation

	[250] 15	[500] 35	[750] 50	[1000] 70	[1250] 85	[1500] 105	[1750] 120	[2000] 140	[2250] 155	[2500] 170	[2750] 190	[3000] 205	[3250] 225	[350] 240
[0.5] 1.9	536 61 5	1152 130 4												
[1] 3.8	555 63 11	1220 138 10	1900 215 10	2559 289 9	3222 364 9	3862 436 8	4522 511 7	5061 572 5	5580 630 3	6106 690 3				
[2] 7.5	643 73 22	1349 152 21	2025 229 20	2712 306 19	3378 382 19	4051 458 17	4696 531 15	5335 603 13	5889 665 10	6366 719 5	6876 777 3			
[4] 15	679 77 45	1420 160 44	2140 242 43	2852 322 42	3557 402 40	4259 481 38	4947 559 36	5628 636 33	6300 712 30	6960 786 26	7596 858 23	8201 927 19	8767 991 14	932 105 11
[6] 23	654 74 68	1400 158 67	2132 241 66	2859 323 64	3575 404 62	4281 484 59	4977 562 56	5668 640 53	6346 717 49	7021 793 44	7678 868 40	8244 931 38	8792 993 35	
[8] 30	629 71 92	1379 156 90	2125 240 89	2866 324 87	3592 406 85	4304 486 82	5007 566 79	5707 645 75	6392 722 71	7082 800 66	7760 877 61	8400 949 56		
[10] 38	587 66 115	1337 151 114	2082 235 112	2827 319 110	3556 402 107	4272 483 103	4976 562 100	5672 641 94	6362 719 90	7053 797 85				
[12] 45	546 62 139	1295 146 137	2040 230 136	2787 315 134	3520 398 130	4240 479 125	4944 559 121	5638 637 115	6332 715 110	7023 794 105				
[14] 53	489 55 162	1238 140 161	1984 224 159	2729 308 157	3467 392 153	4193 474 148	4903 554 143	5600 633 136	6293 711 131					
[16] 61	431 49 186	1182 134 185	1929 218 183	2671 302 181	3415 386 177	4145 468 171	4861 549 165	5562 628 159	6254 707 153					
[18] 68	360 41 210	1110 125 208	1856 210 206	2600 294 204	3343 378 200	4073 460 195	4794 542 189	5499 621 183						
[20] 76	288 33 234	1038 117 232	1784 202 230	2529 286 228	3271 370 224	4001 452 220	4726 534 214	5436 614 207						
[22] 83		958 108 256	1706 193 254	2451 277 251	3194 361 248	3926 444 243	4650 525 237	5360 606 229						
[24] 91		878 99 279	1628 184 277	2373 268 275	3116 352 271	3850 435 266	4574 517 260	5285 597 252						
[25] 95		826 93 291	1576 178 289	2320 262 287	3063 346 283	3798 429 277	4523 511 271							
[30] 114		566 64 351	1314 148 349	2056 232 346	2799 316 342	3536 399 337	4268 482 332							





[2799]
316 } Torque [lb-in]
342 } Nm
Speed RPM

4000 Compact Series

Performance Data

Motors run with high efficiency in all areas designated with a number for torque and speed. For best motor life select a motor to run with a torque and speed range shown in the light shaded area.

Performance data is typical at 120 SUS. Actual data may vary slightly from unit to unit in production.

-  Continuous
-  Intermittent
-  Peak
-  No Operation

395 cm³/r [24.0 in³/r]

Δ Pressure Bar [PSI]

	[250] 15	[500] 35	[750] 50	[1000] 70	[1250] 85	[1500] 105	[1750] 120	[2000] 140	[2250] 155	[2500] 170
[0.5]	719	1458								
1.9	81	165								
	3	2								
[1]	777	1631	2423	3148	3690					
3.8	88	184	274	356	417					
	8	7	5	4	3					
[2]	853	1812	2596	3375	4179	4845	5375	5841	6501	
7.5	96	205	293	381	472	547	607	660	735	
	17	15	14	12	11	9	8	3	2	
[4]	878	1859	2687	3667	4554	5388	6232	7004	7660	8153
15	99	210	304	414	515	609	704	791	865	921
	35	34	32	30	28	25	23	19	16	11
[6]	882	1836	2716	3680	4577	5388	6269	7079	7856	
23	100	207	307	416	517	609	708	800	888	
	54	52	51	48	46	42	39	35	31	
[8]	885	1813	2746	3694	4600	5388	6307	7153	8052	
30	100	205	310	417	520	609	713	808	910	
	73	72	70	68	65	62	58	55	50	
[10]	810	1736	2693	3639	4540	5390	6310	7151	7994	
38	92	196	304	411	513	609	713	808	903	
	92	90	89	86	84	80	75	71	67	
[12]	735	1660	2640	3584	4480	5391	6314	7149		
45	83	188	298	405	506	609	713	808		
	111	110	108	106	103	98	93	88		
[14]	661	1622	2560	3512	4412	5330	6242	7059		
53	75	183	289	397	498	602	705	798		
	130	128	127	124	121	117	112	108		
[16]	587	1585	2480	3440	4343	5268	6170			
61	66	179	280	389	491	595	697			
	149	147	146	143	141	137	131			
[18]	492	1472	2379	3333	4270	5190	6084			
68	56	166	269	377	482	586	687			
	168	167	165	162	160	156	150			
[20]	397	1359	2279	3226	4197	5112	5999			
76	45	153	257	365	474	578	678			
	188	186	184	182	179	175	170			
[22]		1264	2194	3124	4093	5008	5904			
83		143	248	353	462	566	667			
		205	203	201	198	193	188			
[24]		1169	2110	3023	3989	4904	5810			
91		132	238	342	451	554	656			
		224	222	220	216	212	207			
[25]		1106	2049	2961	3929	4851	5766			
95		125	231	335	444	548	651			
		233	232	229	226	222	217			
[30]		790	1744	2655	3634	4587	5543			
114		89	197	300	411	518	626			
		282	280	277	274	270	266			

[2655] } Torque [lb-in]
300 } Nm
227 } Speed RPM

4000 Compact Series





Performance Data

490 cm³/r [29.8 in³/r]

Δ Pressure Bar [PSI]

Motors run with high efficiency in all areas designated with a number for torque and speed. For best motor life select a motor to run with a torque and speed range shown in the light shaded area.

Performance data is typical at 120 SUS. Actual data may vary slightly from unit to unit in production.

	Continuous
	Intermittent
	Peak
	No Operation

Flow LPM [GPM]

	[250] 15	[500] 35	[750] 50	[1000] 70	[1250] 85	[1500] 105	[1750] 120	[2000] 140	[2250] 155	[2500] 170
[0.5] 1,9	375 42 3	1669 189 3								
[1] 3,8	525 59 7	1762 199 7	2945 333 6	3965 448 6	5099 576 6	5926 670 5	6715 759 4	7503 848 3		
[2] 7,5	639 72 14	2108 238 14	3287 371 13	4169 471 13	5416 612 11	6570 742 11	7188 812 9	8295 937 6	8959 1012 5	
[4] 15	981 111 30	2201 249 29	3333 377 29	4574 517 28	5558 628 27	6634 750 26	7694 869 24	8627 975 21	9567 1081 18	10399 1175 13
[6] 23	1049 119 45	2218 251 45	3332 376 44	4584 518 43	5604 633 42	6670 754 40	7711 871 38	8713 984 35	9698 1096 31	10588 1196 26
[8] 30	1118 126 61	2236 253 60	3331 376 60	4593 519 59	5650 638 58	6705 758 56	7727 873 54	8798 994 51	9828 1110 48	10778 1218 44
[10] 38	1060 120 76	2230 252 76	3304 373 75	4503 509 75	5607 633 73	6693 756 72	7721 872 69	8836 998 66		
[12] 45	1003 113 92	2223 251 91	3276 370 91	4413 499 90	5564 629 89	6680 755 88	7715 872 85	8874 1003 82		
[14] 53	858 97 108	2127 240 107	3136 354 107	4320 488 106	5496 621 105	6542 739 103	7653 865 100			
[16] 61	713 81 124	2030 229 123	2997 339 122	4226 477 122	5428 613 121	6403 723 119	7590 858 115			
[18] 68	631 71 139	1907 215 139	2935 332 138	4133 467 137	5330 602 136	6339 716 134	7431 840 130			
[20] 76	548 62 155	1784 202 154	2872 325 153	4041 457 153	5232 591 152	6275 709 150	7362 832 148			
[22] 83		1669 189 170	2704 306 169	3928 444 169	5048 570 168	6124 692 166	7208 814 164			
[24] 91		1553 175 186	2536 287 185	3816 431 185	4864 550 184	5972 675 182	7055 797 179			
[25] 95		1469 166 193	2475 280 193	3737 422 193	4810 543 192	5909 668 190	6959 786 187			
[30] 114		1047 118 232	2172 245 232	3341 378 232	4538 513 231	5592 632 229	6482 732 227			

[3341]
378 } Torque [lb-in]
232 } Nm
Speed RPM

4000 Compact Series

Dimensions

Ports

- 7/8 -14 UNF-2B SAE O-ring Staggered Ports (2)
- 7/16 -20 UNF-2B SAE O-ring Case Drain Port (1) or
- 1 1/16 -12 UN-2B SAE O-ring Ports (Positioned 180° Apart) (2)
- 7/16 -20 UNF-2B SAE O-ring Case Drain Port (1) or
- 7/8 -14 UNF-2B SAE O-ring End Ports (2)
- 7/16 -20 UNF-2B SAE O-ring Case Drain Port (1) or
- G 1/2 (BSP) Staggered Ports (2)
- G 1/4 (BSP) Case Drain Port (1) or
- Manifold Mount
- 7/16 -20 UNF-2B SAE O-ring Case Drain Port (1)

Standard Rotation Viewed from Shaft End

- Port A Pressurized — CW
- Port B Pressurized — CCW

Standard Mount

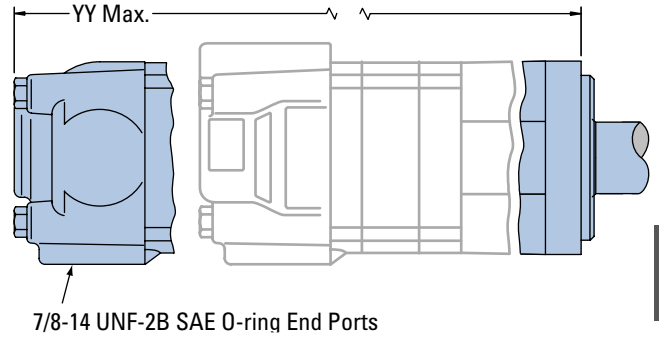
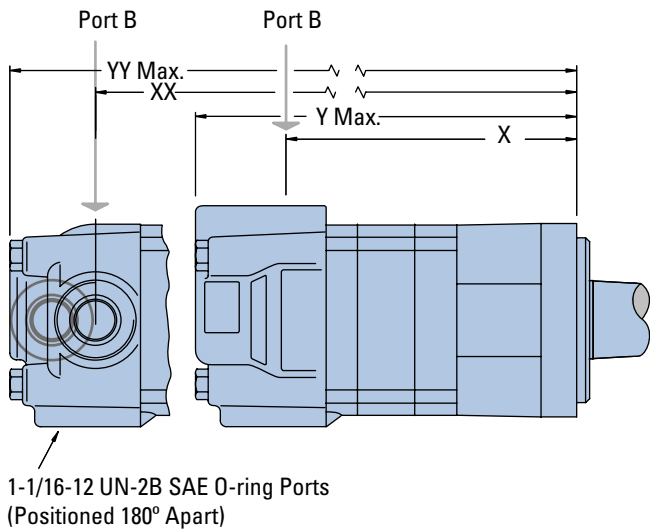

STANDARD MOUNT MOTOR DIMENSIONS

Displacement	X	Y	XX	YY
cm ³ /r [in ³ /r]	mm [inch]	mm [inch]	mm [inch]	mm [inch]
160 [9.8]	154,7 [6.09]	201,9 [7.95]	157,0 [6.18]	203,3 [8.00]
200 [12.3]	163,8 [6.45]	211,1 [8.31]	166,1 [6.54]	212,3 [8.36]
250 [15.4]	175,3 [6.90]	222,5 [8.76]	177,5 [6.99]	223,8 [8.81]
325 [19.8]	191,0 [7.52]	238,5 [9.39]	193,3 [7.61]	239,8 [9.44]
405 [24.6]	208,5 [8.21]	255,8 [10.07]	210,8 [8.30]	257,0 [10.12]
490 [29.8]	208,5 [8.21]	255,8 [10.07]	210,8 [8.30]	257,0 [10.12]

4000 Compact Series

Dimensions

Ports

- 7/8 -14 UNF-2B SAE O-ring Staggered Ports (2)
- 7/16 -20 UNF-2B SAE O-ring Case Drain Port (1) or
- 1 1/16 -12 UN-2B SAE O-ring Ports (Positioned 180° Apart) (2)
- 7/16 -20 UNF-2B SAE O-ring Case Drain Port (1) or
- 7/8 -14 UNF-2B SAE O-ring End Ports (2)
- 7/16 -20 UNF-2B SAE O-ring Case Drain Port (1) or
- G 1/2 (BSP) Staggered Ports (2)
- G 1/4 (BSP) Case Drain Port (1) or
- Manifold Mount
- 7/16 -20 UNF-2B SAE O-ring Case Drain Port (1)

Standard Rotation Viewed from Shaft End

- Port A Pressurized — CW
- Port B Pressurized — CCW

Wheel Mount

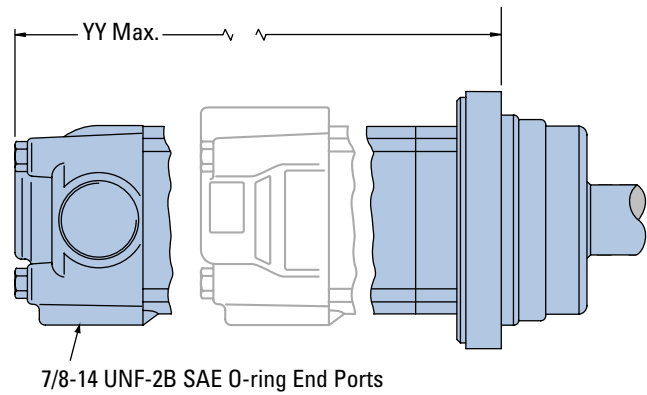
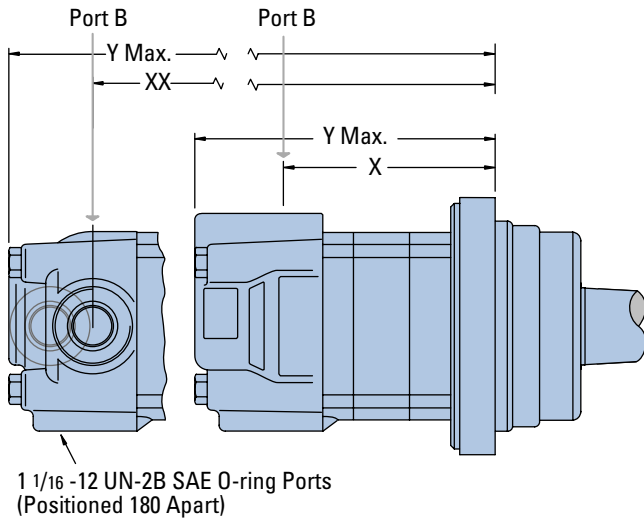

WHEEL MOUNT MOTOR DIMENSIONS

Displacement	X	Y	XX	YY
cm ³ /r [in ³ /r]	mm [inch]	mm [inch]	mm [inch]	mm [inch]
160 [9.8]	114,6 [4.51]	161,8 [6.37]	114,6 [4.51]	161,8 [6.37]
200 [12.3]	123,7 [4.87]	170,9 [6.73]	123,7 [4.87]	170,9 [6.73]
250 [15.4]	135,1 [5.32]	182,4 [7.18]	135,1 [5.32]	182,4 [7.18]
325 [19.8]	150,9 [5.94]	198,4 [7.81]	150,9 [5.94]	198,4 [7.81]
405 [24.6]	168,4 [6.63]	215,6 [8.49]	168,4 [6.63]	215,6 [8.49]
490 [29.8]	168,4 [6.63]	215,6 [8.49]	168,4 [6.63]	215,6 [8.49]

4000 Compact Series

Dimensions

Bearingless

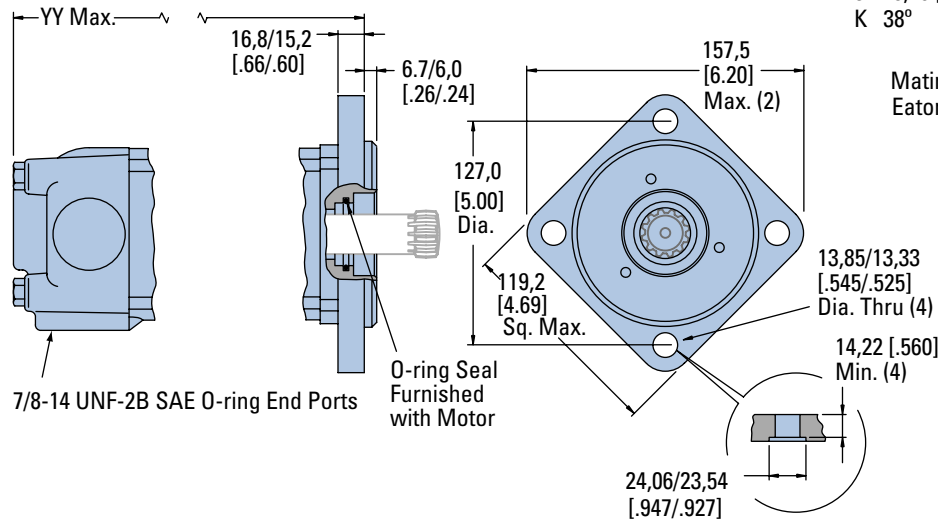
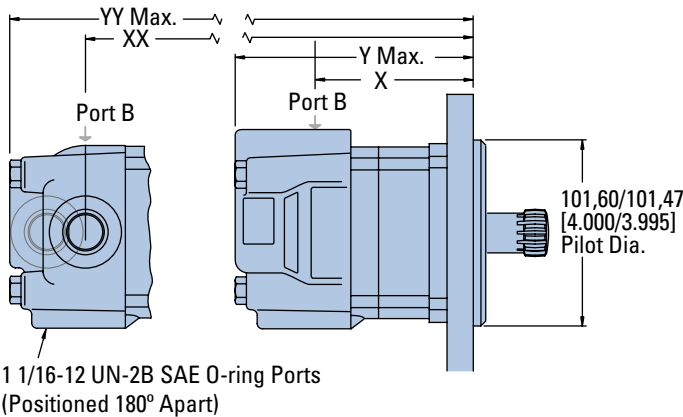

Ports

- 7/8 -14 UNF-2B SAE O-ring Staggered Ports (2)
- 7/16 -20 UNF-2B SAE O-ring Case Drain Port (1) or
- 1 1/16 -12 UN-2B SAE O-ring Ports (Positioned 180° Apart) (2)
- 7/16 -20 UNF-2B SAE O-ring Case Drain Port (1) or
- 7/8 -14 UNF-2B SAE O-ring End Ports (2)
- 7/16 -20 UNF-2B SAE O-ring Case Drain Port (1) or
- G 1/2 (BSP) Staggered Ports (2)
- G 1/4 (BSP) Case Drain Port (1) or
- Manifold Mount
- 7/16 -20 UNF-2B SAE O-ring Case Drain Port (1)

Standard Rotation Viewed from Shaft End

- Port A Pressurized — CW
- Port B Pressurized — CCW

For 4000 bearingless motor application information, contact your Eaton representative (mating coupling blanks available from Eaton Hydraulics).

Note:

After machining blank, part must be hardened per Eaton specification.

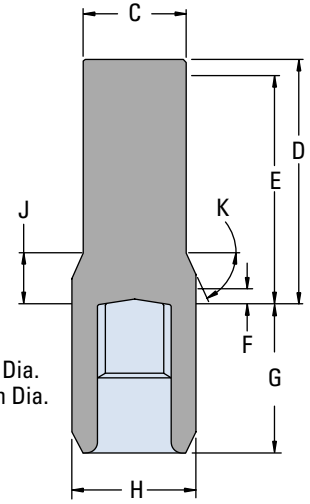

- C 47,2 [1.86] Dia.
- D 112,5 [4.43] Max.
- E 107,4 [4.23] Full Form Dia.
- F 7,4 [.29] Min. Full Form Dia.
- G 68,8 [2.71] Max.
- H 56,9 [2.24] Dia.
- J 18,29 [.720]
- K 38°

BEARINGLESS MOTOR DIMENSIONS

Displacement	X	Y	XX	YY
cm ³ /r [in ³ /r]	mm [inch]	mm [inch]	mm [inch]	mm [inch]
160 [9.8]	96,8 [3.81]	144,3 [5.68]	99,1 [3.90]	145,5 [5.73]
200 [12.3]	105,7 [4.16]	153,4 [6.04]	108,0 [4.25]	154,7 [6.09]
250 [15.4]	117,1 [4.61]	164,8 [6.49]	119,4 [4.70]	166,1 [6.54]
325 [19.8]	133,1 [5.24]	180,8 [7.12]	135,4 [5.33]	182,1 [7.17]
405 [24.6]	150,4 [5.92]	198,1 [7.80]	152,7 [6.01]	199,4 [7.85]
490 [29.8]	150,4 [5.92]	198,1 [7.80]	152,7 [6.01]	199,4 [7.85]

4000 Compact Series

Installation Information

Bearingless

- 1 Internal spline in mating part to be per spline data specification. Material to be ASTM A304, 8620H vacuum degassed alloy steel carbonize to a hardness of 59-62 HRC with case depth (to 50HRC) of 0,76 - 1,02 [.030 - .040] dimensions apply after heat treat.
- 2 Mating part to have critical dimensions as shown. Oil holes must be provided and open for proper oil circulation.
- 3 Seal to be furnished with motor for proper oil circulation thru splines.

- 4 Some means of maintaining clearance between shaft and mounting flange must be provided.
- 5 Counterbore designed to adapt to a standard sleeve bearing 50,010 - 50,040 [1.9689 - 1.9700] ID by 60,050 - 60,080 [2.3642 - 2.3653] (Oilite bronze sleeve bearing) Source: Beemer Precision Inc. www.oilite.com, 1-800-836-2340 AAM 50 mm ID - 60 mm OD Length Determined by the Customer.
Stock Bearing Lengths:
35 mm
50 mm
60 mm
70 mm
75 mm

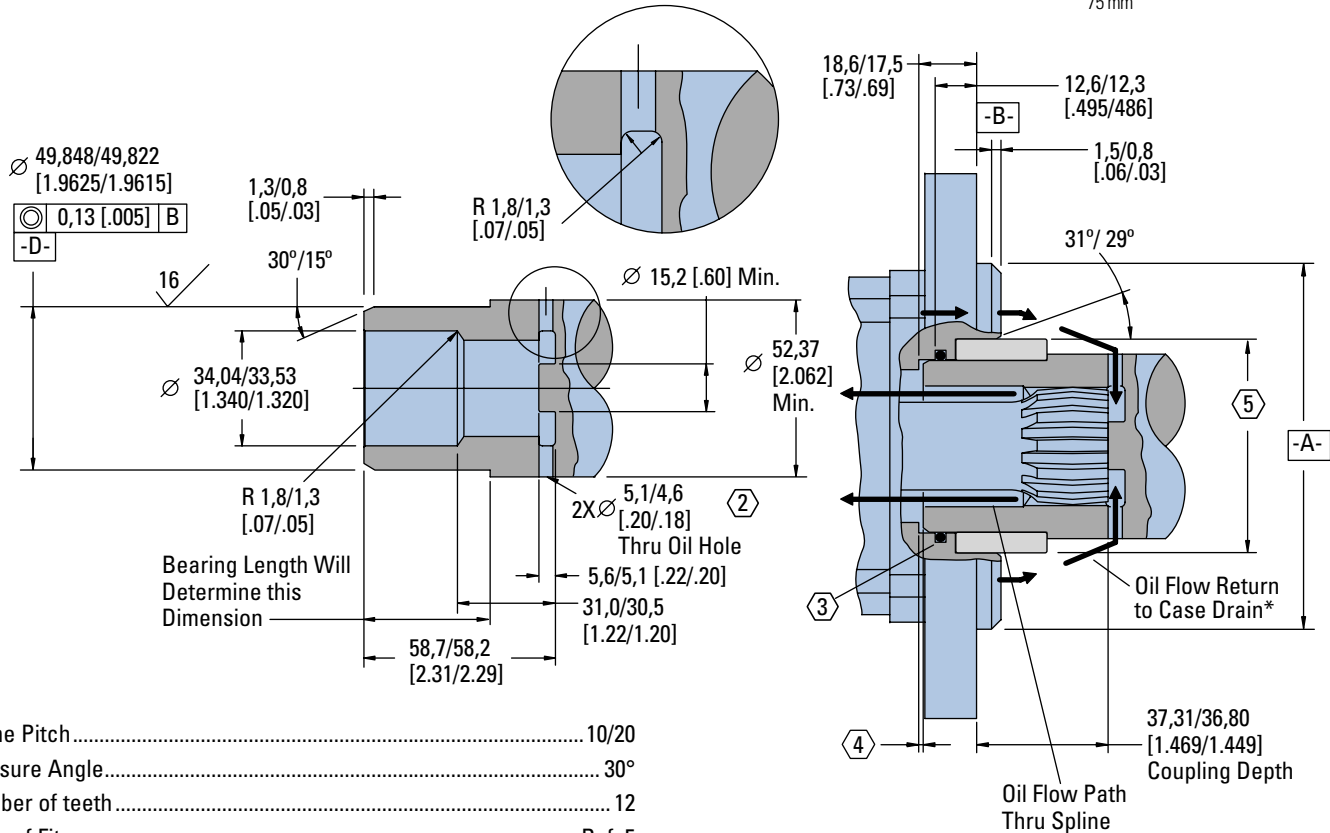

Spline Pitch.....	10/20
Pressure Angle.....	30°
Number of teeth.....	12
Class of Fit.....	Ref. 5
Type of Fit.....	Side
Pitch Diameter.....	Ref. 30,480000 [1.2000000] ∇ 0,20 [.008] \square D
Base Diameter.....	Ref. 26,396455 [1.0392305]
Major Diameter.....	(33,43 [1.316] Max. 33,23 [1.308] Min.)
Minor Diameter.....	28,40 - 25,58 [1.118 - 1.125]
Form Diameter, Min.....	32,59 [1.283]
Fillet Radius.....	0,63 - 0,76 [.025 - .030]
Tip Radius.....	0,26 - 0,51 [.010 - .020]
Finish.....	1,6 (63)
Involute Profile Variation.....	+0,000 -0,025 [+0.0000 -0.0010]
Total Index Variation.....	0,038 [.0015]
Lead Variation.....	0,013 [.0005]
Circular Space Width:	
Maximum Actual.....	5,045 [.1986]
Minimum Effective.....	4,995 [.1951]
Maximum Effective.....	Ref. 5,009 [.1972]
Minimum Actual.....	Ref. 4,986 [.1963]
Dimension Between Two Pins.....	Ref. 22,783 - 22,929 [.8970 - .9027]
Pin Diameter.....	5,334 [.2100] Pins to Have 3,73 [.147]
	Wide Flat for Root Clearance

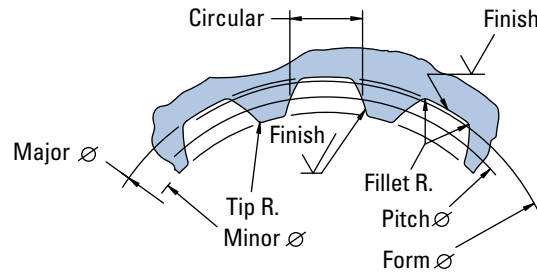

4000 Compact Series

Dimensions

Mounting Options

SAE A — Two Bolt (Standard Motor)

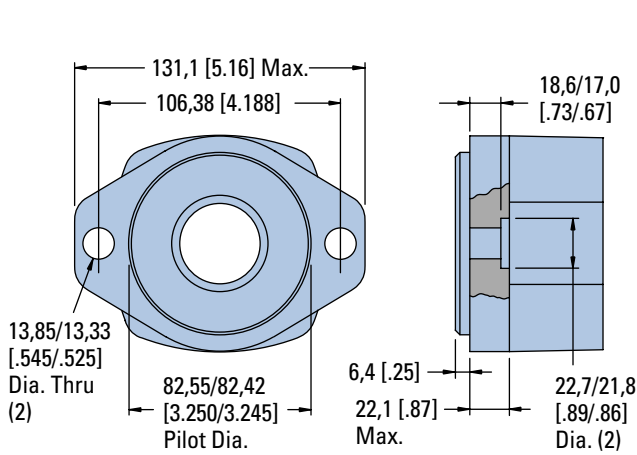

Four Bolt Magneto

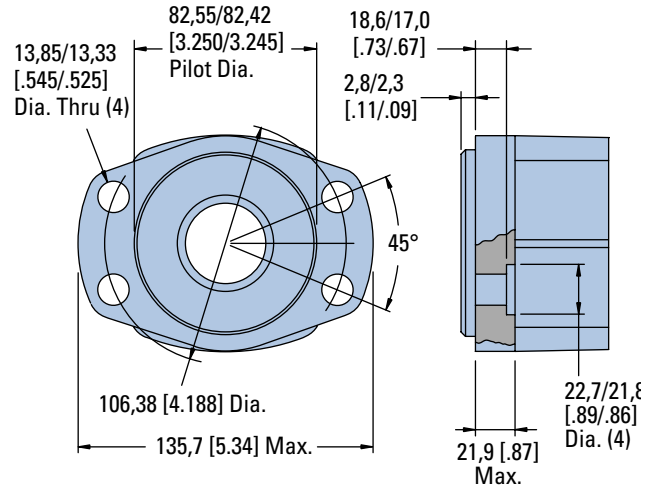

Two Bolt SAE B

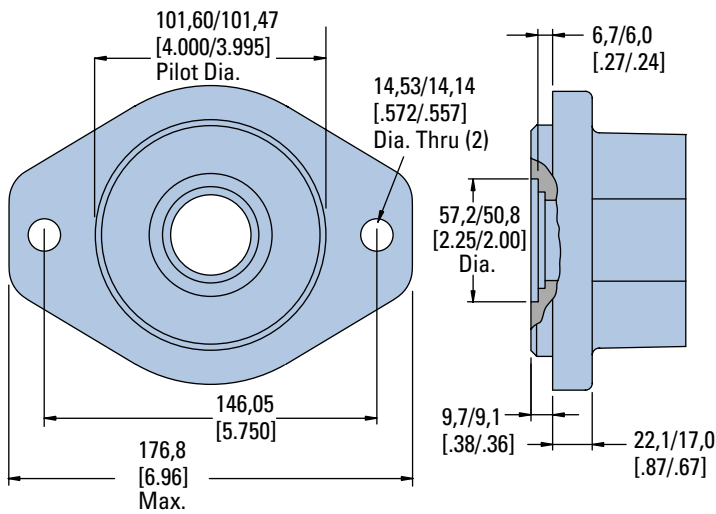

Four Bolt

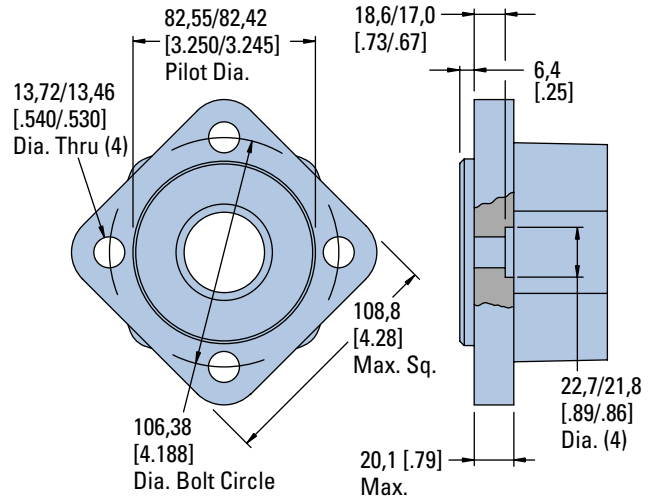

Four Bolt (Wheel Motor)

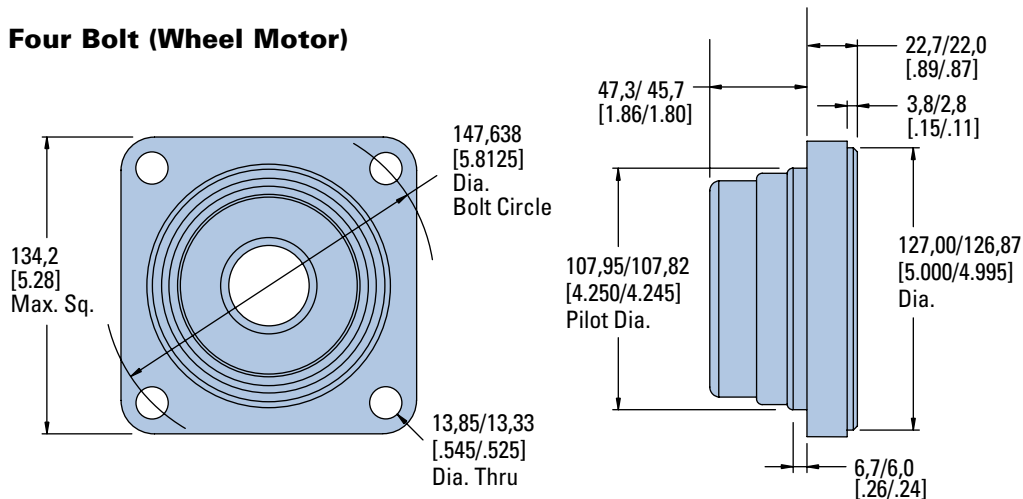

4000 Compact Series

Dimensions

Mounting Options for use with Enhanced Bearings

Standard Flange- Similar to SAE B type

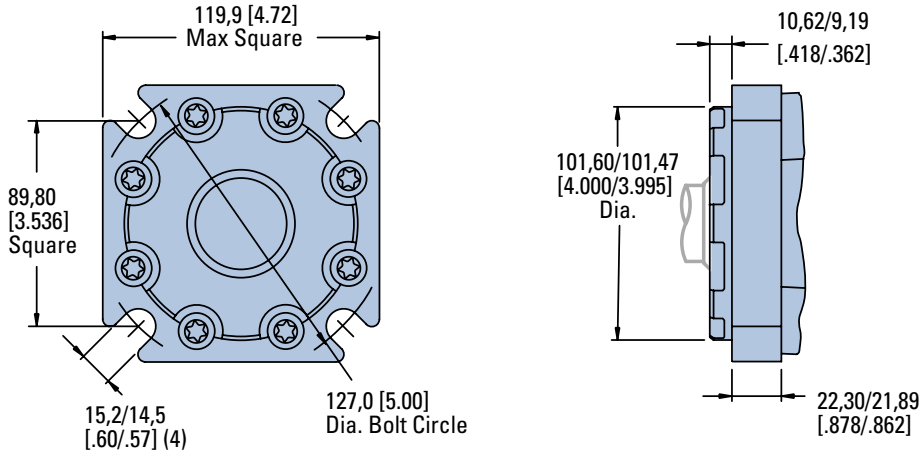

Four Bolt (Wheel Motor)

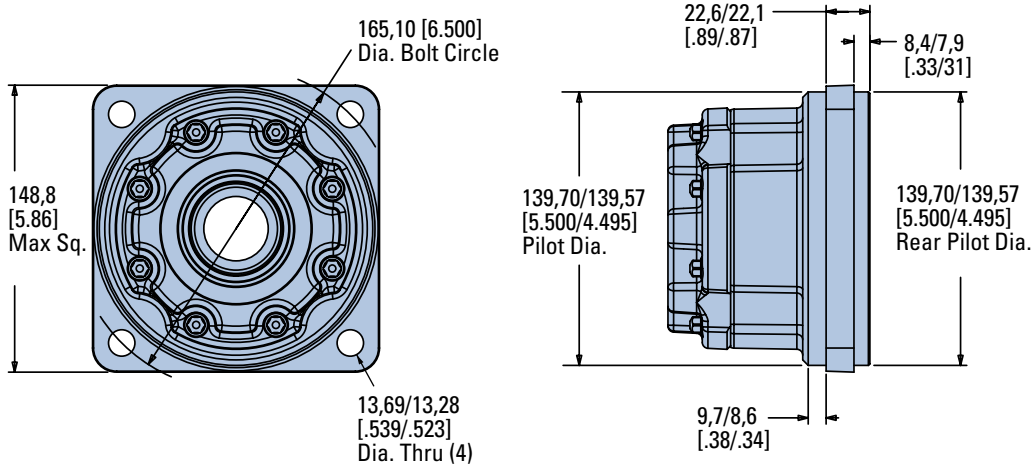

Four Bolt (Wheel Motor- Short)

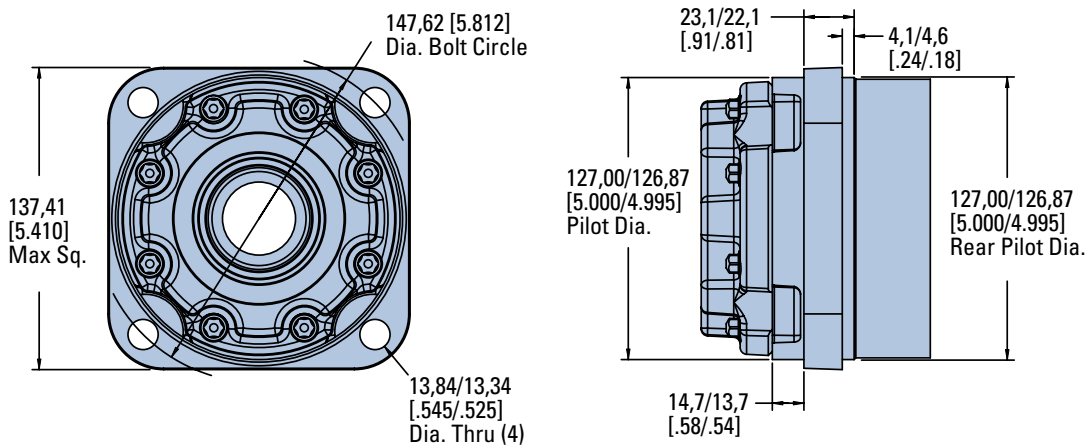

4000 Compact Series

Dimensions

Shafts

1-5/8 Inch Tapered

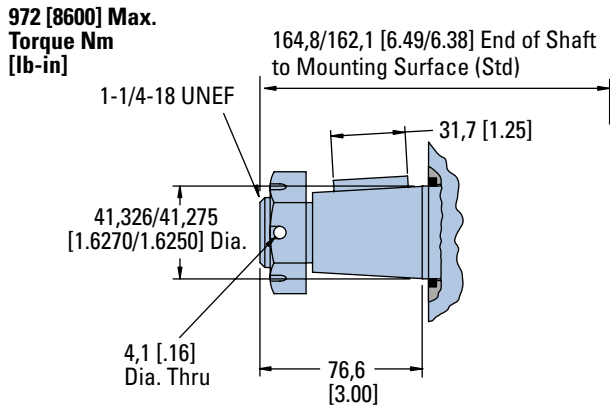

SAE J501 Standard Tapered Shaft
125,00 0,17 Taper per Meter
[1.500 .002 Taper per Foot]

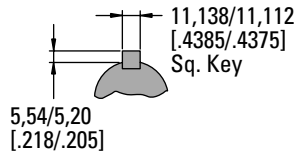

1-1/4 Inch Tapered

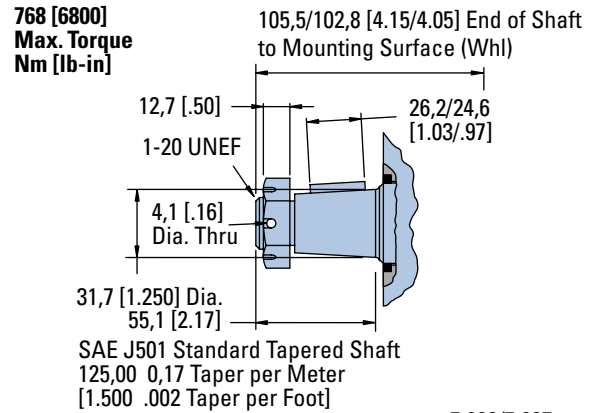

SAE J501 Standard Tapered Shaft
125,00 0,17 Taper per Meter
[1.500 .002 Taper per Foot]

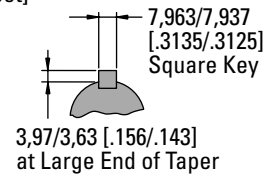

Tapered Shaft Hub Data

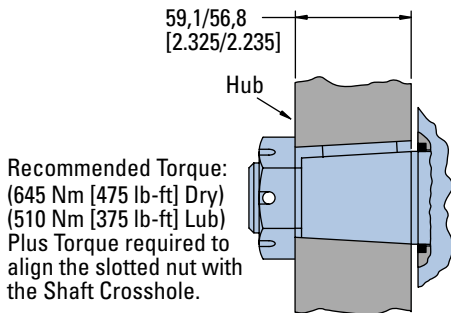

Tapered Shaft Hub Data

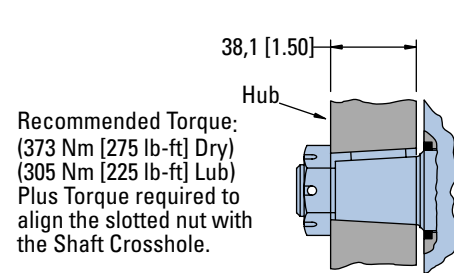

Slotted Hexagon Nut

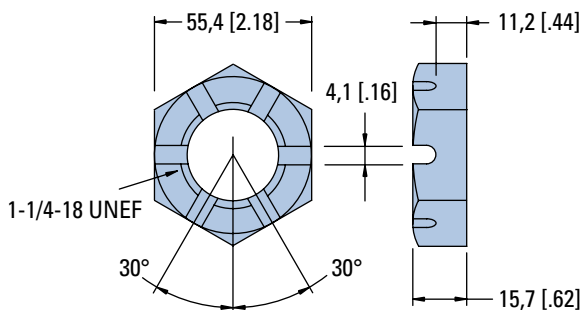

Slotted Hexagon Nut

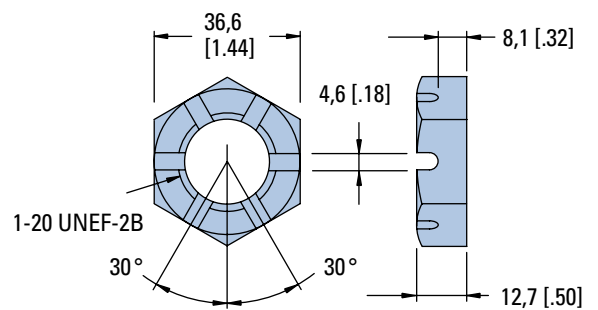

4000 Compact Series

Dimensions

Shafts

1-1/2 Inch Straight

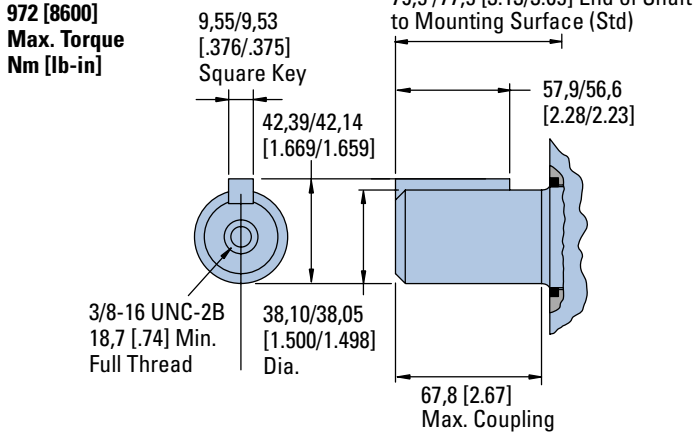

1-1/4 Inch Straight

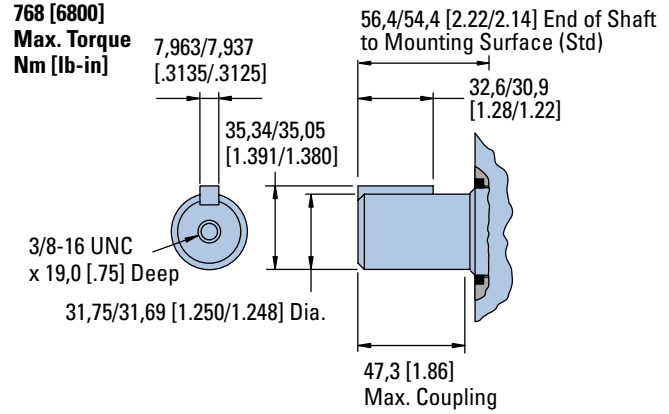

40 mm Straight

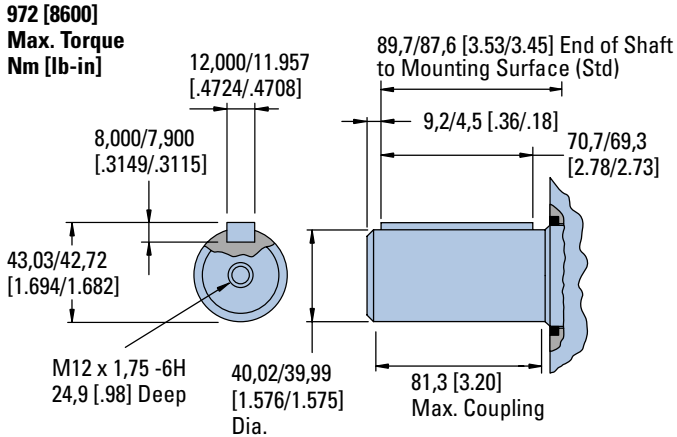

32 mm Straight

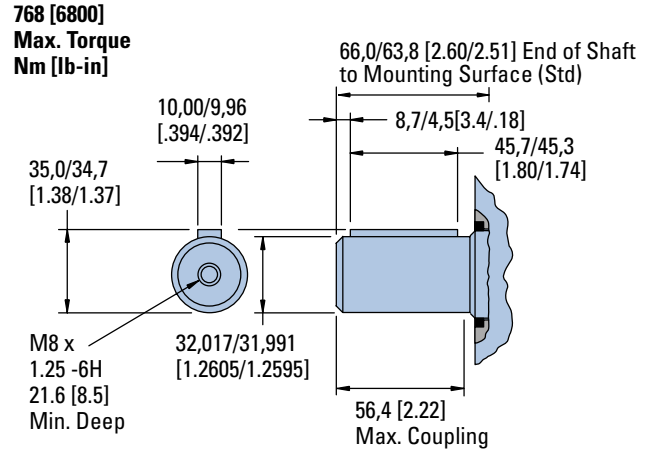

1-1/2 Inch 17 Tooth Straight

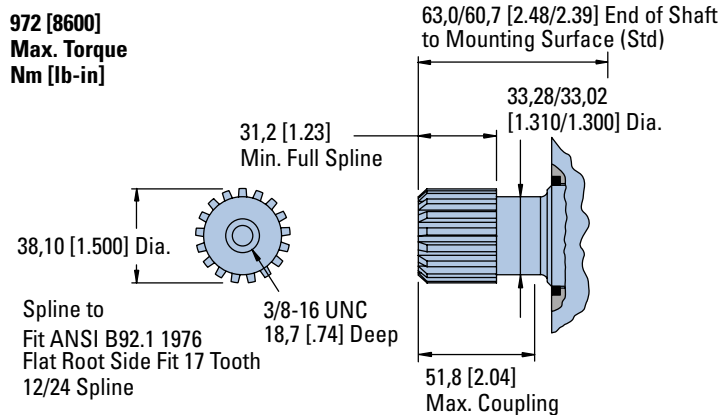

1-1/4 Inch 14 Tooth Splined

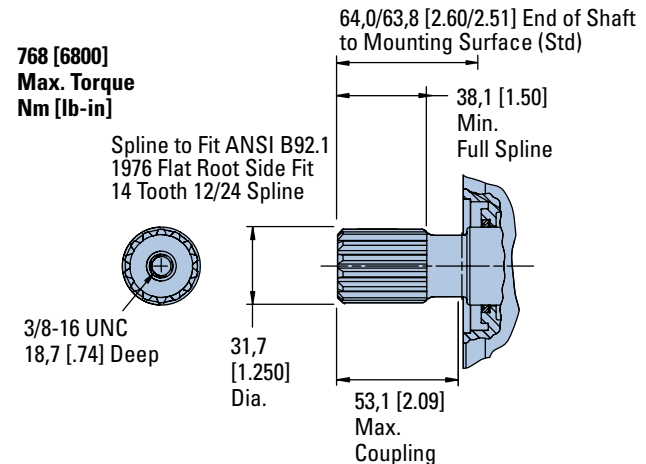

4000 Compact Series

Shaft Side Load Capacity

These curves indicate the radial load capacity on the motor shafts) at various locations with an allowable external thrust load of 454 kg [1000 lb].

Note:

Case pressure will increase the allowable inward thrust load and decrease the allowable outward thrust load. Case pressure will push outward on the shaft at 94 kg/7 Bar [208 lb/100 PSI].

Each curve is based on

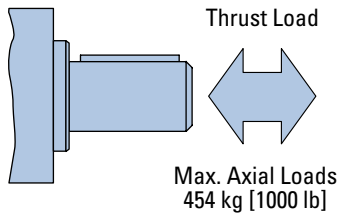

B 10 bearing life (2000 hours of 12,000,000 shaft revolutions at 100 RPM) at rated output torque.

To determine radial load at speeds other than 100 RPM, multiply the load values given on the bearing curve by the factors in the chart below.

RPM	Multiplication Factor
50	1.23
100	1.00
200	0.81
300	0.72
400	0.66
500	0.62
600	0.58
700	0.56
800	0.54

For 3,000,000 shaft revolutions or 500 hours — Increase these shaft loads 52%.

Standard Mount- All shaft options 1-1/4 inch and larger

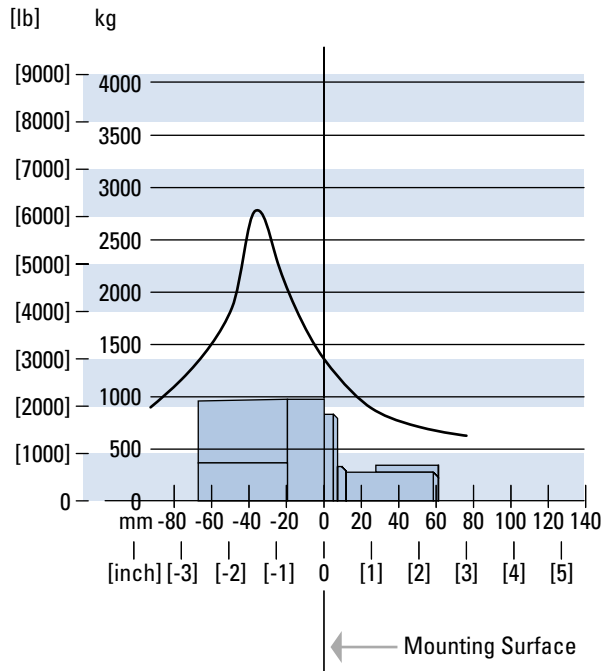

Wheel Mount- All shaft options 1-1/4 inch and larger

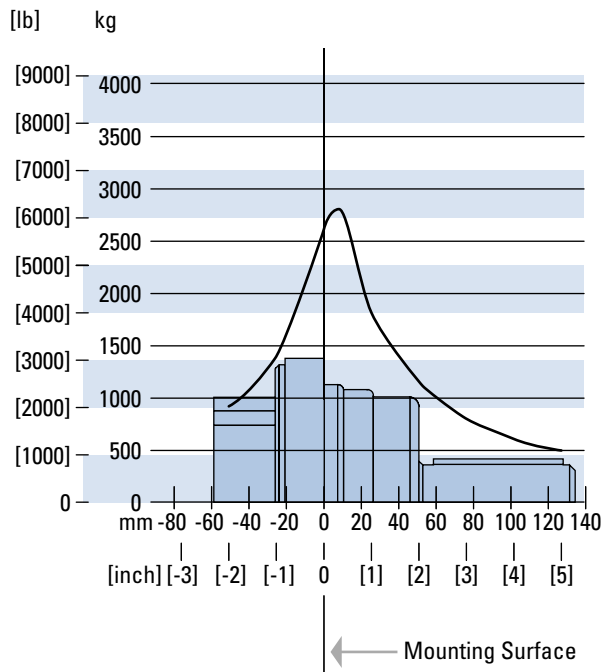

4000 Compact Series

Case Pressure and Case Port

Char-Lynn 4000 Compact Series motors are durable and have long life as long as the recommended case pressure is not exceeded. Allowable case pressure is highest at low shaft speeds. Consequently, motor life will be shortened if case pressure exceeds these ratings (acceptability may vary with application). Determine if an external case drain is required from the case pressure seal limitation charts.

Case Porting Advantage

Contamination Control — flushing the motor case.

Cooler Motor — exiting oil draws motor heat away.

Extend Motor Seal Life — maintain low case pressure with a preset restriction in the case drain line.

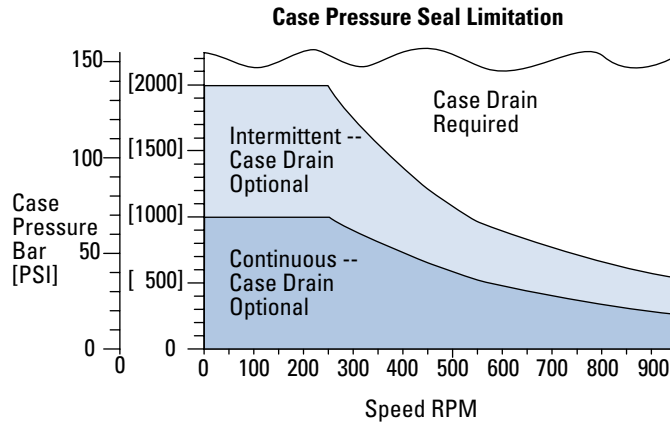

All Shaft options 1-1/4 inch and smaller.

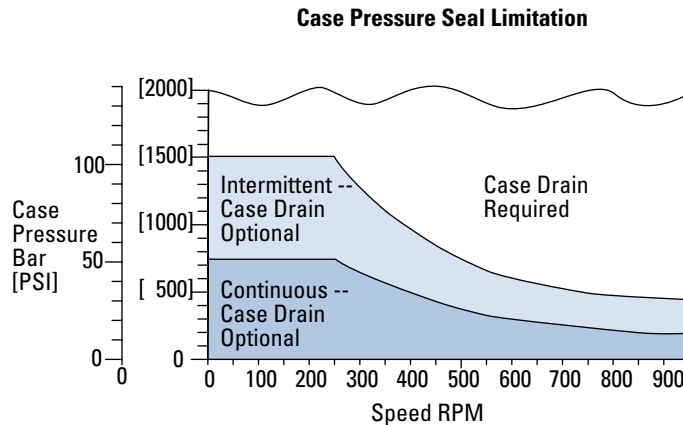

All Shaft options larger than 1-1/4 inch.

4000 Compact Series

Dimensions

Ports

7/8-14 O-ring Ports (2) or G 1/2 (BSP) Ports (2)

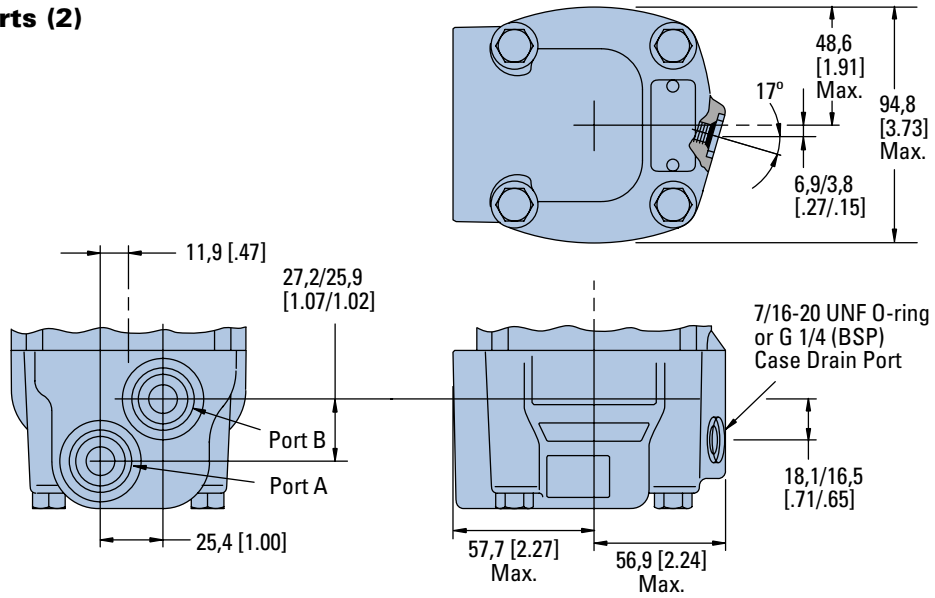

Manifold Mount

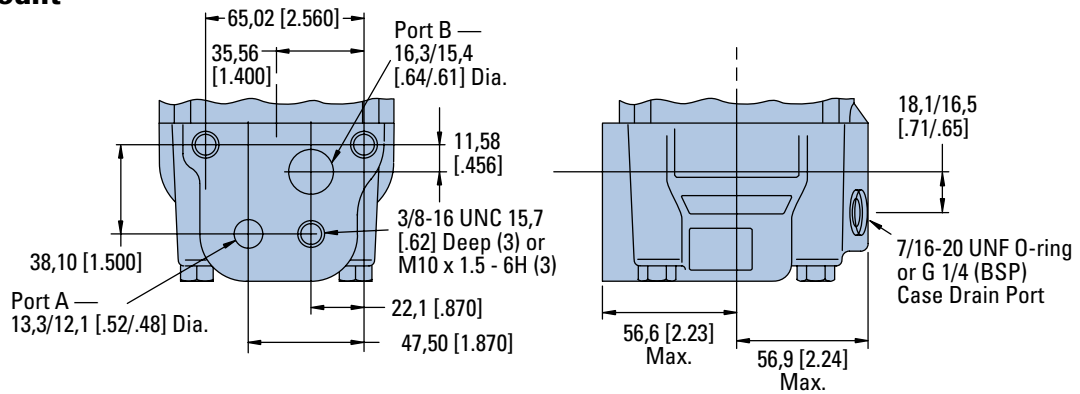

4000 Compact Series

Dimensions

Ports

1-1/16-12 O-ring Ports (2) Positioned 180° Apart

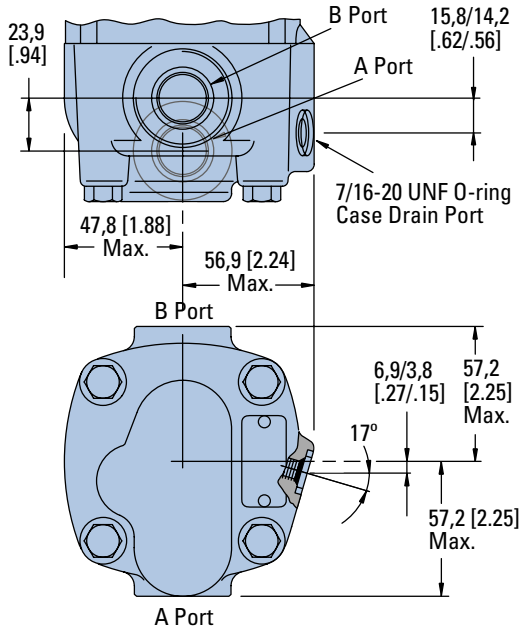

7/8-14 O-ring End Ports (2)

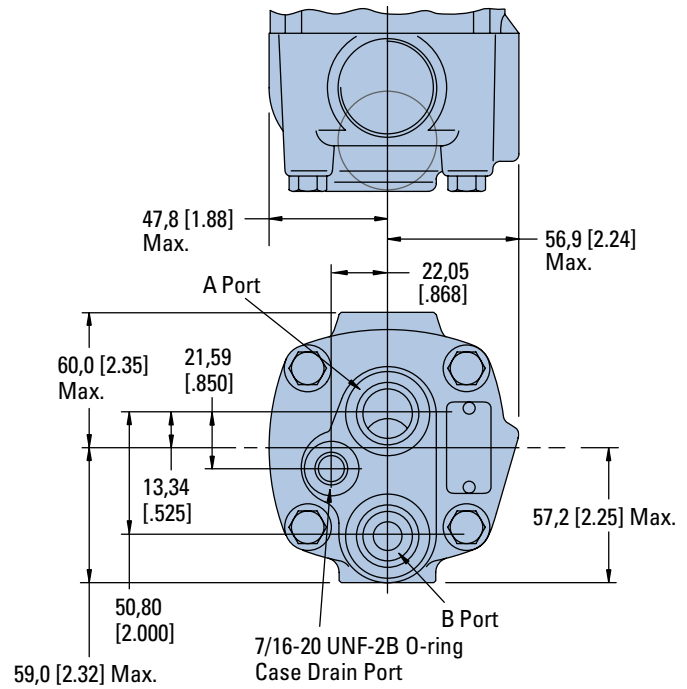

4000 Compact Series

Dimensions

Ports with Shuttle

7/8-14 O-ring Ports (2) or G 1/2 (BSP) Ports (2)

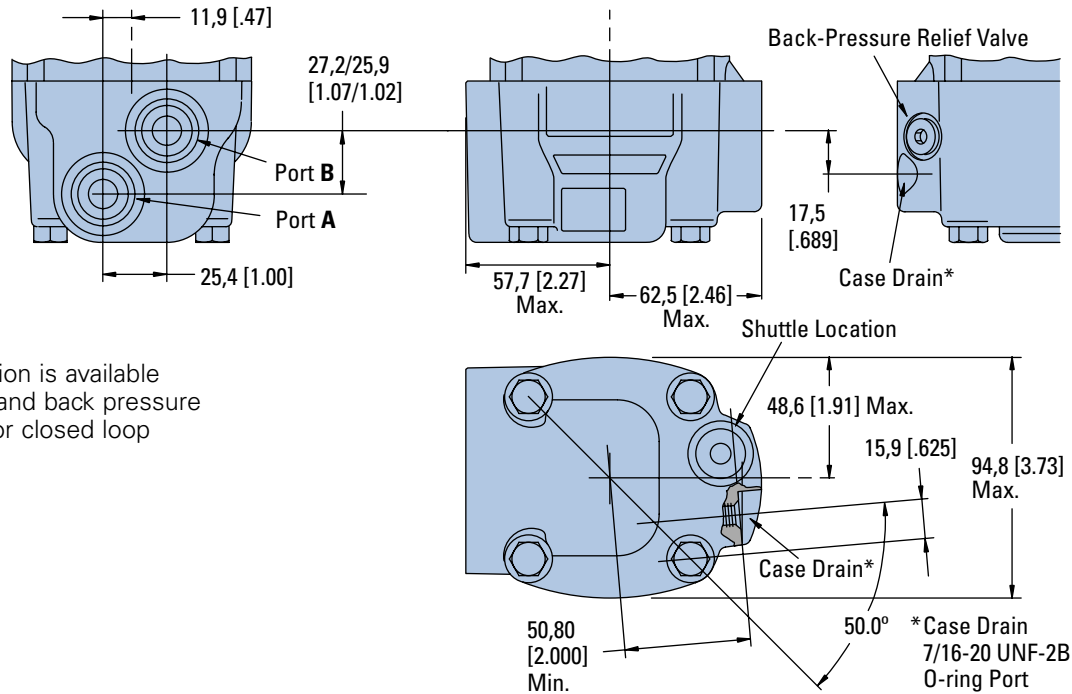

This port option is available with shuttle and back pressure relief valve for closed loop applications.

7/8-14 O-ring End Ports (2)

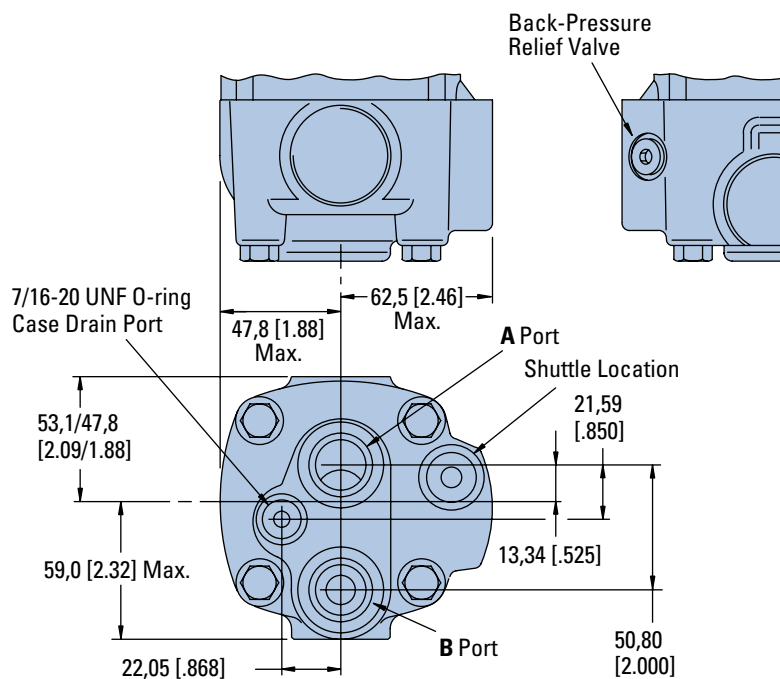

This port option is available with shuttle and back pressure relief valve for closed loop applications.

4000 Compact Series

Model Code

The following 24-digit coding system has been developed to identify all of the configuration options for the 4000 Compact Series motor. Use this model code to specify a motor with the desired features. All 24 digits of the code must be present when ordering. You may want to photocopy the matrix below to ensure that each number is entered in the correct box.

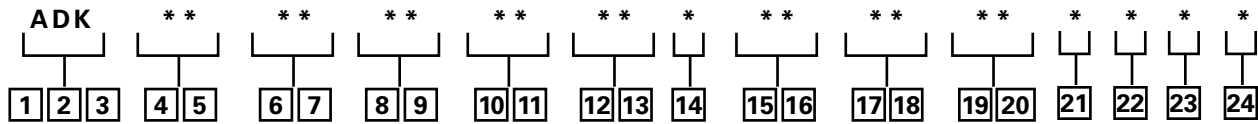

1, 2, 3 Product Series
ADK – 4000 Compact Series Motor

4, 5 Displacement cm³/r [in³/r]

- 10** – 160 [9.8]
- 12** – 200 [12.3]
- 15** – 250 [15.4]
- 20** – 325 [19.8]
- 25** – 405 [24.6]
- 30** – 490 [29.8]

6, 7 Mounting Type

AB – 4 Bolt (Wheel) 108,0 [4.25] Pilot Dia. and 13,59 [.535] Dia. Mounting Holes on 147,6 [5.81] Dia. B.C. 127,0 [5.00] Dia. Rear Mount Pilot

AC – 2 Bolt SAE A (Std.) 82,5 [3.25] Pilot Dia and 13,59 [.535] Dia. Mtg. Holes on 106,4 [4.19] Dia. B.C.

AE – 4 Bolt (Bearingless) 101,6 [4.00] Pilot Dia. and 13,59 [.535] Dia. Mounting Holes on 127,0 [5.00] Dia. B.C.

AF – 2 Bolt SAE B (Std.) 101,6 [4.00] Pilot Dia. and 14,35 [.565] Dia. Mtg. Holes on 146,0 [5.75] Dia. B.C.

AH – 4 Bolt (Standard) 82,5 [3.25] Pilot Dia. and 14,59 [.535] Dia. Mounting Holes on 106,4 [4.19] Dia. B.C.

AJ – 4 Bolt Magneto (Std.) 82,6 [3.25] Pilot Dia. and 13,59 [.535] Dia. Mtg. Holes on 106,4 [4.19] Dia. B.C. 2,79 [.110] Pilot Length

AP – 4 Bolt (wheel compatible for Hayes Brake) 107,9 [4.25] Pilot Dia. and 13,59 [.535] Dia. Mounting Holes on 147,6 [5.81] Dia. B.C. with Turned Down Housing to 88,9 [3.50] Dia.

BB* – 4 Bolt (SAE B) (Standard) 101,6 [4.00] Pilot Dia. and 14,7 [.58] Dia. Mounting Slots on 127,0 [5.00] Dia. B.C.

BE* – 4 Bolt (Wheel) 139,7 [5.50] Front and Rear Pilot Dia. and 13,49 [.531] Dia. Mounting Holes on 165,1 [6.50] Dia. B.C.

BG* – 4 Bolt (Wheel- Short) 127,0 [5.00] Front and Rear Pilot Dia. and 13,59 [.535] Dia. Mounting Holes on 147,62 [5.812] Dia. B.C.

8, 9 Output Shaft

- 00** – None (Bearingless)
- 02** – 1 1/4 inch Dia. Straight with 3/8 -16 Thread in end, 7,938 [.3125] Sq. x 31,75 [1.250] Straight Key
- 03** – 1 1/4 inch Dia. .125 : 1 Tapered Shaft Per SAE J501 with 1-20 UNEF -2A Threaded Shaft end, and slotted Hex Nut, 7,938 [.3125] Sq. x 25,40 [1.000] Straight Key
- 06** – 1 1/4 inch Dia. Splined 14T with 38,1 [1.50] Min. Full Spline Length and 53,1 [2.09] Max. Coupling Length
- 08** – 40 mm Dia. Straight (with Straight Key) M12 x 1,75 - 6H Thread in end
- 10** – 32 mm dia. Straight (with Straight Key) M8 x 1,25 -6H Thread in end, and 56,4 [2.22] Max. Coupling Length
- 11** – 1 1/2 inch Dia. Straight (with Straight Key) 3/8 -16 Thread in end
- 98** – 1 5/8 inch Dia. Tapered with Straight Key and 1 1/4 -18 UNEF Slotted Hex. Nut
- 99** – 1 1/2 inch Dia. Splined 17T with 31,2 [1.23] Min. Full Spline Length

10, 11 Ports

- AA** – 7/8 -14 UNF -2B SAE O-ring (Staggered)
- AB** – 12,70 [.500] and 15,88 [.625] Dia. Ports (Manifold) and 3x 3/8 -16 UNC Port Block Mounting Holes
- AD** – 7/8 -14 UNF -2B SAE O-ring (End Ports)
- AE** – 12,70 [.500] and 15,88 [.625] Dia. Ports (Manifold) and 3 x M10 x 1,5-6H Port Block Mounting Holes

AG – G 1/2 BSP Straight Thread ports (Staggered)

AH – 1 1/16 - 12 UN-2B O-ring ports (Positioned 180° Apart)

12, 13 Case Flow Options

- 00** – None
- 01** – 7/16 -20 UNF -2B SAE O-ring Port (Case Drain)
- 02** – G 1/4 (BSP) Straight Thread Port (Case Drain)
- 14** – Reverse Flow Shuttle Valve with G 1/4 (BSP) Straight Thread Port (Case Drain)

14 Back-Pressure Relief Valve

- 0** – None
- A** – Set at 4,5 bar [65 PSI] (for Manual Pumps)

15, 16 Valve Options

- 00** – None

17, 18 Accessories

- 00** – None
- AA** – Seal Guard
- AF** – M12 Threaded Connector Digital Speed Sensor (Two 30 Pulse per rev. signals in quadrature)
- AG** – M12 Threaded Connector Digital Speed Sensor (One 60 Pulse per rev. speed signal and one directional signal)

19, 20 Special Features (Hardware)

- 00** – None
- 01** – Viton Seals

21 Special Features (Assembly)

- 0** – None
- A** – Flange Rotated 90°
- B** – Reverse Rotation

22 Paint/ Special Packaging

- 0** – No Paint, Individual Box
- A** – Painted Low Gloss Black, Individual Box
- B** – Corrosion Protected

23 Eaton Assigned Code when Applicable

- 0** – Assigned Code

24 Eaton Assigned Design Code

- 0** – Assigned Design Code

* These mounting options are available with shaft options 08, 11, 98 and 99.

4000 Series

Highlights

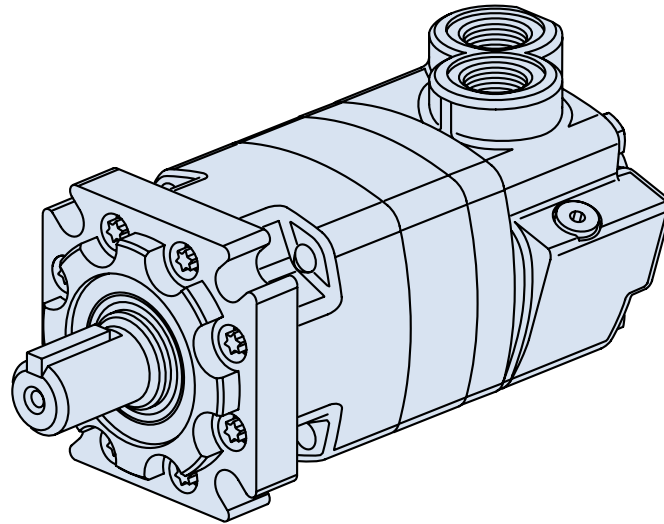

Features

- 10 displacements, a variety of mounting flanges and output shafts
- Reliable, proven design
- High efficiency
- Environmental protection options

Benefits

- Flexibility in designing this motor into a system
- Options that fit well into tough applications

Applications

- Mowing
- Snow Removal
- Sprayer
- Trencher
- Wood Products

Description

The 4000 Series offers up to 8600 in-lb of torque and 25 gpm (continuous ratings). This is the corner stone of the Char-Lynn line.

4000 Series Motors

Geroler Element	10 Displacements
Flow l/min [GPM]	95 [25] Continuous** 150 [40] Intermittent*
Speed RPM	722 Cont.** 868 Inter.*
Pressure bar [PSI]	200 [3000] Cont.** 300 [4500] Inter.*
Torque Nm [lb-in]	970 [8600] Cont.** 1180 [10450] Inter.*

** Continuous— (Cont.) Continuous rating, motor may be run continuously at these ratings

* Intermittent— (Inter.) Intermittent operation, 10% of every minute.



Mowing



Snow Removal



Sprayer



Trencher

4000 Series

Specifications

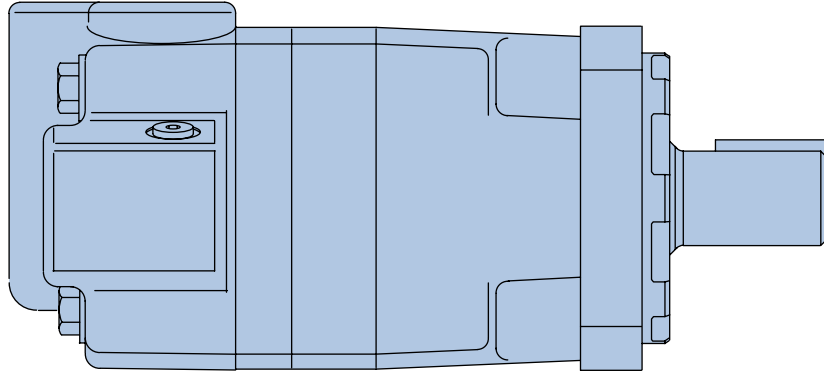

4000 SERIES MOTORS

Displ. cm ³ /r [in ³ /r]		110 [6.7]	130 [7.9]	160 [9.9]	205 [12.5]	245 [15.0]	280 [17.1]	310 [19.0]	395 [24.0]	495 [30.0]	625 [38.0]
Max. Speed (RPM)	Continuous	697	722	582	459	383	336	303	239	191	151
	Intermittent	868	862	693	546	532	488	422	376	305	241
@ Flow											
Flow l/min [GPM]	Continuous	75 [20]	95 [25]	95 [25]	95 [25]	95 [25]	95 [25]	95 [25]	95 [25]	95 [25]	95 [25]
	Intermittent	95 [25]	115 [30]	115 [30]	115 [30]	130 [35]	130 [35]	130 [35]	150 [40]	150 [40]	150 [40]
Torque* Nm [lb-in]	Continuous	320 [2850]	375 [3330]	485 [4290]	600 [5300]	705 [6240]	753 [6666]	850 [7530]	930 [8240]	945 [8375]	970 [8605]
	Intermittent	470 [4160]	560 [4940]	705 [6240]	800 [7100]	845 [7470]	957 [8471]	1065 [9420]	1185 [10470]	1170 [10350]	1180 [10450]
Pressure Δ bar [Δ PSI]	Continuous	205 [3000]	205 [3000]	205 [3000]	205 [3000]	205 [3000]	205 [3000]	205 [3000]	190 [2750]	140 [2000]	115 [1700]
	Intermittent	310 [4500]	310 [4500]	310 [4500]	260 [3750]	310 [4500]	260 [3750]	260 [3750]	240 [3500]	170 [2500]	140 [2000]
	Peak	310 [4500]	310 [4500]	310 [4500]	310 [4500]	310 [4500]	310 [4500]	310 [4500]	295 [4250]	230 [3300]	180 [2600]
Weight kg [lb]	Standard or Wheel Mount	17.9 [39.5]	18.1 [40.0]	18.1 [40.0]	18.4 [40.5]	18.6 [41.0]	19.1 [42.0]	19.5 [43.0]	20.4 [45.0]	21.8 [48.0]	23.1 [51.0]
	Bearingless	14.1 [31.0]	14.3 [31.5]	14.1 [31.0]	14.5 [32.0]	14.7 [32.5]	15.2 [33.5]	15.6 [34.5]	16.6 [36.5]	17.9 [39.5]	19.3 [42.5]

Maximum Case Pressure: See case pressure seal limitation graph.

*See shaft torque ratings for limitations..

Note:

To assure best motor life, run motor for approximately one hour at 30% of rated pressure before application to full load. Be sure motor is filled with fluid prior to any load applications.

Maximum Inlet Pressure:

310 bar [4500 PSI]
Do not exceed Δ pressure rating (see chart above).

Maximum Return Pressure:

310 bar [4500 PSI] with case drain line installed.
Do not exceed Δ pressure rating (see chart above).

Δ bar [Δ PSI] :

The true pressure difference between inlet port and outlet port

Continuous Rating:

Motor may be run continuously at these ratings

Intermittent Operation:

10% of every minute

Peak Operation:

1% of every minute

Recommended Fluids:

Premium quality, anti-wear type hydraulic oil with a viscosity of not less than 70 SUS at operating temperature.

Recommended Maximum System Operating Temp.:

82° C [180° F]

Recommended Filtration:





per ISO Cleanliness Code, 4406: 20/18/13

4000 Series

Performance Data

Motors run with high efficiency in all areas designated with a number for torque and speed. For best motor life select a motor to run with a torque and speed range shown in the light shaded area.

Performance data is typical at 120 SUS. Actual data may vary slightly from unit to unit in production.

	Continuous		Peak
	Intermittent		No Operation

110 cm³/r [6.7 in³/r]
 Δ Pressure Bar [PSI]

	[250]	[500]	[1000]	[1500]	[2000]	[2500]	[3000]	[3500]	[4000]	[4500]
	15	35	70	105	140	170	205	240	275	310
[.5]	[150]	[390]	[850]	[1290]						
1,9	15 14	45 10	95 5	145 2						
[1]	[170]	[440]	[900]	[1380]	[1860]	[2270]	[2680]	[3110]		
3,8	20 34	50 33	100 31	155 28	210 25	255 22	305 18	350 11		
[2]	[180]	[450]	[910]	[1390]	[1860]	[2280]	[2700]	[3120]	[3450]	
7,5	20 68	50 67	105 62	155 56	210 50	260 44	305 36	355 28	390 18	
[4]	[190]	[460]	[940]	[1400]	[1870]	[2310]	[2730]	[3140]	[3560]	[3880]
15	20 138	50 136	105 123	160 110	210 97	260 84	310 70	355 56	400 42	440 28
[6]	[200]	[470]	[960]	[1420]	[1880]	[2320]	[2760]	[3200]	[3640]	[3950]
23	25 207	55 204	110 200	160 193	210 184	260 174	310 163	360 150	410 136	455 121
[8]	[190]	[460]	[950]	[1420]	[1880]	[2340]	[2790]	[3230]	[3670]	[4010]
30	20 277	50 274	105 270	160 262	210 253	265 241	315 228	365 213	415 196	455 179
[10]	[180]	[460]	[950]	[1420]	[1890]	[2350]	[2820]	[3260]	[3700]	[4070]
38	20 347	50 344	105 340	160 331	210 322	265 308	320 292	370 274	420 255	460 236
[12]	[160]	[450]	[940]	[1420]	[1880]	[2350]	[2820]	[3260]	[3710]	[4080]
45	20 417	50 414	105 410	160 400	210 390	265 374	320 355	370 335	420 313	460 292
[14]	[140]	[440]	[930]	[1420]	[1880]	[2350]	[2830]	[3280]	[3730]	[4110]
53	15 487	50 484	105 480	160 469	210 458	265 440	320 419	370 446	420 471	465 348
[16]	[130]	[440]	[920]	[1410]	[1870]	[2350]	[2840]	[3300]	[3750]	[4120]
61	15 556	50 553	105 549	160 537	210 525	265 505	320 482	375 455	425 428	465 404
[18]	[100]	[440]	[910]	[1400]	[1870]	[2350]	[2840]	[3300]	[3770]	[4140]
68	10 626	50 622	105 618	160 606	210 593	265 570	320 545	375 516	425 485	465 460
[20]	[80]	[430]	[900]	[1370]	[1860]	[2350]	[2850]	[3320]	[3790]	[4160]
76	10 697	50 694	100 690	155 677	210 664	265 638	320 611	375 579	430 545	470 518
[25]		[400]	[860]	[1350]	[1850]	[2320]	[2830]	[3300]	[3780]	
95		45 868	95 861	155 838	210 816	260 792	320 767	375 729	425 690	

130 cm³/r [7.9 in³/r]
 Δ Pressure Bar [PSI]

	[250]	[500]	[1000]	[1500]	[2000]	[2500]	[3000]	[3500]	[4000]	[4500]
	15	35	70	105	140	170	205	240	275	310
[.5]	[310]	[510]	[1060]	[1590]						
1,9	35 12	60 9	120 5	180 2						
[1]	[290]	[530]	[1080]	[1600]	[2110]	[2640]	[3060]	[3450]		
3,8	35 30	60 28	120 25	180 19	240 14	300 13	345 12	390 4		
[2]	[280]	[530]	[1100]	[1620]	[2140]	[2660]	[3180]	[3600]	[4020]	[4080]
7,5	30 57	60 56	125 53	185 47	240 42	300 40	360 38	405 29	455 20	460 12
[4]	[260]	[520]	[1100]	[1650]	[2200]	[2700]	[3210]	[3660]	[4100]	[4560]
15	30 116	60 114	125 111	185 105	250 100	305 95	365 90	415 70	465 50	515 37
[6]	[240]	[510]	[1100]	[1650]	[2200]	[2720]	[3240]	[3710]	[4180]	[4660]
23	25 173	60 170	125 167	185 161	250 156	305 149	365 142	420 123	470 104	525 91
[8]	[230]	[510]	[1080]	[1640]	[2210]	[2740]	[3270]	[3770]	[4270]	[4750]
30	25 228	60 225	120 222	185 216	250 210	310 202	370 194	425 176	480 158	535 145
[10]	[210]	[510]	[1080]	[1640]	[2210]	[2750]	[3300]	[3820]	[4350]	[4840]
38	25 283	60 281	120 278	185 272	250 266	310 256	375 246	430 229	490 212	545 189
[12]	[200]	[500]	[1070]	[1640]	[2220]	[2750]	[3300]	[3840]	[4370]	[4870]
45	25 341	55 338	120 335	185 329	250 323	310 312	375 300	435 282	495 263	550 237
[14]	[180]	[490]	[1060]	[1640]	[2220]	[2750]	[3310]	[3860]	[4390]	[4890]
53	20 400	55 396	120 392	185 386	250 380	310 368	375 355	435 335	495 315	550 286
[16]	[160]	[490]	[1050]	[1630]	[2220]	[2760]	[3310]	[3860]	[4400]	[4920]
61	20 457	55 453	120 449	185 443	250 437	310 424	375 410	435 388	495 366	555 335
[18]	[130]	[480]	[1050]	[1630]	[2220]	[2760]	[3320]	[3870]	[4420]	[4940]
68	15 516	55 511	120 506	185 500	250 494	310 480	375 465	435 442	500 418	560 384
[20]	[110]	[470]	[1040]	[1620]	[2210]	[2760]	[3330]	[3890]	[4440]	
76	10 574	55 569	120 564	185 559	250 551	310 536	375 520	440 495	500 470	
[22]	[70]	[450]	[1020]	[1610]	[2190]	[2750]	[3320]	[3880]	[4440]	
83	10 633	50 628	115 624	180 615	245 606	310 590	375 573	440 547	500 520	
[25]	[50]	[430]	[1000]	[1580]	[2160]	[2720]	[3300]	[3860]	[4430]	
95	5 722	50 718	115 714	180 702	245 690	305 672	375 653	435 625	500 595	
[30]		[400]	[940]	[1500]	[2080]	[2670]	[3200]	[3740]		
114		45 862	105 855	170 842	235 827	300 806	360 783	425 749		

[3780] Torque [lb-in]
 425 Nm
 690 Speed RPM

4000 Series

Performance Data

Motors run with high efficiency in all areas designated with a number for torque and speed. For best motor life select a motor to run with a torque and speed range shown in the light shaded area.

Performance data is typical at 120 SUS. Actual data may vary slightly from unit to unit in production.

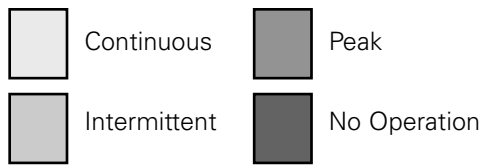

205 cm³/r [12.5 in³/r] Δ Pressure Bar [PSI]

	[250] 15	[500] 35	[1000] 70	[1500] 105	[2000] 140	[2500] 170	[3000] 205	[3500] 240	[4000] 275	[4500] 310
[.5] 1.9	[400] 45 8	[810] 90 5	[1500] 170 1							
[1] 3.8	[410] 45 17	[830] 95 17	[1590] 180 16	[2220] 250 15	[2860] 325 14	[3860] 435 12	[4560] 515 11	[5390] 610 9	[5510] 625 3	
[2] 7.5	[420] 45 36	[850] 95 35	[1680] 190 34	[2410] 270 32	[3140] 355 29	[4060] 460 27	[4800] 540 25	[5420] 610 22	[6000] 680 16	[6210] 700 8
[4] 15	[430] 50 73	[870] 100 73	[1770] 200 71	[2590] 295 70	[3410] 385 68	[4260] 480 61	[5040] 570 57	[5730] 645 45	[6340] 715 35	[6740] 760 23
[6] 23	[430] 50 107	[880] 100 106	[1800] 205 105	[2620] 295 103	[3530] 400 101	[4370] 495 98	[5170] 585 90	[5900] 665 81	[6590] 745 74	[7100] 800 65
[8] 30	[410] 45 144	[870] 100 143	[1820] 205 142	[2660] 300 138	[3560] 400 136	[4410] 500 132	[5240] 590 125	[6020] 680 116	[6770] 765 109	
[10] 38	[390] 45 182	[860] 95 180	[1820] 205 179	[2700] 305 174	[3580] 405 170	[4460] 505 166	[5300] 600 160	[6110] 690 152	[6890] 780 143	
[12] 45	[350] 40 217	[850] 95 216	[1810] 205 215	[2690] 305 211	[3570] 405 202	[4440] 500 200	[5300] 600 194	[6120] 690 185		
[14] 53	[330] 35 256	[840] 95 254	[1790] 200 252	[2670] 300 248	[3560] 400 243	[4430] 500 237	[5290] 600 229	[6120] 690 219		
[16] 61	[290] 35 291	[820] 95 290	[1770] 200 289	[2650] 300 284	[3540] 400 280	[4410] 500 272	[5280] 595 264	[6120] 690 253		
[18] 68	[270] 30 329	[810] 90 327	[1750] 200 325	[2640] 300 321	[3520] 400 316	[4400] 495 308	[5270] 595 298	[6120] 690 287		
[20] 76	[230] 25 366	[800] 90 364	[1730] 195 362	[2620] 295 358	[3510] 395 353	[4380] 495 345	[5270] 595 334	[6120] 690 321		
[22] 83	[190] 20 402	[780] 90 400	[1690] 190 398	[2600] 295 394	[3500] 395 389	[4370] 495 380	[5260] 595 368			
[25] 95	[150] 15 459	[750] 85 456	[1640] 185 453	[2560] 290 448	[3480] 395 442	[4360] 495 434	[5240] 590 421			
[30] 114		[710] 80 546	[1540] 175 542	[2510] 285 537	[3350] 380 529	[4190] 475 520	[5030] 570 504			

160 cm³/r [9.9 in³/r] Δ Pressure Bar [PSI]

	[250] 15	[500] 35	[1000] 70	[1500] 105	[2000] 140	[2500] 170	[3000] 205	[3500] 240	[4000] 275	[4500] 310
[.5] 1.9	[300] 35 8	[680] 75 7	[1320] 150 5	[2050] 230 3	[2750] 310 1					
[1] 3.8	[320] 35 23	[700] 80 22	[1350] 155 20	[2070] 235 19	[2780] 315 18	[3300] 375 16	[3940] 445 15	[4410] 500 8	[4950] 560 2	
[2] 7.5	[330] 35 46	[700] 80 45	[1360] 155 41	[2080] 235 40	[2790] 315 37	[3340] 375 32	[3970] 450 29	[4530] 510 27	[5090] 575 25	[5590] 630 13
[4] 15	[320] 35 93	[710] 80 92	[1400] 160 90	[2100] 240 88	[2820] 320 84	[3420] 385 76	[4020] 455 73	[4620] 520 62	[5220] 590 51	[5730] 645 35
[6] 23	[300] 35 137	[710] 80 135	[1420] 160 134	[2140] 240 131	[2850] 320 126	[3510] 395 120	[4180] 470 114	[4760] 540 90	[5340] 605 75	[5870] 665 57
[8] 30	[280] 30 184	[720] 80 182	[1450] 165 180	[2180] 245 176	[2900] 330 171	[3560] 400 163	[4230] 480 154	[4850] 550 138	[5470] 620 122	[6010] 680 100
[10] 38	[260] 30 232	[720] 80 229	[1480] 165 226	[2220] 250 221	[2950] 335 216	[3610] 410 206	[4290] 485 194	[4920] 555 182	[5560] 630 169	[6160] 695 142
[12] 45	[240] 25 277	[700] 80 274	[1450] 165 272	[2190] 245 266	[2920] 330 260	[3590] 405 250	[4280] 485 238	[4920] 555 224	[5570] 630 209	[6180] 700 182
[14] 53	[220] 25 321	[680] 75 319	[1420] 160 318	[2160] 245 311	[2890] 325 304	[3570] 405 294	[4270] 480 282	[4920] 555 266	[5580] 630 249	[6200] 700 222
[16] 61	[200] 25 366	[670] 75 364	[1400] 160 362	[2130] 240 356	[2860] 325 348	[3550] 400 338	[4260] 480 326	[4920] 555 308	[5590] 630 289	[6220] 705 262
[18] 68	[180] 20 410	[650] 75 409	[1360] 155 407	[2100] 235 401	[2830] 320 392	[3530] 400 382	[4250] 480 370	[4910] 555 350	[5600] 635 329	[6240] 705 302
[20] 76	[150] 15 460	[630] 70 458	[1340] 150 456	[2070] 235 448	[2800] 315 440	[3510] 395 429	[4240] 480 417	[4910] 555 396	[5610] 635 373	
[22] 83	[120] 15 509	[620] 70 506	[1330] 150 502	[2060] 235 494	[2790] 315 484	[3500] 395 473	[4220] 475 461	[4910] 555 438	[5600] 635 413	
[25] 95	[70] 10 582	[600] 70 578	[1320] 150 573	[2050] 230 563	[2780] 315 552	[3480] 395 540	[4210] 475 526	[4900] 555 501	[5590] 630 474	
[30] 114		[560] 65 693	[1280] 145 687	[1990] 225 675	[2700] 305 661	[3430] 390 647	[3970] 450 630	[4640] 525 600		

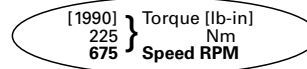





4000 Series

245 cm³/r [15.0 in³/r]
Δ Pressure Bar [PSI]

Performance Data

Motors run with high efficiency in all areas designated with a number for torque and speed. For best motor life select a motor to run with a torque and speed range shown in the light shaded area.

Performance data is typical at 120 SUS. Actual data may vary slightly from unit to unit in production.

	Continuous		Peak
	Intermittent		No Operation

	[250] 15	[500] 35	[750] 50	[1000] 70	[1250] 85	[1500] 105	[1750] 120	[2000] 140	[2250] 155	[2500] 170	[2750] 190	[3000] 205	[3250] 225	[3500] 240	[3750] 260
[.5] 1.9	[460] 50 5	[980] 110 2													
[1] 3.8	[480] 55 14	[990] 110 14	[1490] 170 14	[1990] 225 13	[2480] 280 13	[2970] 335 12	[3400] 385 12	[3830] 435 11	[4250] 480 11	[4680] 530 10	[5020] 565 4				
[2] 7.5	[500] 55 30	[1000] 115 170	[1520] 170 29	[2040] 230 29	[2540] 285 28	[3050] 345 27	[3420] 385 26	[3930] 445 24	[4440] 500 23	[4900] 555 22	[5320] 600 20	[5740] 650 18	[6160] 695 16	[6640] 750 14	[7150] 810 11
[4] 15	[510] 60 61	[1030] 115 61	[1560] 175 60	[2080] 235 60	[2600] 295 59	[3130] 355 59	[3630] 415 58	[4130] 465 56	[4630] 525 53	[5120] 580 49	[5570] 645 47	[6030] 705 44	[6480] 770 42	[6970] 830 39	[7340] 890 36
[6] 23	[510] 60 91	[1040] 115 90	[1570] 175 90	[2100] 235 89	[2620] 295 88	[3160] 355 88	[3660] 415 86	[4200] 475 83	[4710] 530 80	[5220] 590 75	[5690] 645 72	[6150] 705 67	[6620] 750 67	[7050] 800 63	[7430] 840 59
[8] 30	[500] 55 121	[1020] 115 121	[1520] 175 120	[2100] 240 119	[2630] 295 118	[3150] 355 115	[3680] 415 113	[4210] 475 111	[4740] 535 109	[5250] 595 106	[5720] 645 103	[6200] 700 99	[6670] 755 96	[7090] 800 91	[7470] 845 87
[10] 38	[470] 55 152	[1000] 115 151	[1540] 175 150	[2100] 235 148	[2620] 295 148	[3150] 355 147	[3690] 415 145	[4230] 475 143	[4770] 535 141	[5290] 595 137	[5760] 645 133	[6240] 700 129	[6710] 755 125	[7140] 805 120	
[12] 45	[450] 50 183	[980] 110 182	[1530] 175 180	[2080] 235 179	[2610] 295 178	[3140] 355 178	[3680] 415 176	[4220] 475 173	[4760] 530 170	[5280] 595 166	[5750] 645 161	[6230] 700 157	[6700] 755 152		
[14] 53	[420] 45 213	[960] 110 212	[1520] 170 211	[2060] 235 210	[2600] 295 209	[3130] 355 208	[3670] 415 206	[4200] 475 203	[4740] 535 200	[5260] 595 195	[5740] 645 190	[6220] 705 185			
[16] 61	[400] 45 244	[950] 110 243	[1500] 170 242	[2040] 230 241	[2580] 290 240	[3120] 355 239	[3660] 415 236	[4190] 475 232	[4730] 530 229	[5250] 595 225	[5730] 645 219	[6210] 700 213			
[18] 68	[380] 45 275	[930] 105 274	[1480] 165 273	[2020] 230 272	[2560] 290 270	[3110] 350 269	[3650] 415 266	[4180] 470 262	[4710] 525 259	[5230] 590 254	[5720] 645 248	[6200] 700 241			
[20] 76	[350] 40 305	[910] 105 305	[1460] 165 304	[2000] 225 303	[2550] 290 302	[3100] 350 300	[3640] 410 296	[4170] 470 292	[4700] 530 288	[5220] 590 283	[5710] 645 276				
[22] 83	[310] 35 337	[870] 100 336	[1420] 160 335	[1970] 225 334	[2500] 280 332	[3050] 345 330	[3590] 405 326	[4140] 465 323	[4680] 525 319	[5200] 585 313	[5680] 640 306				
[25] 95	[260] 30 383	[820] 95 382	[1380] 155 381	[1930] 220 380	[2460] 280 378	[2980] 335 376	[3540] 400 372	[4090] 460 369	[4640] 525 365	[5180] 585 357					
[30] 114		[680] 75 457	[1250] 140 456	[1860] 210 455	[2390] 270 454	[2900] 330 450	[3430] 390 445	[3960] 445 442	[4460] 505 437	[4950] 560 427					
[35] 132			[1110] 125 532	[1740] 195 531	[2270] 255 528	[2790] 315 525	[3340] 375 519	[3910] 440 515	[4400] 495 509						

280 cm³/r [17.1 in³/r]
Δ Pressure Bar [PSI]

	[250] 15	[500] 35	[750] 50	[1000] 70	[1250] 85	[1500] 105	[1750] 120	[2000] 140	[2250] 155	[2500] 170	[2750] 190	[3000] 205	[3250] 225	[3500] 240	[3750] 260
[.5] 1.9	[533] 60 4	[1074] 121 2													
[1] 3.8	[553] 62 12	[1136] 128 12	[1714] 194 12	[2287] 258 11	[2841] 321 11	[3394] 384 10	[3868] 437 10	[4389] 496 10	[4895] 553 10	[6080] 685 8	[5870] 663 6	[368] 720 6	[6811] 770 6	[7239] 818 5	[7654] 865 4
[2] 7.5	[568] 64 26	[1146] 130 26	[1740] 197 25	[2328] 263 25	[2902] 328 24	[3461] 391 24	[3955] 447 23	[4524] 511 22	[2922] 330 21	[5630] 636 20	[6146] 694 19	[6666] 753 17	[7191] 813 17	[7749] 876 15	[8323] 940 13
[4] 15	[579] 65 53	[1167] 132 53	[1771] 200 52	[2374] 268 52	[2962] 335 51	[3557] 402 51	[4139] 468 50	[4712] 532 49	[5285] 597 47	[5848] 661 45	[6395] 722 44	[6946] 785 42	[7502] 848 41	[8020] 906 40	[8471] 957 38
[6] 23	[583] 66 79	[1177] 133 79	[1781] 201 78	[2395] 271 77	[2987] 338 77	[3601] 407 77	[4193] 474 76	[4793] 542 74	[5395] 607 72	[5959] 673 69	[6521] 737 66	[7082] 800 66	[7607] 859 65	[8097] 915 64	
[8] 30	[573] 65 106	[167] 132 106	[1780] 201 105	[2404] 272 105	[3007] 340 104	[3610] 408 104	[4218] 477 102	[4812] 544 101	[5411] 611 99	[5994] 677 96	[6556] 741 94	[7022] 793 92	[7518] 849 90		
[10] 38	[547] 62 134	[1146] 130 133	[1765] 199 133	[2395] 271 131	[2997] 339 131	[3629] 410 130	[4238] 479 129	[4837] 547 127	[5442] 615 126	[6035] 682 122	[6601] 746 119	[7022] 793 115	[7518] 849 111		
[12] 45	[527] 60 161	[1126] 127 160	[1745] 197 186	[2369] 268 158	[2991] 338 157	[3609] 408 157	[4228] 478 156	[4832] 546 154	[5441] 615 152	[6034] 682 148	[6586] 744 144	[6940] 784 141			
[14] 53	[497] 56 187	[1106] 125 187	[1730] 195 186	[2344] 265 186	[2972] 336 185	[3585] 405 184	[4213] 476 182	[4816] 544 180	[5430] 614 178	[6028] 681 174	[6511] 736 170	[6940] 784 166			
[16] 61	[472] 53 214	[1096] 124 214	[1715] 194 213	[2324] 263 212	[2947] 333 211	[3565] 403 210	[4203] 475 208	[4811] 544 206	[5420] 612 203	[5919] 669 199	[6436] 727 195				
[18] 68	[437] 39 241	[1075] 121 241	[1690] 191 240	[2299] 260 239	[2917] 330 237	[3541] 400 236	[4188] 473 234	[4801] 542 231	[5400] 610 229	[5919] 669 224	[6362] 719 219				
[20] 76	[402] 45 268	[1055] 119 268	[1669] 189 268	[2274] 257 267	[2898] 327 266	[3521] 398 264	[4178] 472 261	[4791] 541 258	[5394] 609 255	[5851] 661 249					
[22] 83	[366] 41 296	[1005] 114 295	[1629] 184 295	[2257] 255 294	[2856] 323 292	[3480] 393 290	[4136] 467 288	[4756] 537 285	[5205] 588 279						
[25] 95	[301] 34 336	[940] 106 336	[1588] 179 335	[2231] 252 334	[2825] 319 333	[3419] 386 331	[4086] 462 328	[4710] 532 325	[5205] 588 314						
[30] 114		[845] 96 402	[1480] 167 401	[2151] 243 400	[2759] 312 398	[3328] 376 396	[3984] 450 392	[4573] 517 389	[5021] 567 377						
[35] 132			[1348] 152 468	[2057] 232 466	[2623] 296 464	[3183] 360 463	[3883] 439 457	[4354] 492 449							





{3340 } Torque [lb-in]
375 Nm
519 Speed RPM

4000 Series

Performance Data

Motors run with high efficiency in all areas designated with a number for torque and speed. For best motor life select a motor to run with a torque and speed range shown in the light shaded area.

Performance data is typical at 120 SUS. Actual data may vary slightly from unit to unit in production.

	Continuous		Peak
	Intermittent		No Operation

310 cm³/r [19.0 in³/r]
Δ Pressure Bar [PSI]

	[250] 15	[500] 35	[750] 50	[1000] 70	[1250] 85	[1500] 105	[1750] 120	[2000] 140	[2250] 155	[2500] 170	[2750] 190	[3000] 205	[3250] 225	[3500] 240	[3750] 260
[.5] 1,9	[600] 70 4	[1150] 130 2													
[1] 3,8	[620] 70 11	[1270] 145 11	[1920] 215 11	[2560] 290 10	[3170] 360 10	[3780] 425 10	[4290] 485 9	[4900] 555 9	[5490] 620 9	[6080] 685 8	[6670] 755 8	[7270] 820 7	[7880] 890 7	[8490] 960 6	[9080] 1025 5
[2] 7,5	[630] 70 23	[1280] 145 23	[1940] 220 22	[2590] 295 22	[3230] 365 21	[3830] 435 21	[4450] 505 20	[5070] 575 20	[5680] 640 19	[6300] 710 18	[6910] 780 18	[7530] 850 17	[8160] 920 17	[8790] 995 16	[9420] 1065 15
[4] 15	[640] 70 47	[1290] 145 47	[1960] 220 46	[2640] 300 46	[3290] 370 45	[3940] 445 45	[4600] 520 44	[5240] 590 44	[5880] 665 43	[6510] 735 42	[7150] 810 42	[7790] 880 41	[8450] 955 41	[9100] 1030 40	
[6] 23	[650] 75 71	[1300] 145 71	[1970] 225 70	[2660] 300 70	[3320] 375 69	[4000] 450 69	[4680] 530 68	[5330] 600 67	[5980] 675 66	[6630] 750 66	[7280] 825 64	[7940] 895 63			
[8] 30	[640] 70 96	[1300] 145 96	[1980] 225 95	[2670] 300 95	[3350] 380 94	[4030] 455 94	[4710] 530 93	[5360] 605 92	[6020] 680 91	[6670] 755 91	[7320] 825 89				
[10] 38	[620] 70 121	[1280] 145 120	[1970] 225 120	[2660] 300 119	[3340] 375 119	[4070] 460 118	[4740] 535 117	[5390] 610 116	[6050] 685 115	[6710] 760 112	[7370] 835 109				
[12] 45	[600] 70 145	[1260] 140 144	[1940] 220 144	[2630] 295 143	[3340] 375 142	[4040] 455 142	[4740] 535 141	[5390] 610 140	[6060] 685 139	[6720] 760 135					
[14] 53	[570] 65 169	[1240] 140 169	[1920] 215 168	[2600] 295 168	[3310] 375 167	[4000] 450 167	[4710] 530 165	[5380] 610 164	[6060] 685 163	[6730] 760 159					
[16] 61	[540] 60 193	[1230] 140 193	[1900] 215 192	[2580] 290 192	[3280] 370 190	[3970] 450 189	[4700] 530 188	[5380] 610 187	[6050] 685 185						
[18] 68	[490] 55 217	[1210] 135 217	[1880] 210 216	[2550] 290 216	[3240] 365 214	[3930] 445 213	[4680] 530 211	[5370] 605 209	[6040] 680 207						
[20] 76	[450] 50 242	[1190] 135 242	[1860] 210 242	[2520] 285 241	[3210] 365 240	[3900] 440 238	[4670] 530 236	[5360] 605 234	[6030] 680 232						
[22] 83	[420] 45 267	[1130] 130 266	[1820] 205 266	[2520] 285 265	[3180] 360 264	[3870] 440 262	[4640] 525 260	[5320] 600 258							
[25] 95	[340] 40 303	[1050] 120 303	[1780] 200 302	[2510] 285 301	[3160] 355 300	[3820] 430 299	[4590] 520 296	[5280] 595 293							
[30] 114		[1010] 115 363	[1700] 190 362	[2420] 275 360	[3100] 350 359	[3720] 420 358	[4500] 510 354	[5140] 580 351							
[35] 132			[1580] 180 422	[2360] 265 420	[2950] 335 419	[3540] 400 418	[4390] 495 413								

395 cm³/r [24.0 in³/r]
Δ Pressure Bar [PSI]

	[250] 15	[500] 35	[750] 50	[1000] 70	[1250] 85	[1500] 105	[1750] 120	[2000] 140	[2250] 155	[2500] 170	[2750] 190	[3000] 205	[3250] 225	[3500] 240
[.5] 1,9	[700] 80 4	[1340] 150 2												
[1] 3,8	[750] 85 9	[1430] 160 9	[2110] 240 8	[2770] 315 8	[3460] 390 8	[4170] 470 7	[4890] 550 7	[5610] 635 7	[6310] 715 5	[7010] 790 4	[7700] 870 2			
[2] 7,5	[800] 90 18	[1500] 170 18	[2290] 260 17	[3030] 340 16	[3850] 435 16	[4620] 520 15	[5310] 600 15	[6000] 680 14	[6750] 765 13	[7490] 845 13	[8240] 930 12	[8990] 1015 11	[9730] 1100 10	[10470] 1185 8
[4] 15	[860] 95 38	[1630] 185 38	[2470] 280 37	[3310] 375 36	[4120] 465 36	[4900] 555 35	[5640] 635 35	[6390] 720 34	[7190] 810 34	[7890] 890 33	[8780] 990 32			
[6] 23	[860] 95 57	[1690] 190 57	[2540] 285 56	[3410] 385 55	[4180] 470 54	[4980] 565 53	[5780] 655 52	[6580] 745 50	[7400] 835 49	[8220] 930 47				
[8] 30	[840] 95 76	[1680] 190 76	[2550] 290 75	[3400] 385 74	[4260] 480 73	[5090] 575 72	[5870] 665 70	[6650] 750 68	[7480] 845 66					
[10] 38	[800] 90 95	[1680] 190 95	[2550] 290 94	[3400] 385 93	[4260] 480 92	[5100] 575 91	[5920] 670 89	[6730] 760 86	[7560] 855 84					
[12] 45	[760] 85 114	[1660] 190 114	[2520] 285 113	[3380] 380 112	[4270] 480 111	[5110] 575 110	[5900] 665 108	[6690] 755 105						
[14] 53	[740] 85 133	[1640] 185 133	[2490] 280 132	[3370] 380 131	[4260] 480 130	[5100] 575 129	[5880] 665 127	[6650] 750 124						
[16] 61	[710] 80 153	[1620] 185 153	[2460] 280 152	[3350] 380 151	[4240] 480 149	[5080] 575 147	[5840] 660 145							
[18] 68	[680] 75 172	[1600] 180 172	[2430] 275 171	[3340] 375 170	[4220] 475 168	[5060] 570 166	[5810] 655 164							
[20] 76	[610] 70 192	[1580] 180 191	[2400] 270 190	[3320] 375 189	[4210] 475 187	[5040] 570 185	[5780] 655 183							
[22] 83	[570] 65 211	[1490] 170 210	[2340] 265 209	[3220] 365 208	[4160] 470 206	[5010] 565 204	[5740] 650 201							
[25] 95	[490] 55 239	[1350] 155 238	[2250] 255 237	[3080] 350 236	[4070] 460 235	[4960] 560 233	[5700] 645 230							
[30] 114		[1080] 120 285	[1650] 185 284	[2270] 255 282	[3020] 340 281	[3850] 435 279								
[35] 132			[1520] 170 331	[2120] 240 330	[2870] 325 328	[3760] 425 325								
[40] 151				[2050] 230 376	[2790] 315 374	[3620] 410 371								

[4390] Torque [lb-in]
495 Nm
413 Speed RPM

4000 Series

Performance Data

Motors run with high efficiency in all areas designated with a number for torque and speed. For best motor life select a motor to run with a torque and speed range shown in the light shaded area.

Performance data is typical at 120 SUS. Actual data may vary slightly from unit to unit in production.

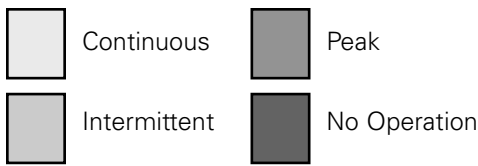

625 cm³/r [38.0 in³/r]
Δ Pressure Bar [PSI]

	[250] 15	[500] 35	[750] 50	[1000] 70	[1250] 85	[1500] 105	[1600] 100	[1700] 115	[1800] 125	[2000] 140
[.5] 1.9	[1000] 115 2									
[1] 3.8	[1080] 120 5	[2340] 265 5	[3600] 405 4	[4850] 550 4	[6100] 690 4	[7350] 830 3	[7820] 885 3	[8290] 935 2	[8760] 990 2	
[2] 7.5	[1085] 125 14	[2380] 270 14	[3675] 415 14	[5010] 565 13	[6350] 715 12	[7625] 860 11	[8115] 915 10	[8605] 970 9	[9095] 1030 8	[10075] 1140 7
[4] 15	[1090] 125 23	[2420] 275 23	[3750] 425 23	[5175] 585 22	[6600] 745 21	[7900] 895 19	[8410] 950 18	[9000] 1015 17	[9590] 1085 16	[10450] 1180 14
[6] 23	[1095] 125 35	[2460] 280 35	[3825] 430 35	[5220] 590 34	[6620] 750 33	[7950] 900 31	[8430] 950 30	[8910] 1005 29	[9490] 1070 28	
[8] 30	[1100] 125 48	[2500] 280 48	[3900] 440 47	[5270] 595 46	[6640] 750 45	[7990] 905 43	[8460] 955 43	[8925] 1010 42		
[10] 38	[1130] 130 60	[2550] 290 60	[3975] 450 59	[5320] 600 58	[6670] 755 57	[8045] 910 54	[8595] 970 53	[9150] 1035 52		
[12] 45	[1160] 130 72	[2600] 295 72	[4050] 460 71	[5375] 605 70	[6700] 755 69	[8100] 915 65	[8660] 980 64			
[14] 53	[1105] 125 84	[2535] 285 84	[3965] 450 83	[5325] 600 82	[6685] 755 81	[8065] 910 77	[8620] 975 76			
[16] 61	[1050] 120 96	[2465] 280 95	[3880] 440 95	[5275] 595 94	[6670] 755 93	[8035] 910 89	[8580] 970 88			
[18] 68	[990] 110 108	[2405] 270 107	[3825] 430 107	[5240] 590 105	[6655] 750 104	[7345] 830 100				
[20] 76	[930] 105 121	[2350] 265 120	[3770] 425 120	[5205] 590 118	[6640] 750 116					
[25] 95	[750] 85 151	[2175] 245 150	[3600] 405 149	[5000] 565 147	[6400] 725 146					
[30] 114	[550] 60 181	[1975] 225 180	[3400] 385 179	[4800] 530 177	[6200] 700 176					
[35] 132			[3125] 355 210	[4545] 515 208						
[40] 151			[2850] 320 241	[4295] 485 239						

495 cm³/r [30.0 in³/r]
Δ Pressure Bar [PSI]

	[250] 15	[500] 35	[750] 50	[1000] 70	[1250] 85	[1500] 105	[1750] 120	[2000] 140	[2250] 155	[2500] 170
[.5] 1.9	[800] 90 3	[1750] 200 1								
[1] 3.8	[880] 100 7	[1875] 210 6	[2875] 325 6	[3825] 430 5	[4775] 540 4	[5720] 645 3	[6670] 755 2	[7600] 860 1		
[2] 7.5	[905] 100 18	[1940] 220 17	[2975] 335 17	[3990] 450 16	[5010] 565 15	[6010] 680 12	[7010] 790 11	[8000] 905 10	[8980] 1015 8	
[4] 15	[935] 105 30	[2005] 225 29	[3075] 345 28	[4160] 470 27	[5245] 595 26	[6300] 710 23	[7355] 830 21	[8375] 945 19	[9400] 1060 17	[10350] 1170 14
[6] 23	[920] 105 45	[2010] 225 44	[3100] 350 43	[4185] 475 42	[5265] 595 40	[6345] 715 37	[7420] 840 35	[8445] 955 32	[9465] 1070 30	
[8] 30	[905] 100 61	[2015] 230 60	[3125] 355 59	[4205] 475 57	[5290] 600 55	[6385] 720 52	[7485] 845 49	[8510] 960 46		
[10] 38	[880] 100 76	[1995] 225 75	[3095] 350 74	[4205] 475 72	[5295] 600 70	[6390] 720 66	[7480] 845 63	[8525] 960 59		
[12] 45	[860] 95 91	[1975] 225 90	[3095] 350 89	[4200] 475 87	[5305] 600 85	[6390] 720 81	[7475] 845 77			
[14] 53	[830] 95 106	[1945] 220 105	[3055] 345 104	[4165] 470 102	[5275] 595 100	[6360] 720 96	[7445] 840 92			
[16] 61	[805] 90 122	[1910] 215 120	[3020] 340 119	[4130] 465 117	[5245] 595 115	[6330] 715 111	[7420] 840 107			
[18] 68	[740] 85 137	[1860] 210 136	[2980] 335 134	[4105] 465 132	[5235] 590 130	[6305] 715 125	[7380] 835 121			
[20] 76	[680] 75 153	[1810] 205 152	[2940] 330 150	[4085] 460 147	[5225] 590 145	[6285] 710 140				
[25] 95	[570] 65 191	[1665] 190 189	[2800] 315 187	[4005] 455 184	[5210] 590 182	[6135] 695 177				
[30] 114		[1520] 170 228	[2645] 300 226	[3765] 425 223	[4885] 550 220	[5985] 675 215				
[35] 132			[2400] 270 265	[3510] 395 263						
[40] 151				[2155] 245 305	[3260] 370 303					

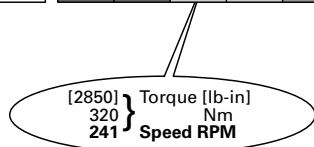

4000 Series

Dimensions

Ports

- 1 1/16 -12 UN-2B SAE O-ring Staggered Ports (2)
- 7/16 -20 UNF-2B SAE O-ring Case Drain Port (1) or
- 4 Bolt 3/4 inch Split Flange Ports (2)
- 7/16 -20 UNF-2B SAE O-ring Case Drain Port (1) or
- G 3/4 (BSP) Staggered Ports (2)
- G 1/4 (BSP) Case Drain Port (1) or

Standard Rotation Viewed from Shaft End

- Port A Pressurized — CW
- Port B Pressurized — CCW

Standard Mount

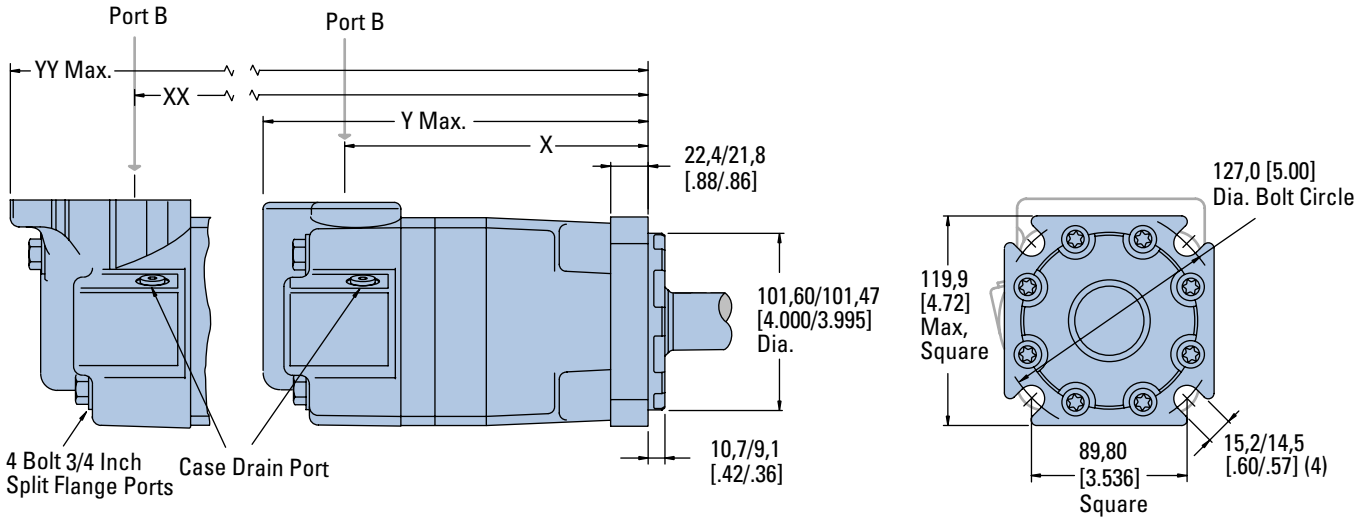

SAE C Flange

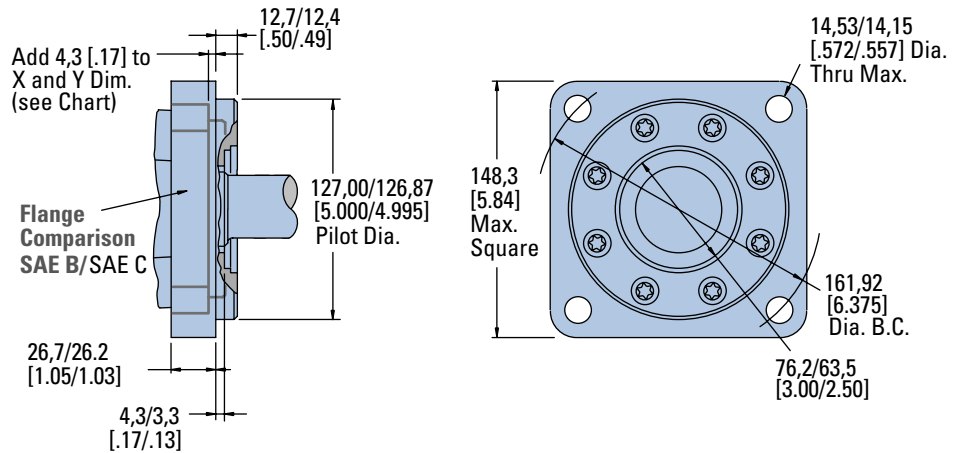

STANDARD MOUNT MOTOR DIMENSIONS

Displacement cm ³ /r [in ³ /r]	X mm [inch]	Y mm [inch]	XX mm [inch]	YY mm [inch]
110 [6.7]	158,3 [6.23]	214,4 [8.44]	167,3 [6.59]	246,3 [9.70]
130 [7.9]	162,3 [6.39]	218,4 [8.60]	171,3 [6.75]	250,4 [9.86]
160 [9.9]	168,7 [6.64]	224,7 [8.85]	177,7 [7.00]	256,7 [10.11]
205 [12.5]	177,2 [6.98]	233,2 [9.18]	186,2 [7.33]	265,2 [10.44]
245 [15.0]	168,7 [6.64]	224,7 [8.85]	177,7 [7.00]	256,7 [10.11]
310 [19.0]	177,2 [6.98]	233,2 [9.18]	186,2 [7.33]	265,2 [10.44]
395 [24.0]	187,9 [7.40]	243,9 [9.60]	196,9 [7.75]	275,9 [10.86]
495 [30.0]	200,7 [7.90]	256,8 [10.11]	209,7 [8.26]	288,8 [11.37]
625 [38.0]	217,8 [8.58]	273,9 [10.78]	226,7 [8.93]	305,9 [12.04]

4000 Series

Dimensions

Wheel Mount

Ports

- 1 1/16 -12 UN-2B SAE O-ring Staggered Ports (2)
- 7/16 -20 UNF-2B SAE O-ring Case Drain Port (1) or
- 4 Bolt 3/4 inch Split Flange Ports (2)
- 7/16 -20 UNF-2B SAE O-ring Case Drain Port (1) or
- G 3/4 (BSP) Staggered Ports (2)
- G 1/4 (BSP) Case Drain Port (1)

Standard Rotation Viewed from Shaft End

- Port A Pressurized — CW
- Port B Pressurized — CCW

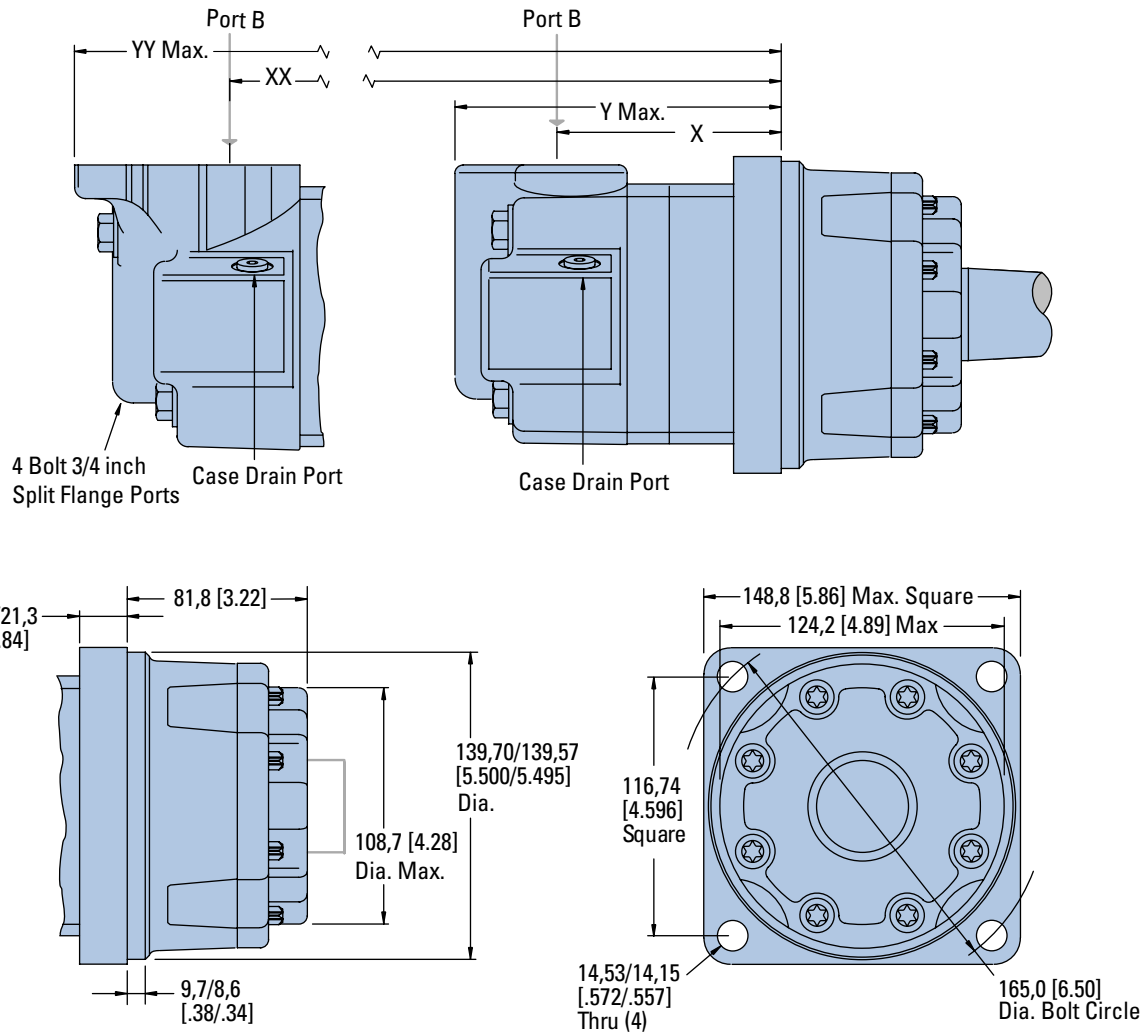

WHEEL MOUNT MOTOR DIMENSIONS

Displacement cm ³ /r [in ³ /r]	X mm [inch]	Y mm [inch]	XX mm [inch]	YY mm [inch]
110 [6.7]	87,5 [3.45]	143,3 [5.64]	96,4 [3.80]	175,3 [6.90]
130 [7.9]	91,6 [3.61]	147,3 [5.80]	100,5 [3.96]	179,3 [7.06]
160 [9.9]	97,8 [3.85]	153,7 [6.05]	106,8 [4.21]	185,7 [7.31]
205 [12.5]	106,4 [4.19]	162,3 [6.39]	115,4 [4.55]	194,3 [7.65]
245 [15.0]	97,8 [3.85]	153,7 [6.05]	106,8 [4.21]	185,7 [7.31]
310 [19.0]	106,4 [4.19]	162,3 [6.39]	115,4 [4.55]	194,3 [7.65]
395 [24.0]	117,1 [4.61]	173,0 [6.81]	126,1 [4.97]	205,0 [8.07]
495 [30.0]	129,9 [5.12]	185,7 [7.31]	138,8 [5.47]	217,7 [8.57]
625 [38.0]	146,9 [5.79]	202,9 [7.99]	156,0 [6.14]	235,0 [9.25]

4000 Series

Dimensions

Bearingless

Ports

- 1 1/16 -12 UN-2B SAE O-ring Staggered Ports (2)
- 7/16 -20 UNF-2B SAE O-ring Case Drain Port (1) or
- 4 Bolt 3/4 inch Split Flange Ports (2)
- 7/16 -20 UNF-2B SAE O-ring Case Drain Port (1) or
- G 3/4 (BSP) Staggered Ports (2)
- G 1/4 (BSP) Case Drain Port (1)

Standard Rotation Viewed from Shaft End

- Port A Pressurized — CW
- Port B Pressurized — CCW

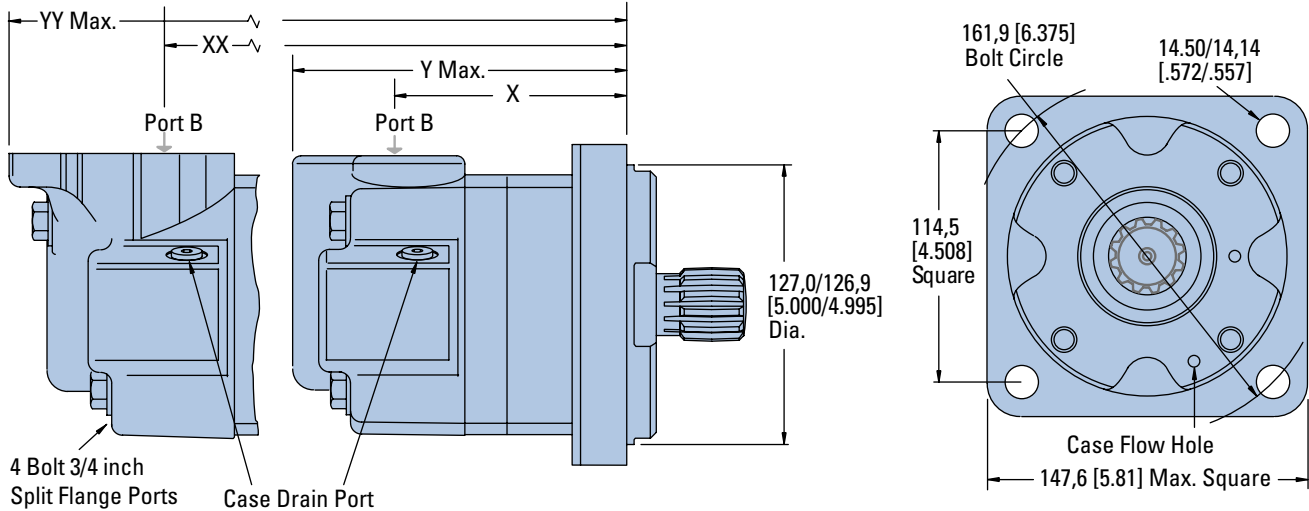

For 4000 Series Bearingless Motor application information contact your Eaton representative (mating coupling blanks available from Eaton Hydraulics).

Note:

After machining blank, part must be hardened per Eaton specification.

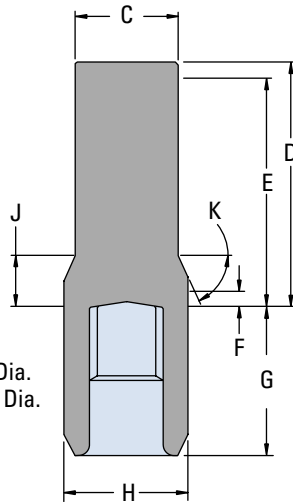

- C 47,2 [1.86] Dia.
- D 112,5 [4.43] Max.
- E 107,4 [4.23] Full Form Dia.
- F 7,4 [.29] Min. Full Form Dia.
- G 68,8 [2.71] Max.
- H 56,9 [2.24] Dia.
- J 18,29 [.720]
- K 38°

Mating Coupling Blank
Eaton Part No. 12745-003

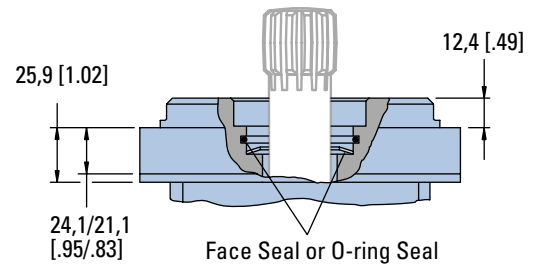
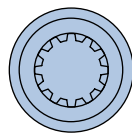

BEARINGLESS MOTOR DIMENSIONS

Displacement cm ³ /r [in ³ /r]	X mm [inch]	Y mm [inch]	XX mm [inch]	YY mm [inch]
110 [6.7]	91,0 [3.58]	146,8 [5.78]	100,1 [3.94]	178,8 [7.04]
130 [7.9]	95,0 [3.74]	150,8 [5.94]	104,1 [4.10]	182,9 [7.20]
160 [9.9]	101,4 [4.00]	157,1 [6.19]	110,5 [4.35]	189,2 [7.45]
205 [12.5]	109,9 [4.33]	165,7 [6.52]	118,9 [4.68]	197,6 [7.78]
245 [15.0]	101,4 [4.00]	157,1 [6.19]	110,5 [4.35]	189,2 [7.45]
310 [19.0]	109,9 [4.33]	165,7 [6.52]	118,9 [4.68]	197,6 [7.78]
395 [24.0]	120,6 [4.75]	176,3 [6.94]	129,5 [5.10]	208,3 [8.20]
495 [30.0]	133,5 [5.26]	189,2 [7.45]	142,5 [5.61]	221,2 [8.71]
625 [38.0]	150,5 [5.93]	206,3 [8.12]	159,5 [6.28]	238,3 [9.38]

4000 Series

Installation Information

Bearingless

- 1 Internal spline in mating part to be as follows: Material to be ASTM A304, 8620H. Carbonize to a hardness of 60-64 HRc with case depth (to 50HRc) of 0,076 - 1,27 [.030 - .050] (dimensions apply after heat treat).
- 2 Mating part to have critical dimensions as shown. Oil holes must be provided and open for proper oil circulation.
- 3 Seal to be furnished with motor for proper oil circulation thru splines.
- 4 Some means of maintaining clearance between shaft and mounting flange must be provided.
- 5 Counterbore designed to adapt to a standard sleeve bearing 50,010 - 50,040 [1.9689 - 1.9700] ID by 60,050 - 60,080 [2.3642 - 2.3653] (Oilite bronze sleeve bearing).
- 6 Similar to SAE "C" Four Bolt Flange.
- 7 52,8 [2.08] Max. dimension to be maintained when assembling shipping and installing unit to insure valve drive engagement with valve (this is required on displacement code number 24 only).

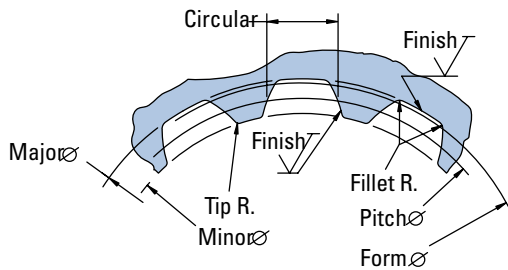
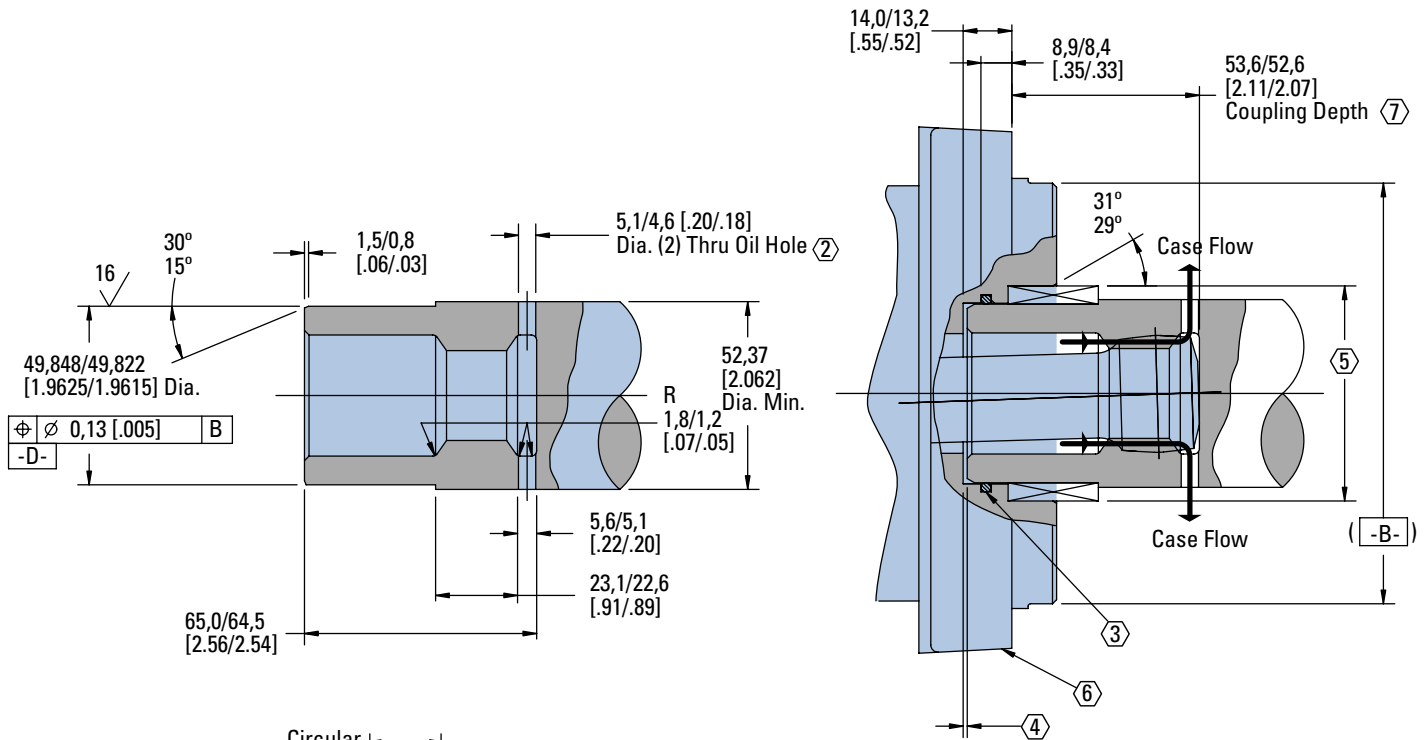

Spline Pitch.....	10/20
Pressure Angle.....	30°
Number of teeth.....	12
Class of Fit.....	Ref. 5
Type of Fit.....	Side
Pitch Diameter.....	Ref. 30,480000 [1.2000000] $\begin{matrix} \nearrow 0,20 [.008] \\ \searrow D \end{matrix}$
Base Diameter.....	Ref. 26,396455 [1.0392305]
Major Diameter.....	33,43 [1.316] Max. 33,23 [1.308] Min.
Min. Minor Diameter.....	28,40 - 28,58 [1.118 - 1.125]
Form Diameter, Min.....	32,59 [1.283]
Fillet Radius.....	0,63 - 0,76 [.025 - .030]
Tip Radius.....	0,26 - 0,51 [.010 - .020]
Finish.....	1,6 (63)
Involute Profile Variation.....	+0,000 -0,025 [+ .0000 - .0010]
Total Index Variation.....	0,038 [.0015]
Lead Variation.....	0,013 [.0005]
Circular Space Width:	
Maximum Actual.....	5,045 [1.986]
Minimum Effective.....	4,995 [1.951]
Maximum Effective.....	Ref. 5,009 [1.972]
Minimum Actual.....	Ref. 4,986 [1.963]
Dimension Between Two Pins.....	Ref. 22,783 - 22,929 [.8970 - .9027]
Pin Diameter.....	5,334 [.2100] Pins to Have 3,73 [.147]

Wide Flat for Root Clearance

4000 Series

Dimensions

Shafts

1 1/4 Inch Straight

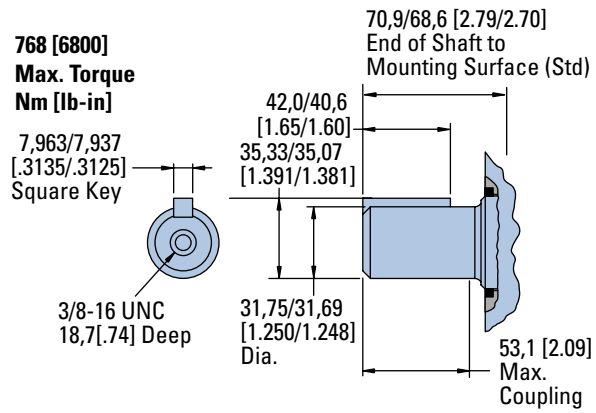

1 1/4 -14 Tooth Splined

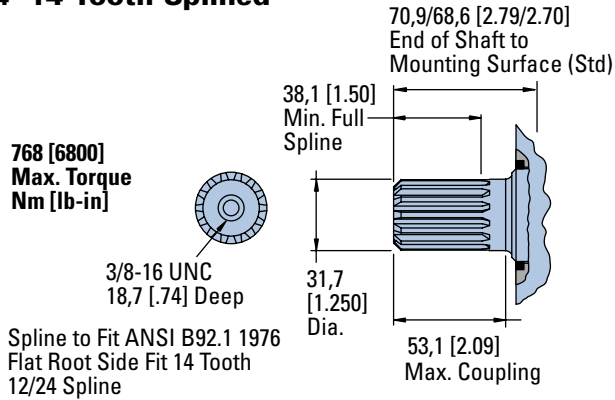

1 5/8 Tapered

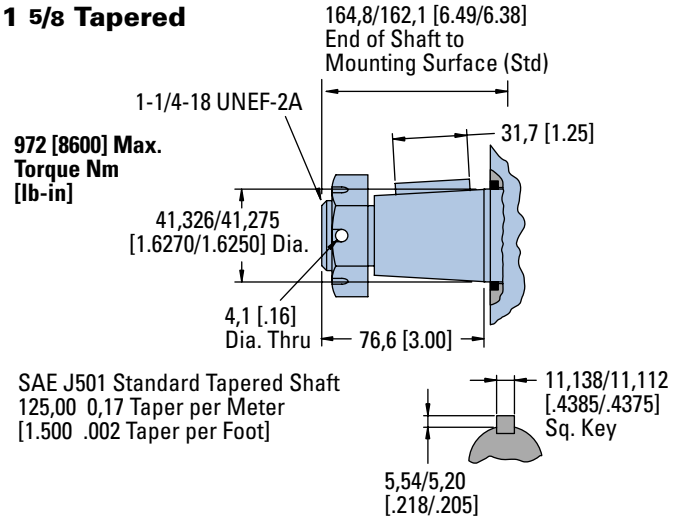

40 mm Straight

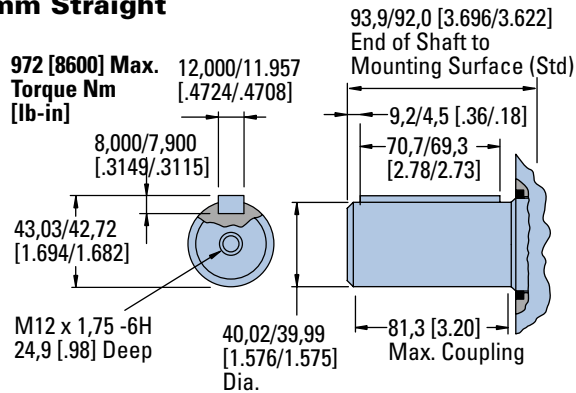

Tapered Shaft Hub Data

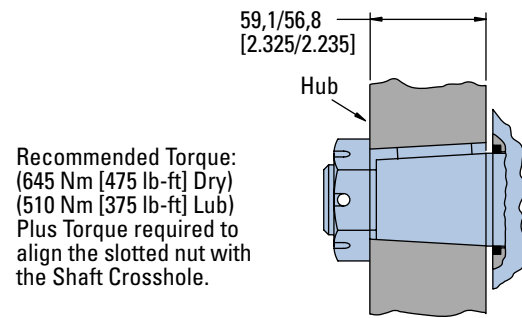

1 1/2 Inch 17-Tooth Splined

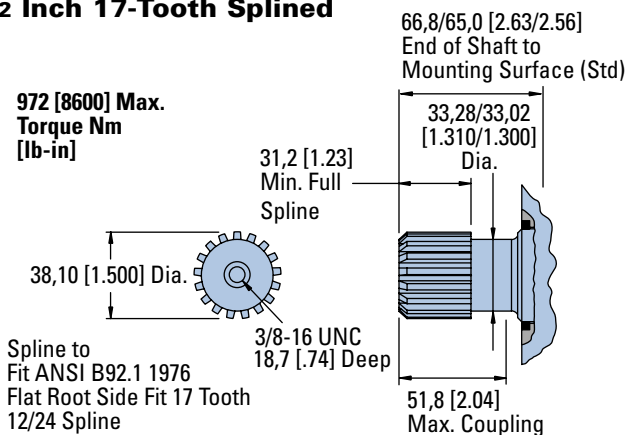

Slotted Hexagon Nut

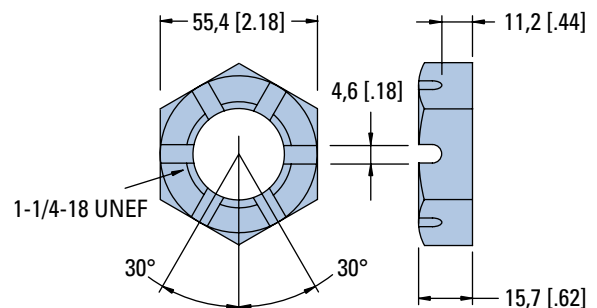

4000 Series

Shaft Side Load Capacity

These curves indicate the radial load capacity on the motor shaft(s) at various locations with an allowable external thrust load of 454 kg [1000 lb].

Note:

Case pressure will increase the allowable Inward thrust load and decrease the allowable outward thrust load. Case pressure will push outward on the shaft at 94 kg/7 Bar [208 lb/100 PSI].

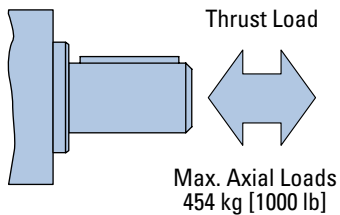

Each curve is based on B 10 bearing life (2000 hours of 12,000,000 shaft revolutions at 100 RPM) at rated output torque.

To determine radial load at speeds other than 100 RPM, multiply the load values given on the bearing curve by the factors in the chart below.

RPM	Multiplication Factor
50	1.23
100	1.00
200	0.81
300	0.72
400	0.66
500	0.62
600	0.58
700	0.56
800	0.54

For 3,000,000 shaft revolutions or 500 hours—Increase these shaft loads 52%.

Standard Motor
Straight and Splined Shafts

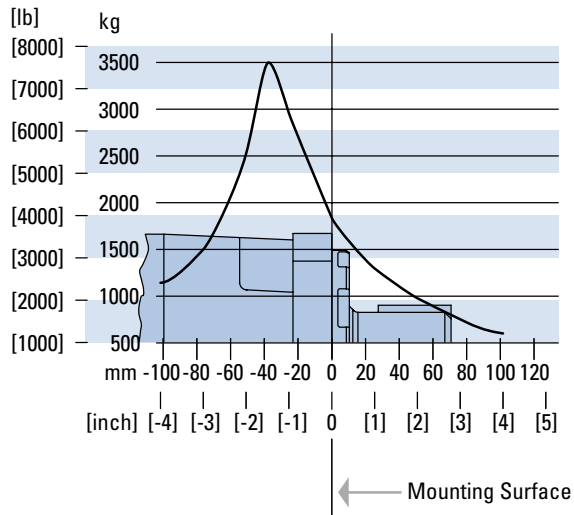

Wheel Motor Tapered Shaft

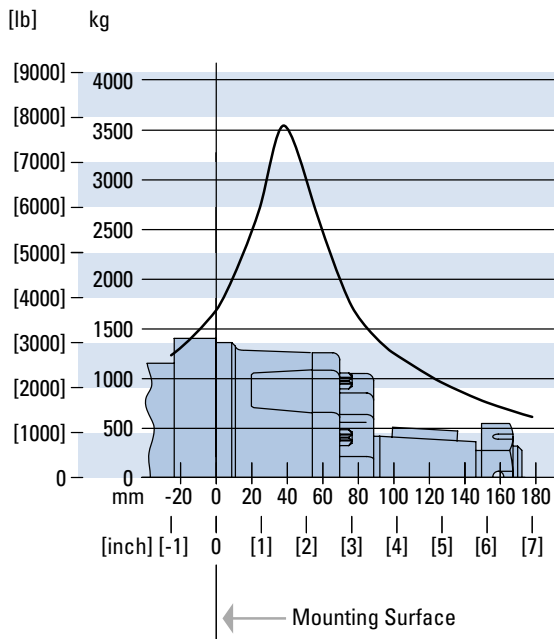

4000 Series

Case Pressure and Case Port

Char-Lynn 4000 Series motors are durable and have long life as long as the recommended case pressure is not exceeded. Allowable case pressure is highest at low shaft speeds. Consequently, motor life will be shortened if case pressure exceeds these ratings (acceptability may vary with application). Determine if an external case drain is required from the case pressure seal limitation chart.

Case Porting Advantage

Contamination Control — flushing the motor case.

Cooler Motor — exiting oil draws motor heat away.

Extend Motor Seal Life — maintain low case pressure with a preset restriction in the case drain line.

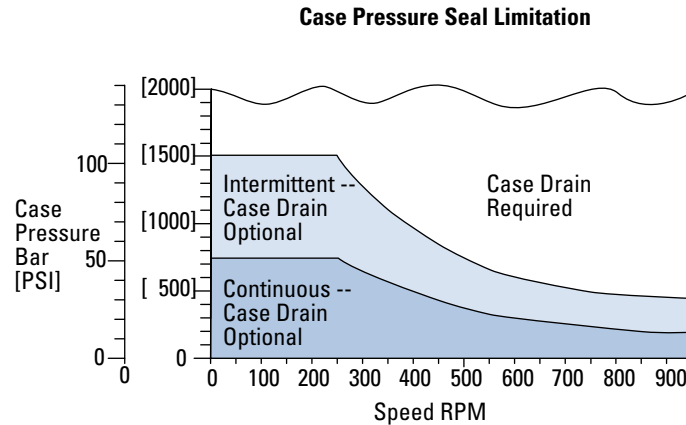

4000 Series

Dimensions

Ports

1-1/16-12 O-ring Ports (2) or G 3/4 (BSP) Ports (2)

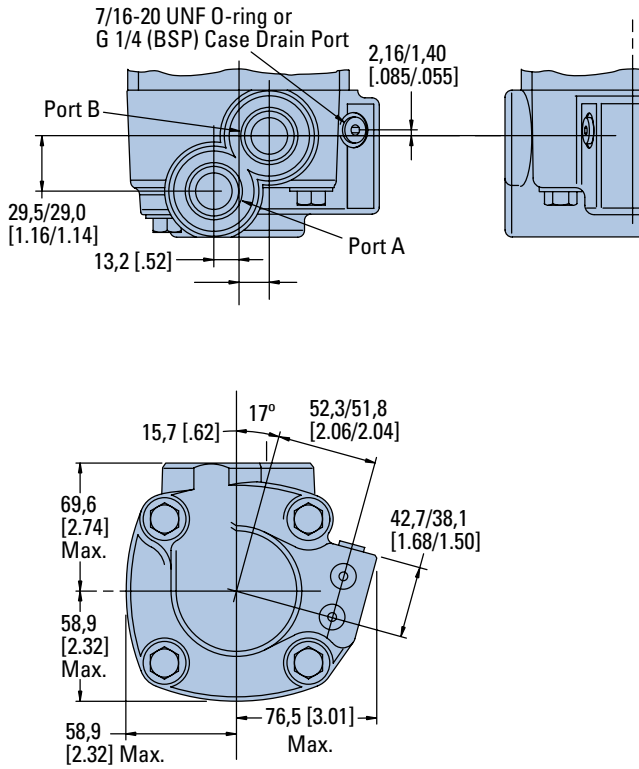

4 Bolt 3/4 Inch Split Flange Ports to Fit SAE J518 c (2)

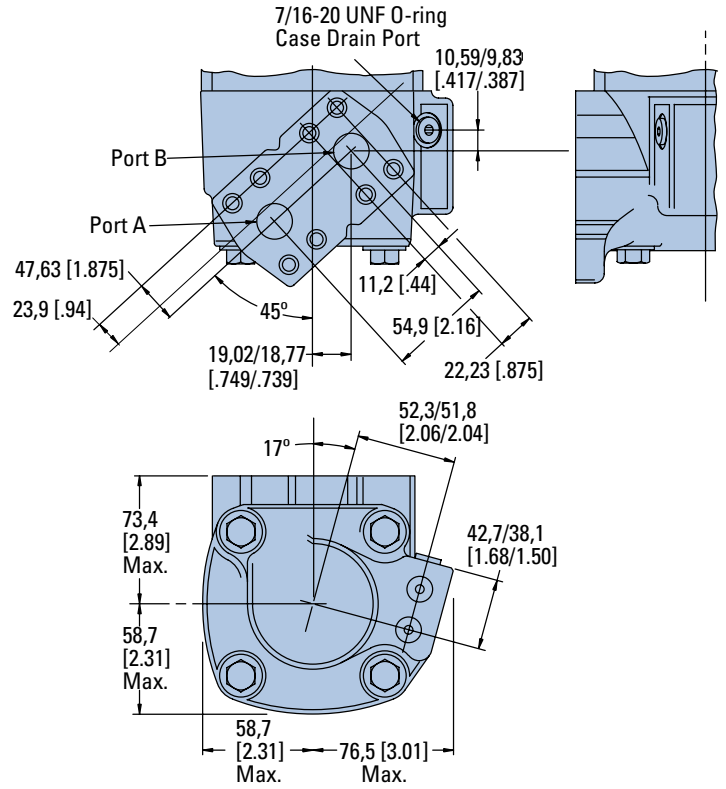

7/8-14 O-ring Ports (2) or M22 x 1,5-6H Ports (2)

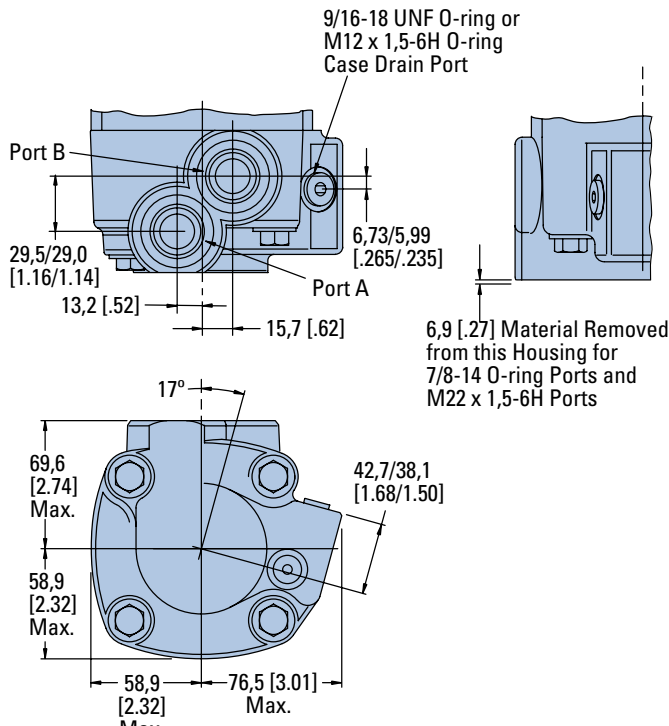

4000 Series

Product Numbers

Note:

For 4000 Series Motors with a configuration **Not Shown** in the charts below: Use model code number system on the next page to specify product in detail.

Use digit prefix —109-, 110-, or 111- plus four digit number from charts for complete product number— Example 111-1057.

Orders will not be accepted without three digit prefix.

MOUNTING	SHAFT	PORT SIZEDISPL. cm ³ /r [in ³ /r] / PRODUCT NUMBER										
		110 [6.7]	130 [7.9]	160 [9.9]	205 [12.5]	245 [15.0]	280* [17.1]	310 [19.0]	395 [24.0]	495 [30.0]	625 [38.0]	
Standard SAE B-Mount	1 1/4 Inch Straight	1 1/16 O-ring	109-1100	-1101	-1102	-1103	-1104	-1094	-1105	-1106	-1212	-1215
		3/4 inch Split Flange	109-1001	-1054	-1002	-1003	-1055	—	-1056	-1057	—	—
	1 5/8 Inch Tapered	1 1/16 O-ring	109-1107	-1108	-1109	-1110	-1111	—	-1112	-1113	-1479	-1455
		3/4 inch Split Flange	109-1006	-1058	-1007	-1008	-1059	—	-1402	-1061	—	—
	1 1/4 Inch 14 T Splined	1 1/16 O-ring	109-1114	-1115	-1116	-1117	-1118	—	-1119	-1120	—	—
		3/4 inch Split Flange	109-1011	-1062	-1012	-1013	-1063	—	-1064	-1065	—	—
Standard SAE C-Mount	40 mm Straight	G 3/4 (BSP)	109-1184	-1185	-1227	-1224	-1225	—	-1189	-1190	—	—
	1 1/4 Inch 17 T Splined	G 3/4 (BSP)	109-1191	-1192	-1193	-1194	-1195	—	-1196	-1197	—	—
Wheel Motor	1 1/4 Inch Straight	1 1/16 O-ring	110-1074	-1075	-1076	-1077	-1078	—	-1079	-1080	—	-1122
		3/4 inch Split Flange	110-1001	-1040	-1002	-1003	-1041	—	-1042	-1043	—	—
	40 mm Straight	G 3/4 (BSP)	110-1108	-1109	-1110	-1111	-1112	—	-1113	-1125	—	—
	1 5/8 Inch Tapered	1 1/16 O-ring	110-1081	-1082	-1083	-1084	-1085	—	-1086	-1087	1116	-1117
		3/4 inch Split Flange	110-1006	-1044	-1007	-1008	-1045	—	-1046	-1047	—	—
	1 1/4 Inch 14 T Splined	1 1/16 O-ring	110-1088	-1089	-1090	-1091	-1092	—	-1093	-1094	—	—
		3/4 inch Split Flange	110-1011	-1048	-1012	-1013	-1049	—	-1050	-1051	—	—
	Bearless	1 1/4 Inch Straight	1 1/16 O-ring	111-1033	-1034	-1035	-1036	-1037	—	-1038	-1039	-1062
3/4 inch Split Flange			111-1044	-1015	-1045	-1046	-1016	—	-1017	-1018	—	—
40 mm Straight		G 3/4 (BSP)	111-1052	-1053	-1054	-1055	-1056	—	-1057	-1058	—	—

* New Release

111-1057

4000 Series

Model Code

The following 14-digit coding system has been developed to identify all of the configuration options for the 4000 Series motor. Use this model code to specify a motor with the desired features. All 14 digits of the code must be present when ordering. You may want to photocopy the matrix below to ensure that each number is entered in the correct box.

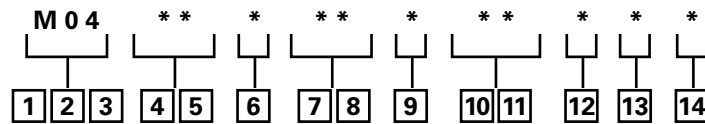

1, 2, 3 Product Series
M04 – 4000 Motor

4, 5 Displacement
cm³/r [in³/r]

- 07** – 110 [6.7]
- 08** – 130 [7.9]
- 10** – 160 [9.9]
- 12** – 205 [12.5]
- 15** – 245 [15.0]
- 17** – 280 [17.1]
- 19** – 310 [19.0]
- 24** – 395 [24.0]
- 30** – 495 [30.0]
- 38** – 625 [38.0]

6 Mounting Type

- A** – 4 Bolt (Bearingless 127,0 [5.00] Pilot Dia. and 14,27 [.562] Dia. Mounting Holes 161,9 [6.38] Dia. B.C.
- B** – 4 Bolt (SAE B) (Standard) 101,6 [4.00] Pilot Dia. and 14,7 [.58] Mounting Slots on 127,0 [5.00] Dia. B.C.
- C** – 4 Bolt (Wheel) 139,7 [5.50] Pilot Dia. and 14,3 [.56] Dia. Mounting Holes on 165,1 [6.50] Dia. B.C.
- F** – 4 Bolt (SAE C) (Standard) 127,0 [5.00] Pilot Dia. and 14,3 [.56] Dia. Mounting Holes on 161,9 [6.38] Dia.

7, 8 Output Shaft

- 00** – None (Bearingless)
- 01** – 1 1/4 inch Dia. Straight with Straight Key, 3/8 -16 Threaded Hole and 53,1 [2.09] Max. Coupling Length
- 02** – 1 5/8 inch Dia. Tapered with Straight Key and 1 1/4 -18 UNEF Slotted Hex. Nut
- 03** – 1 1/4 inch Dia. Splined 14T with 38,1 [1.50] Min. Full Spline Length and 53,1 [2.09] Max. Coupling Length
- 13** – 1 1/2 inch Dia. Splined 17T with 31,2 [1.23] Min. Full Spline Length
- 14** – 40 mm Dia. Straight with Straight Key, M12 x 1,75 - 6H Threaded Hole

9 Ports

- A** – 7/8 -14 O-ring with 9/16-18 O-ring Case Drain with Hot Oil Shuttle Valve
- B** – 1 1/16 - 12 O-ring with 7/16-20 O-ring Case Drain and Check Valve
- C** – G 3/4 (BSP) O-ring with G 1/4 (BSP) O-ring Case Drain and Check Valve
- D** – 3/4 inch 4 Bolt Split Flange with 7/16 -20 O-ring Case Drain and Check Valve
- H** – M22 x 1,5-6H (ISO) O-ring with M12 x 1,5-6H O-ring Case Drain with Hot Oil Shuttle Valve

10, 11 Special Features (Hardware)

- 00** – None
- 01** – Viton Shaft Seal
- 07** – Viton Seals
- 13** – Seal Guard
- 17** – Speed Sensor (Std.)

12 Paint/ Special Packaging

- 0** – No Paint, Individual Box
- A** – Painted Low Gloss Black, Individual Box
- C** – Corrosion Protected

13 Eaton Assigned Code when Applicable

- 0** – Assigned Code

14 Eaton Assigned Design Code

- 0** – Assigned Design Code

Notes

6000 Series

Highlights

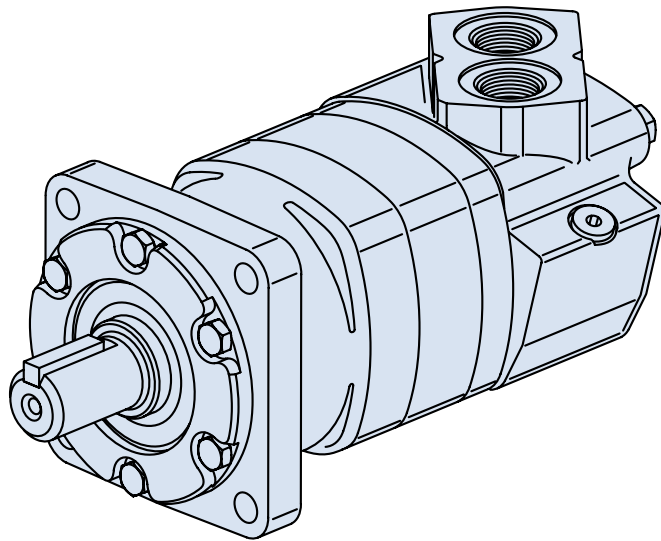

Description

With torque up to 15,000 in-lb and 40 gpm continuous, this motor is packed with power operates very smoothly.

Specifications

Geroler Element	9 Displacements
Flow l/min [GPM]	150 [40] Continuous**
	225 [60] Intermittent*
Speed RPM	775 Cont.**
	866 Inter.*
Pressure bar [PSI]	200 [3000] Cont.**
	300 [4500] Inter.*
Torque Nm [lb-in]	1685 [14920] Cont.**
	1875 [16580] Inter.*

** Continuous — (Cont.) Continuous rating, motor may be run continuously at these ratings.

* Intermittent — (Inter.) Intermittent operation, 10% of every minute.

Features

- 9 displacements available including a 60 CI model.
- Side load up to 4000 lb
- Presents a multitude of options that make this motor very “smart” and flexible to apply

Benefits

- Very tough motor for demanding applications
- Can be used in a multitude of industries
- Very easy/flexible to integrate in a system

Applications

- Mobile equipment
- Snow Removal, mowing
- Spayer, trencher
- Wood products



Mowing



Snow Removal



Sprayer



Trencher

6000 Series Specifications

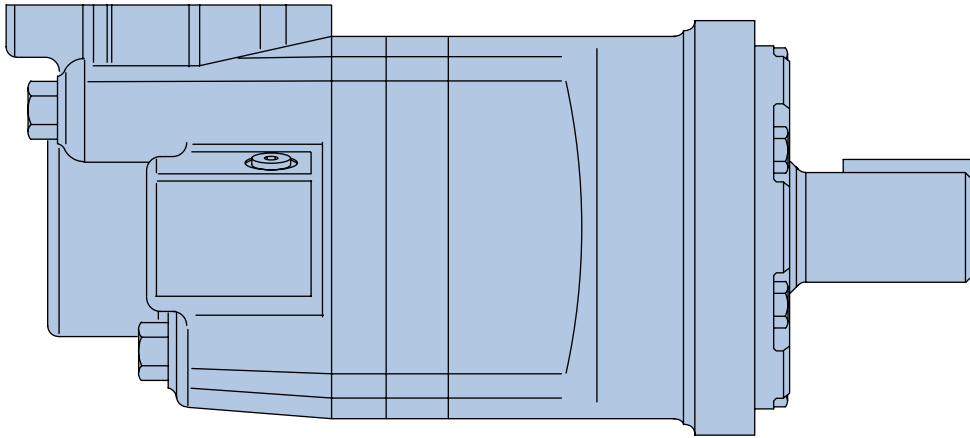

6000 SERIES MOTORS

Displ. cm ³ /r [in ³ /r]		195 [11.9]	245 [15.0]	310 [19.0]	390 [23.9]	490 [30.0]	625 [38.0]	735 [45.0]	805 [49.0]	985 [60.0]
Max. Speed (RPM)	Continuous	775	615	485	387	307	241	203	187	153
	Intermittent	866	834	698	570	454	355	303	280	230
@ Flow										
Flow l/min [GPM]	Continuous	150 [40]	150 [40]	150 [40]	150 [40]	150 [40]	150 [40]	150 [40]	150 [40]	150 [40]
	Intermittent	170 [45]	210 [55]	225 [60]	225 [60]	225 [60]	225 [60]	225 [60]	225 [60]	225 [60]
Torque* Nm [lb-in]	Continuous	575 [5100]	735 [6510]	930 [8230]	1155 [10230]	1445 [12800]	1480 [13100]	1378 [12192]	1582 [14004]	1685 [14920]
	Intermittent	860 [7620]	1100 [9740]	1355 [11990]	1635 [14490]	1885 [16670]	1898 [16800]	1699 [15040]	1850 [16377]	1875 [16580]
Pressure Δ bar [Δ PSI]	Continuous	205 [3000]	205 [3000]	205 [3000]	205 [3000]	205 [3000]	170 [2500]	140 [2000]	140 [2000]	140 [2000]
	Intermittent	310 [4500]	310 [4500]	310 [4500]	310 [4500]	275 [4000]	221 [3200]	170 [2500]	170 [2500]	140 [2000]
	Peak	310 [4500]	310 [4500]	310 [4500]	310 [4500]	310 [4500]	240 [3500]	205 [3000]	170 [2500]	170 [2250]
Weight kg [lb]	Standard or Wheel Mount	24,9 [55.0]	25,2 [55.5]	25,6 [56.5]	26,3 [58.0]	27,0 [59.5]	27,9 [61.5]	28,6 [63.0]	29 [64.0]	30,4 [67.0]
	Bearingless	20,2 [44.5]	20,4 [45.0]	20,9 [46.0]	21,5 [47.5]	22,2 [49.0]	23,1 [51.0]	28,3 [52.5]	28,8 [53.5]	30,2 [56.5]

Maximum Case Pressure: See case pressure seal limitation graph.

*See shaft torque ratings for limitations..

Note:

To assure best motor life, run motor for approximately one hour at 30% of rated pressure before application to full load. Be sure motor is filled with fluid prior to any load applications.

Maximum Inlet Pressure:

310 bar [4500 PSI]
Do not exceed Δ pressure rating (see chart above).

Maximum Return Pressure:

310 bar [4500 PSI] with case drain line installed.
Do not exceed Δ pressure rating (see chart above).

Δ bar [Δ PSI] :

The true pressure difference between inlet port and outlet port

Continuous Rating:

Motor may be run continuously at these ratings

Intermittent Operation:

10% of every minute

Peak Operation:

1% of every minute

Recommended Fluids:

Premium quality, anti-wear type hydraulic oil with a viscosity of not less than 70 SUS at operating temperature.

Recommended Maximum System Operating Temp.:

82° C [180° F]

Recommended Filtration:

per ISO Cleanliness Code, 4406: 20/18/13

6000 Series

Performance Data

Motors run with high efficiency in all areas designated with a number for torque and speed. For best motor life select a motor to run with a torque and speed range shown in the light shaded area.

Performance data is typical at 120 SUS. Actual data may vary slightly from unit to unit in production.

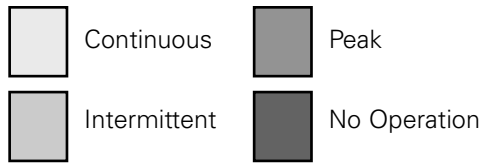

195 cm³/r [11.9 in³/r]
 Δ Pressure Bar [PSI]

	[250] 15	[500] 35	[1000] 70	[1500] 105	[2000] 140	[2500] 170	[3000] 205	[3500] 240	[4000] 275	[4500] 310
[.5] 1,9	[280] 30 9	[650] 75 7	[1450] 165 5	[2290] 260 2						
[2] 7,5	[290] 35 38	[680] 75 37	[1500] 170 35	[2340] 265 34	[3100] 350 30	[3880] 440 26	[4140] 470 18			
[4] 15	[300] 35 77	[710] 80 76	[1500] 175 74	[2390] 270 72	[3210] 365 66	[4030] 455 62	[4600] 520 46	[5200] 590 32	[5790] 655 18	
[8] 30	[310] 35 154	[740] 85 153	[1590] 180 148	[2450] 275 144	[3280] 370 131	[4120] 465 119	[4810] 545 116	[5530] 625 99	[6250] 705 83	[6900] 780 65
[12] 45	[320] 35 232	[750] 85 230	[1610] 180 225	[2480] 280 221	[3330] 375 212	[4190] 475 203	[4990] 565 186	[5810] 655 167	[6630] 750 148	[7320] 825 118
[16] 61	[300] 35 309	[730] 80 307	[1600] 180 303	[2470] 280 300	[3340] 375 291	[4210] 475 283	[5090] 575 258	[5900] 665 236	[6710] 760 214	[7470] 845 181
[20] 76	[270] 30 387	[720] 80 384	[1590] 180 379	[2460] 280 374	[3350] 380 365	[4240] 480 356	[5100] 575 332	[5950] 670 306	[6800] 770 280	[7620] 860 247
[24] 91	[240] 25 465	[700] 80 462	[1570] 175 456	[2440] 275 450	[3330] 375 440	[4220] 475 429	[5080] 575 413	[5940] 670 388	[6810] 770 363	
[28] 106	[190] 20 542	[660] 75 539	[1530] 175 532	[2400] 275 526	[3300] 375 514	[4200] 475 502	[5060] 570 476	[5940] 670 448	[6810] 770 421	
[32] 121	[160] 20 620	[630] 70 617	[1500] 170 609	[2370] 270 602	[3270] 370 589	[4160] 470 576	[5040] 570 542	[5920] 670 511	[6790] 765 480	
[36] 136	[120] 15 697	[620] 70 692	[1480] 165 683	[2350] 265 674	[3240] 365 659	[4130] 465 645	[5000] 565 601	[5880] 665 564	[6760] 765 527	
[40] 151	[80] 10 775	[610] 70 770	[1450] 165 759	[2320] 260 749	[3210] 365 733	[4100] 465 718	[4960] 560 666	[5840] 660 624		
[45] 170		[590] 65 866	[1410] 160 854	[2280] 260 843	[3170] 360 825	[4060] 460 808	[4920] 555 749	[5790] 655 702		

245 cm³/r [15.0 in³/r]
 Δ Pressure Bar [PSI]

	[250] 15	[500] 35	[1000] 70	[1500] 105	[2000] 140	[2500] 170	[3000] 205	[3500] 240	[4000] 275	[4500] 310
[.5] 1,9	[430] 50 7	[860] 95 4	[1890] 215 1							
[2] 7,5	[440] 50 30	[900] 100 29	[1940] 220 26	[2990] 340 24	[3960] 445 21	[4920] 555 17	[5040] 570 11	[5930] 670 6		
[4] 15	[460] 50 61	[940] 105 60	[2000] 225 56	[3060] 345 54	[4080] 460 48	[5090] 575 42	[5680] 640 39	[6630] 750 30	[7570] 855 12	[8520] 965 6
[8] 30	[470] 55 122	[960] 110 120	[2060] 235 116	[3150] 355 113	[4210] 475 104	[5260] 595 95	[6180] 700 81	[7100] 800 67	[8020] 905 53	[9020] 1020 37
[12] 45	[480] 55 183	[970] 110 182	[2080] 235 178	[3180] 360 174	[4270] 480 165	[5360] 605 157	[6390] 720 141	[7420] 840 125	[8450] 955 109	[9510] 1075 92
[16] 61	[450] 50 245	[960] 110 244	[2070] 235 240	[3180] 360 236	[4290] 485 228	[5420] 610 221	[6480] 730 202	[7490] 845 184	[8480] 960 165	[9540] 1180 145
[20] 76	[420] 45 307	[940] 105 306	[2050] 230 301	[3160] 355 297	[4290] 485 287	[5440] 615 277	[6510] 735 257	[7580] 855 238	[8660] 980 218	[9740] 1100 197
[24] 91	[380] 45 368	[920] 105 365	[2020] 230 361	[3120] 355 358	[4260] 480 348	[5400] 610 338	[6490] 735 316	[7590] 860 294	[8680] 980 271	
[28] 106	[330] 35 430	[870] 100 426	[1980] 225 421	[3100] 350 416	[4240] 480 404	[5380] 610 376	[6480] 730 358	[7580] 855 340	[8670] 980 322	
[32] 121	[290] 35 491	[800] 90 489	[1920] 215 481	[3050] 345 475	[4170] 470 461	[5290] 600 448	[6410] 725 423	[7520] 850 398	[8640] 975 373	
[36] 136	[250] 30 556	[730] 80 549	[1850] 210 543	[2980] 335 537	[4060] 460 524	[5150] 580 509	[6300] 710 482	[7440] 840 456		
[40] 151	[200] 25 615	[690] 80 612	[1790] 200 606	[2940] 330 599	[4010] 455 585	[5130] 580 570	[6190] 700 540	[7100] 800 510		
[45] 170		[570] 65 688	[1760] 200 682	[2860] 325 674	[3960] 445 658	[5070] 575 641	[6080] 685 608	[6690] 755 574		
[50] 189			[1720] 195 758	[2800] 315 749	[3890] 440 731	[4920] 555 712	[5940] 670 676			
[55] 208			[1670] 190 834	[2740] 310 824	[3820] 430 804	[4890] 550 783	[5880] 665 744			

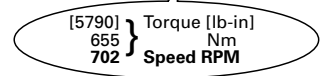

6000 Series

Performance Data

Motors run with high efficiency in all areas designated with a number for torque and speed. For best motor life select a motor to run with a torque and speed range shown in the light shaded area.

Performance data is typical at 120 SUS. Actual data may vary slightly from unit to unit in production.

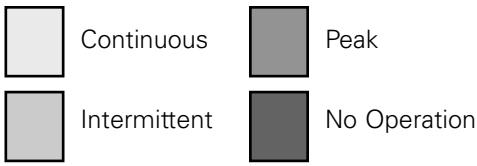

310 cm³/r [19.0 in³/r]
 Δ Pressure Bar [PSI]

	[250] 15	[500] 35	[1000] 70	[1500] 105	[2000] 140	[2500] 170	[3000] 205	[3500] 240	[4000] 275	[4500] 310
[.5] 1.9	[530] 60 6	[1120] 125 4	[2440] 275 1							
[2] 7.5	[540] 60 24	[1150] 130 23	[2460] 280 22	[3620] 410 20	[4780] 540 17	[5690] 645 14	[6670] 755 10	[7780] 880 4		
[4] 15	[550] 60 48	[1180] 135 47	[2560] 290 45	[3800] 430 42	[5030] 570 38	[6050] 685 32	[7070] 800 24	[8260] 935 17	[9070] 1025 10	[9530] 1075 3
[8] 30	[560] 65 96	[1250] 140 95	[2650] 300 91	[3970] 450 87	[5280] 595 81	[6480] 730 73	[7710] 870 64	[8740] 985 55	[9770] 1105 46	[10990] 1240 35
[12] 45	[570] 65 144	[1260] 140 143	[2690] 305 140	[4050] 460 135	[5420] 610 129	[6730] 760 121	[8040] 910 111	[9260] 1045 99	[10490] 1185 88	[11800] 1335 76
[16] 61	[540] 60 193	[1230] 140 192	[2660] 300 188	[4060] 460 184	[5450] 615 178	[6800] 770 167	[8150] 920 156	[9400] 1060 141	[10660] 1205 126	[11990] 1355 109
[20] 76	[510] 60 242	[1200] 135 241	[2630] 295 236	[4040] 455 232	[5450] 615 226	[6820] 770 216	[8190] 925 201	[9520] 1075 184	[10840] 1225 167	
[24] 91	[480] 55 290	[1160] 130 289	[260] 295 282	[4020] 455 279	[5440] 615 273	[6840] 775 260	[8230] 930 248	[9560] 1080 232	[10900] 1230 215	
[28] 106	[420] 45 339	[1130] 130 336	[2570] 290 333	[3990] 450 328	[5420] 610 320	[6820] 770 308	[8220] 930 295	[9520] 1075 276	[10840] 1225 257	
[32] 121	[360] 40 388	[1100] 125 384	[2510] 285 381	[3920] 445 375	[5330] 600 368	[6750] 765 354	[8170] 920 341	[9440] 1065 320		
[36] 136	[300] 35 436	[1060] 120 430	[2440] 275 421	[3830] 435 416	[5220] 590 410	[6660] 750 396	[8100] 915 383	[9330] 1055 360		
[40] 151	[270] 30 485	[1020] 115 478	[2400] 270 466	[3780] 425 461	[5150] 580 456	[6580] 745 441	[8020] 905 427	[9220] 1040 403		
[50] 189		[982] 110 597	[2180] 245 582	[3420] 385 576	[4660] 525 570	[6050] 685 551	[7440] 840 534			
[60] 227			[1960] 220 698	[3250] 365 691	[4540] 515 684	[5750] 650 661	[7080] 800 641			

390 cm³/r [23.9 in³/r]
 Δ Pressure Bar [PSI]

	[250] 15	[500] 35	[1000] 70	[1500] 105	[2000] 140	[2500] 170	[3000] 205	[3500] 240	[4000] 275	[4500] 310
[1] 3.8	[760] 85 4	[1570] 175 2	[3230] 365 1							
[2] 7.5	[780] 90 19	[1610] 180 18	[3270] 370 17	[4910] 555 16	[6440] 730 14	[7760] 875 12	[9080] 1025 9	[10590] 1195 4		
[4] 15	[800] 90 38	[1640] 185 38	[3300] 375 37	[4970] 560 35	[6570] 740 33	[8160] 920 29	[9570] 1080 22	[11270] 1275 14	[12120] 1370 5	[14490] 1635 1
[8] 30	[810] 90 77	[1650] 185 76	[3370] 380 74	[5080] 575 72	[6740] 760 68	[8430] 950 65	[10050] 1135 55	[11620] 1315 45	[12880] 1455 33	[14480] 1635 21
[12] 45	[800] 90 115	[1620] 185 115	[3390] 385 112	[5130] 580 109	[6810] 770 105	[8520] 965 100	[10190] 1150 91	[11860] 1340 81	[13640] 1540 79	
[16] 61	[750] 85 154	[1600] 180 154	[3380] 380 151	[5120] 580 147	[6820] 770 143	[8560] 965 132	[10230] 1155 126	[11920] 1345 116		
[20] 76	[680] 75 193	[1580] 180 193	[3360] 380 189	[5120] 580 187	[6840] 775 182	[8590] 970 175	[10280] 1160 162	[11980] 1355 152		
[24] 91	[620] 70 232	[1520] 170 230	[3280] 370 229	[5060] 570 225	[6780] 765 220	[8530] 965 212	[10240] 1155 204			
[28] 106	[570] 65 270	[1460] 165 268	[3210] 365 266	[5000] 565 261	[6730] 760 256	[8480] 960 248	[10200] 1150 236			
[32] 121	[530] 60 309	[1420] 160 306	[3140] 355 304	[4930] 555 299	[6640] 750 292	[8380] 945 282	[10120] 1145 269			
[36] 136	[450] 50 348	[1370] 155 346	[3010] 340 340	[4840] 545 336	[6500] 730 329	[8250] 930 317	[10000] 1130 301			
[40] 151	[380] 45 387	[1320] 150 386	[2880] 325 380	[4740] 535 375	[6460] 730 368	[8120] 915 359				
[50] 189		[1140] 130 482	[2650] 300 475	[4540] 515 469	[6440] 730 460	[8050] 910 449				
[60] 227			[2460] 280 570	[4430] 500 562	[6360] 720 552	[7860] 890 538				

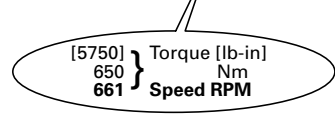

6000 Series

Performance Data

Motors run with high efficiency in all areas designated with a number for torque and speed. For best motor life select a motor to run with a torque and speed range shown in the light shaded area.

Performance data is typical at 120 SUS. Actual data may vary slightly from unit to unit in production.

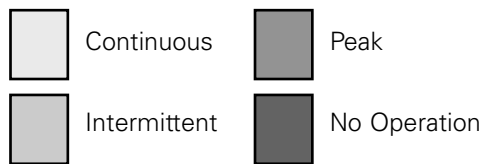

490 cm³/r [30.0 in³/r]
 Δ Pressure Bar [PSI]

	[250] 15	[500] 35	[1000] 70	[1500] 105	[2000] 140	[2500] 170	[3000] 205	[3500] 240	[4000] 275
[1] 3,8	[1010] 115 7	[1200] 235 7	[4260] 480 5	[6140] 695 3					
[2] 7,5	[1020] 115 15	[2110] 240 14	[4270] 480 13	[6280] 710 12	[8350] 945 11	[10420] 1175 8	[12140] 1370 3		
[4] 15	[1030] 115 30	[2100] 235 30	[4280] 485 29	[6410] 725 28	[8500] 960 27	[10590] 1195 25	[12500] 1410 21	[14580] 1645 17	[16670] 1885 12
[8] 30	[1020] 115 60	[2090] 235 60	[4290] 485 59	[6490] 735 57	[8620] 975 54	[10740] 1215 51	[12800] 1445 45	[14930] 1685 38	
[12] 45	[1000] 115 91	[2080] 235 91	[4290] 485 89	[6500] 735 87	[8650] 975 84	[10800] 1220 79	[12890] 1455 71		
[16] 61	[110] 960 122	[2060] 235 122	[4260] 480 121	[6480] 730 118	[8650] 975 114	[10820] 1220 109	[12900] 1460 100		
[20] 76	[900] 100 153	[1980] 225 152	[4180] 470 150	[6420] 725 147	[8620] 975 144	[10820] 1220 139			
[24] 91	[850] 95 184	[1930] 220 184	[4150] 470 181	[6390] 720 180	[8580] 970 176	[10770] 1215 171			
[28] 106	[740] 85 215	[1840] 210 214	[4070] 460 211	[6290] 710 208	[8500] 960 204	[10720] 1210 198			
[32] 121	[690] 80 245	[1710] 195 244	[3970] 450 241	[6190] 700 237	[8420] 950 232	[10660] 1205 226			
[36] 136	[670] 75 276	[1560] 175 275	[3860] 435 272	[6080] 685 265	[8340] 940 260	[10420] 1175 255			
[40] 151	[570] 65 307	[1400] 160 306	[3750] 425 303	[5970] 675 295	[8140] 920 290	[10180] 1150 284			
[50] 189		[1140] 130 382	[3240] 365 379	[5220] 590 369	[7620] 860 362				
[60] 227			[2860] 325 454	[4860] 550 442	[7140] 805 435				

Flow LPM [GPM]

625 cm³/r [38.0 in³/r]
 Δ Pressure Bar [PSI]

	[250] 15	[500] 35	[1000] 70	[1500] 105	[2000] 140	[2500] 170	[3000] 205	[3200] 221
[1] 3,8	[1060] 120 5	[2205] 250 5	[4515] 510 4	[6690] 755 2				
[2] 7,5	[1090] 125 12	[2300] 260 12	[4720] 535 13	[7025] 795 10	[9360] 1060 6			
[4] 15	[1145] 130 24	[2450] 275 24	[5052] 570 24	[7520] 850 21	[9410] 1065 16	[12700] 1434 13		
[8] 30	[1195] 135 45	[2600] 295 45	[5350] 605 44	[8195] 925 42	[11220] 1270 37	[13100] 1480 35	[15800] 1785 32	[16800] 1898 30
[12] 45	[1200] 135 72	[2600] 295 72	[5390] 610 71	[8145] 920 68	[11770] 1330 64	[13000] 1469 60	[15700] 1774 56	
[16] 61	[1120] 125 94	[2530] 285 94	[5340] 605 92	[8105] 915 89	[11740] 1325 85	[13000] 1469 83		
[20] 76	[1050] 120 120	[2465] 280 119	[5285] 595 117	[8080] 915 115	[11725] 1325 110			
[24] 91	[950] 105 144	[2365] 265 143	[5180] 585 140	[7990] 905 138	[11705] 1320 132			
[28] 106	[855] 95 169	[2255] 255 168	[5080] 575 165	[7915] 895 162	[11640] 1315 156			
[32] 121	[730] 80 193	[2140] 240 192	[4960] 560 188	[7775] 880 185	[11505] 1300 179			
[36] 136	[555] 65 217	[1965] 220 216	[4780] 540 213	[7585] 855 210				
[40] 151	[380] 45 241	[1790] 200 240	[4600] 520 238	[7395] 835 236				
[50] 189			[4180] 470 296	[6985] 790 290				
[60] 227			[3800] 430 353	[6600] 745 345				

Flow LPM [GPM]

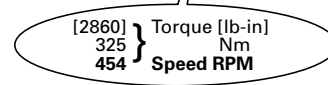

6000 Series

Performance Data

Motors run with high efficiency in all areas designated with a number for torque and speed. For best motor life select a motor to run with a torque and speed range shown in the light shaded area.

Performance data is typical at 120 SUS. Actual data may vary slightly from unit to unit in production.

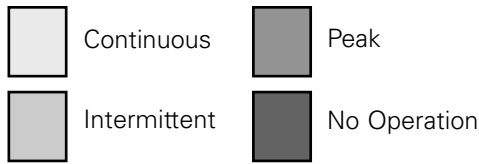

735 cm³/r [45.0 in³/r]
 Δ Pressure Bar [PSI]

	[250] 15	[500] 35	[750] 50	[1000] 70	[1250] 85	[1500] 105	[1750] 120	[2000] 140	[2250] 155	[2500] 170
[1] 3,8	[1311] 148 4	[2775] 314 4	[4200] 475 3	[5480] 619 3	[7000] 791 2					
[2] 7,5	[1340] 151 10	[2856] 323 10	[4535] 512 10	[5809] 656 10	[7551] 853 9	[8685] 981 7	[10182] 1150 6	[11121] 1257 5		
[4] 15	[1253] 142 20	[2854] 322 20	[4363] 493 19	[5813] 657 18	[7272] 822 17	[8714] 985 16	[10135] 1145 14	[11537] 1303 13	[12970] 1465 11	[15040] 1699 11
[8] 30	[1290] 146 40	[2889] 326 39	[4540] 513 38	[6130] 693 38	[7703] 870 37	[9202] 1040 37	[10666] 1205 35	[12192] 1378 33	[13713] 1549 32	
[12] 45	[1277] 144 61	[2821] 319 60	[4528] 512 59	[6180] 698 58	[7795] 881 57	[9338] 1055 56	[10877] 1229 54	[12419] 1403 52		
[16] 61	[1196] 135 82	[2753] 311 80	[4478] 506 79	[6148] 695 78	[7768] 878 77	[9376] 1059 76	[10984] 1241 74			
[20] 76	[1092] 123 102	[2794] 316 101	[4320] 488 101	[6021] 680 99	[7697] 870 97	[9311] 1052 96	[10907] 1232 93			
[24] 91	[1206] 136 123	[2556] 289 122	[4162] 470 120	[5871] 663 119	[7564] 855 118	[9289] 1049 116				
[28] 106	[1083] 122 145	[2338] 264 142	[4040] 456 141	[5666] 640 139	[7365] 832 137	[9022] 1019 135				
[32] 121	[950] 107 163	[2110] 238 162	[3795] 429 162	[5457] 617 159	[7122] 805 159	[8828] 997 156				
[36] 136	[726] 82 184	[1845] 208 183	[3517] 397 182	[5223] 590 181	[6853] 774 179					
[40] 151	[515] 58 203	[2227] 252 202	[3270] 369 202	[4965] 561 201	[6672] 754 199					
[50] 189			[3869] 437 254	[4148] 469 252	[5850] 661 250					
[60] 227				[4856] 549 303	[6604] 746 301					

805 cm³/r [49.0 in³/r]
 Δ Pressure Bar [PSI]



	[250] 15	[500] 35	[750] 50	[1000] 70	[1250] 85	[1500] 105	[1750] 120	[2000] 140	[2250] 155	[2500] 170
[1] 3,8	[1455] 164 4	[3100] 350 4	[4680] 529 2	[6031] 681 2	[7799] 881 1					
[2] 7,5	[1483] 168 9	[3173] 359 9	[5121] 579 9	[6432] 727 8	[8510] 961 7	[9633] 1088 6	[11319] 1279 5	[12127] 1370 5		
[4] 15	[1547] 175 19	[3331] 376 19	[5292] 598 18	[6744] 762 17	[8714] 984 16	[10075] 1138 15	[11352] 1283 14	[12539] 1417 12	[14564] 1645 11	[16377] 1850 10
[8] 30	[1599] 181 35	[3473] 392 35	[5415] 612 34	[7039] 795 33	[8934] 1009 32	[10629] 1201 31	[11842] 1338 29	[14004] 1582 29	[15441] 1745 28	
[12] 45	[1599] 181 56	[3469] 392 56	[5415] 612 55	[7093] 801 53	[9024] 1020 53	[10658] 1204 52	[12283] 1388 50	[13726] 1551 50		
[16] 61	[1543] 174 73	[3395] 384 73	[5357] 605 72	[7032] 794 70	[8983] 1015 69	[10640] 1202 68	[12010] 1357 67			
[20] 76	[1457] 165 93	[3312] 374 92	[5292] 598 91	[6968] 787 89	[8943] 1010 88	[10583] 1196 87	[12146] 1372 86			
[24] 91	[1352] 153 112	[3183] 360 112	[5088] 575 111	[6811] 769 110	[8812] 996 108	[10411] 1176 106				
[28] 106	[1213] 137 131	[3055] 345 131	[5047] 570 131	[6713] 758 129	[8681] 981 128	[10411] 1176 127				
[32] 121	[1075] 121 150	[2907] 328 149	[4884] 552 149	[6546] 740 146	[8395] 949 145	[10060] 1137 144				
[36] 136	[823] 93 168	[2692] 304 168	[4663] 527 168	[6320] 714 167	[8118] 917 165					
[40] 151	[592] 67 187	[2477] 280 186	[4426] 500 186	[6085] 688 185	[7832] 885 184					
[50] 189		[2730] 308 234	[4214] 476 233	[5849] 661 231	[7603] 859 230					
[60] 227			[3806] 430 280	[5459] 617 277	[7407] 837 275					





6000 Series

Performance Data

985 cm³/r [60.0 in³/r]
D Pressure Bar [PSI]

Motors run with high efficiency in all areas designated with a number for torque and speed. For best motor life select a motor to run with a torque and speed range shown in the light shaded area.

Performance data is typical at 120 SUS. Actual data may vary slightly from unit to unit in production.

	Continuous		Peak
	Intermittent		No Operation

	[250] 15	[500] 35	[750] 50	[1000] 70	[1250] 85	[1500] 105	[1750] 120	[2000] 140
[1] 3,8	[1890] 215 3	[4110] 465 3	[5730] 645 2	[7640] 865 2	[9550] 1080 1			
[2] 7,5	[1910] 215 8	[4140] 470 8	[6270] 710 7	[8300] 940 7	[10420] 1175 6	[12500] 1410 5	[13860] 1565 4	[14920] 1685 3
[4] 15	[1980] 225 15	[4290] 485 15	[6480] 775 15	[8540] 965 14	[10670] 1205 14	[12800] 1445 13	[13900] 1570 13	[15850] 1790 12
[8] 30	[2030] 230 30	[4400] 495 30	[6630] 750 30	[8790] 995 29	[10940] 1235 28	[13090] 1480 27	[14500] 1640 26	[16580] 1875 25
[12] 45	[2020] 230 45	[4390] 495 45	[6630] 750 45	[8860] 1000 44	[11050] 1250 43	[13240] 1495 42	[15040] 1700 41	
[16] 61	[2010] 225 61	[4320] 490 61	[6560] 740 61	[8790] 995 60	[11000] 1245 59	[13260] 1500 58		
[20] 76	[1910] 215 77	[4220] 475 77	[6480] 730 76	[8720] 985 76	[10950] 1235 75	[13160] 1485 74		
[24] 91	[1810] 205 92	[4060] 460 92	[6230] 705 92	[8500] 960 91	[10790] 1220 90	[12990] 1470 89		
[28] 106	[1620] 185 107	[3920] 445 107	[6180] 700 107	[8420] 950 106	[10630] 1200 105	[12820] 1450 103		
[32] 121	[1480] 165 123	[3740] 425 123	[5980] 675 122	[8200] 925 121	[10280] 1160 120			
[36] 136	[1140] 130 138	[3490] 395 138	[5710] 645 138	[7930] 895 137	[9940] 1125 135			
[40] 151	[850] 95 153	[3240] 365 153	[5420] 610 152	[7640] 865 151	[9590] 1085 150			
[50] 189		[2960] 325 191	[5160] 585 190	[7350] 830 189	[9310] 1050 188			
[60] 227			[4660] 525 230	[7160] 810 229	[9070] 1025 226			

[7160]
810
229 } Torque [lb-in]
Nm
Speed RPM

6000 Series

Dimensions

Ports

- 1 5/16 -12 UN-2B SAE O-ring Staggered Ports (2)
- 7/16 -20 UNF-2B SAE O-ring Case Drain Port (1) or
- 4 Bolt 3/4 inch Split Flange Ports (2)
- 7/16 -20 UNF-2B SAE O-ring Case Drain Port (1) or
- G 1 (BSP) Staggered Ports (2)
- G 1/4 (BSP) Case Drain Port (1) or
- 1 5/16 UN-2B SAE O-ring Staggered Ports (2) with Shuttle
- 9/16 -20 UNF-2B SAE O-ring Case Drain Port (1)

Standard Rotation Viewed from Shaft End

- Port A Pressurized — CW
- Port B Pressurized — CCW

Standard Mount

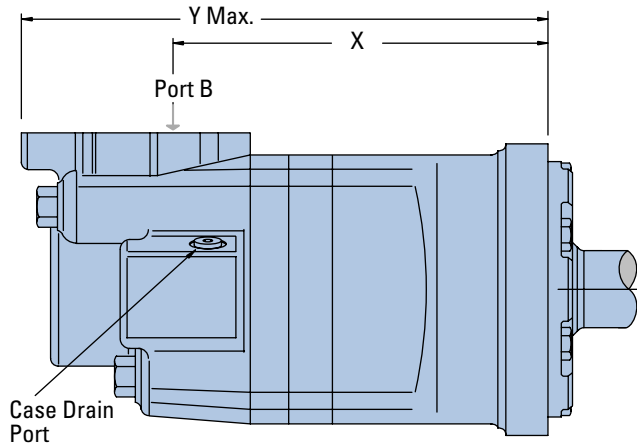

Standard SAE CC Flange

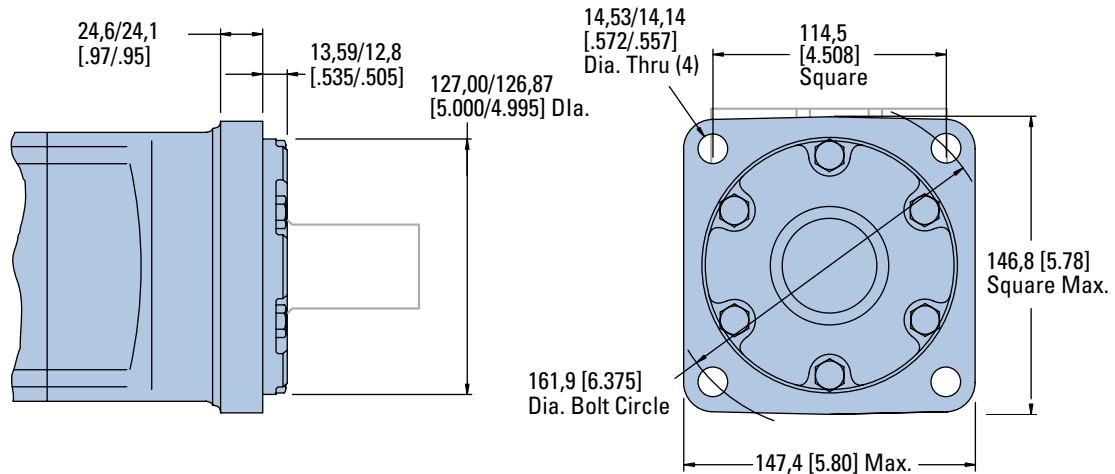

STANDARD MOTOR MOUNT DIMENSIONS

Displacement cm ³ /r [in ³ /r]	X mm [inch]	Y mm [inch]
195 [11.9]	187,5 [7.38]	270,0 [10.63]
245 [15.0]	193,0 [7.60]	275,6 [10.85]
310 [19.0]	200,4 [7.89]	283,0 [11.14]
390 [23.9]	209,0 [8.23]	291,6 [11.48]
490 [30.0]	220,2 [8.67]	302,8 [11.92]
625 [38.0]	235,0 [9.25]	317,5 [12.50]
985 [60.0]	274,6 [10.81]	357,1 [14.06]

6000 Series

Dimensions

Ports

- 1 5/16 -12 UN-2B SAE O-ring Staggered Ports (2)
- 7/16 -20 UNF-2B SAE O-ring Case Drain Port (1) or
- 4 Bolt 3/4 inch Split Flange Ports (2)
- 7/16 -20 UNF-2B SAE O-ring Case Drain Port (1) or
- G 1 (BSP) Staggered Ports (2)
- G 1/4 (BSP) Case Drain Port (1) or
- 1 5/16 UN-2B SAE O-ring Staggered Ports (2) with Shuttle
- 9/16 -20 UNF-2B SAE O-ring Case Drain Port (1)

Standard Rotation Viewed from Shaft End

- Port A Pressurized — CW
- Port B Pressurized — CCW

Wheel Mount

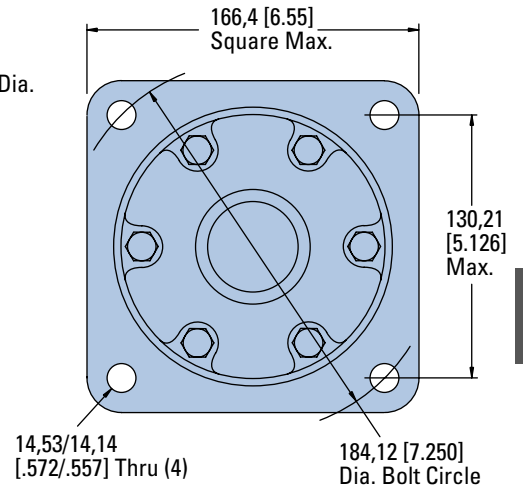
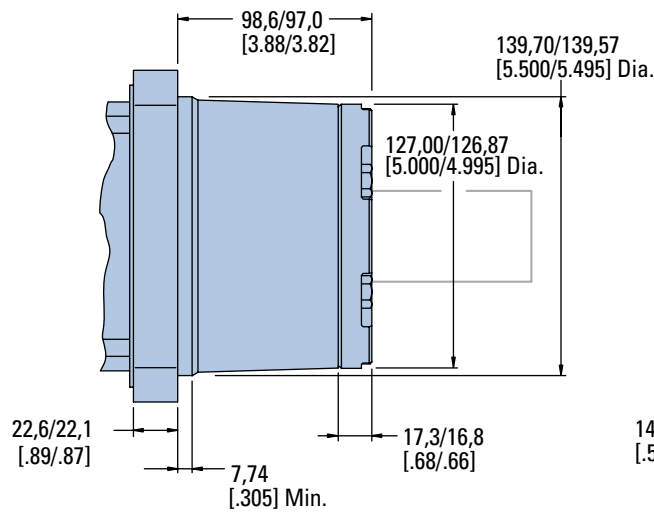
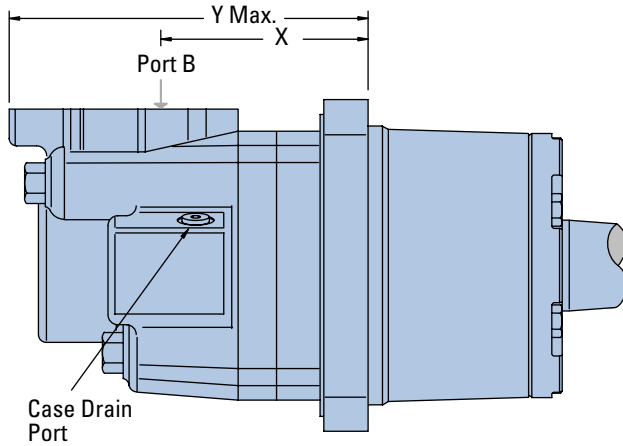

WHEEL MOUNT MOTOR DIMENSIONS

Displacement cm ³ /r [in ³ /r]	X mm [inch]	Y mm [inch]
195 [11.9]	102,6 [4.04]	185,2 [7.29]
245 [15.0]	108,2 [4.26]	190,8 [7.51]
310 [19.0]	115,6 [4.55]	198,1 [7.80]
390 [23.9]	124,5 [4.90]	207,1 [8.15]
490 [30.0]	135,4 [5.33]	217,9 [8.58]
625 [38.0]	150,1 [5.91]	232,7 [9.16]
985 [60.0]	189,7 [7.47]	272,5 [10.73]

6000 Series

Dimensions

Ports

- 1 5/16 -12 UN-2B SAE O-ring Staggered Ports (2)
- 7/16 -20 UNF-2B SAE O-ring Case Drain Port (1) or
- 4 Bolt 3/4 inch Split Flange Ports (2)
- 7/16 -20 UNF-2B SAE O-ring Case Drain Port (1) or
- G 1 (BSP) Staggered Ports (2)
- G 1/4 (BSP) Case Drain Port (1) or
- 1 5/16 UN-2B SAE O-ring Staggered Ports (2) with Shuttle
- 9/16 -20 UNF-2B SAE O-ring Case Drain Port (1)

Standard Rotation Viewed from Shaft End

- Port A Pressurized — CW
- Port B Pressurized — CCW

Global Mount (ISO)

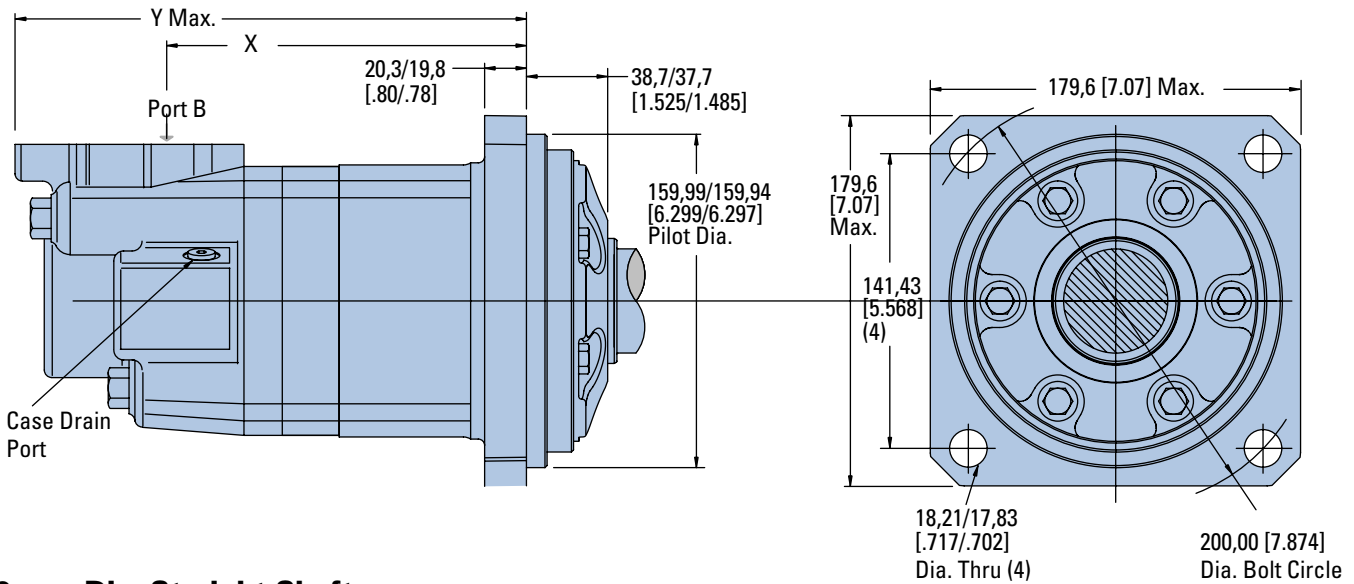

50 mm Dia. Straight Shaft

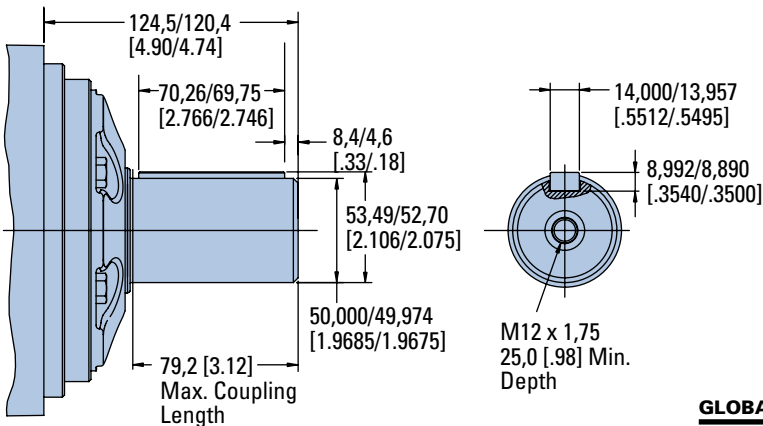

GLOBAL MOUNT MOTOR DIMENSIONS

Displacement cm ³ /r [in ³ /r]	X mm [inch]	Y mm [inch]
310 [19.0]	182,4 [7.18]	264,9 [10.43]
390 [24.0]	191,0 [7.52]	273,6 [10.77]
490 [30.0]	202,2 [7.96]	284,7 [11.21]
625 [38.0]	216,9 [8.54]	299,5 [11.79]
800 [45.0]	229,4 [9.03]	312,2 [12.29]
800 [49.0]	236,7 [9.32]	319,3 [12.57]
985 [60.0]	256,5 [10.10]	339,1 [13.35]

6000 Series

Dimensions

Bearingless

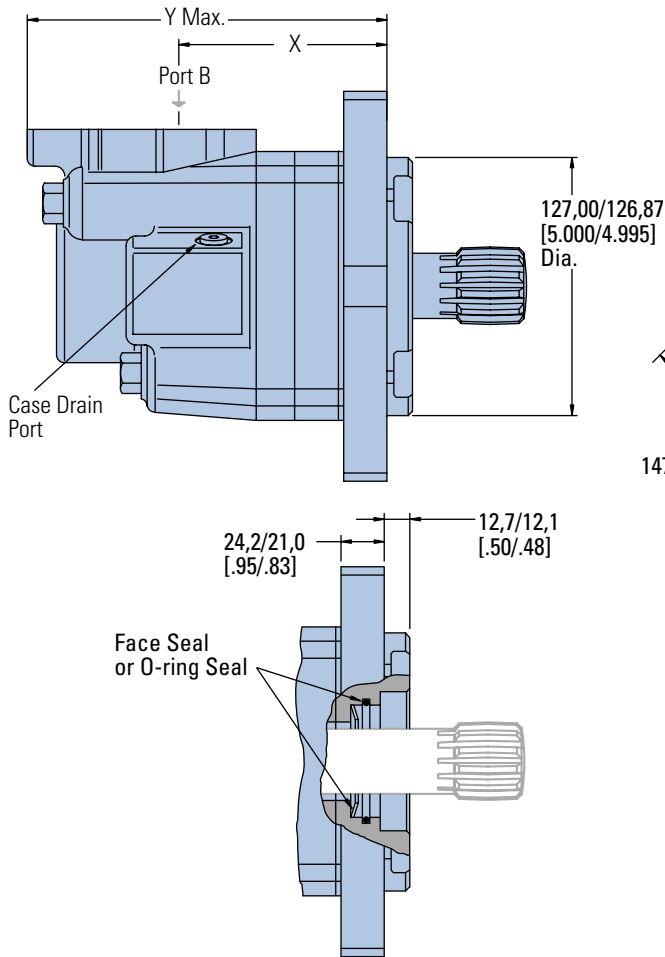

Ports

- 1 5/16 -12 UN-2B SAE O-ring Staggered Ports (2)
- 7/16 -20 UNF-2B SAE O-ring Case Drain Port (1) or
- 4 Bolt 3/4 inch Split Flange Ports (2)
- 7/16 -20 UNF-2B SAE O-ring Case Drain Port (1) or
- G 1 (BSP) Staggered Ports (2)
- G 1/4 (BSP) Case Drain Port (1) or
- 1 5/16 UN-2B SAE O-ring Staggered Ports (2) with Shuttle
- 9/16 -20 UNF-2B SAE O-ring Case Drain Port (1)

Standard Rotation Viewed from Shaft End

- Port A Pressurized — CW
- Port B Pressurized — CCW

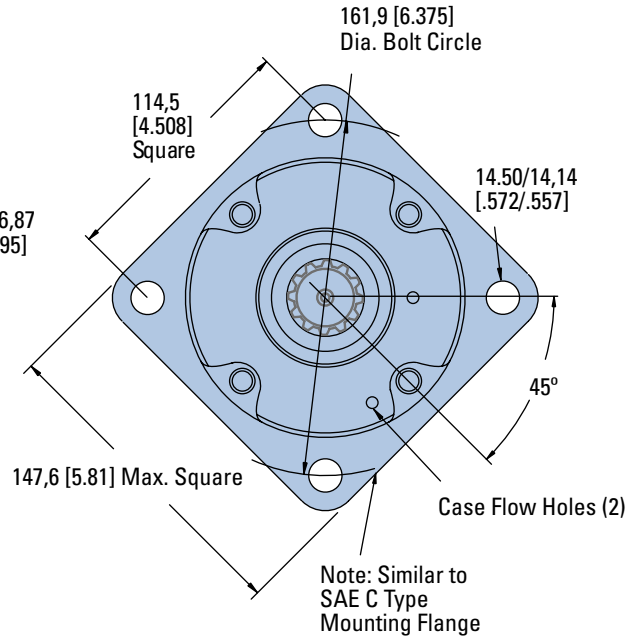

For 6000 bearingless motor application information, contact your Eaton representative (mating coupling blanks available from Eaton Hydraulics).

Note:

After machining blank, part must be hardened per Eaton specification.

- C 47,2 [1.86] Dia.
- D 111,5 [4.39] Max.
- E 106,4 [4.19] Full Form Dia.
- F 6,9 [.27] Min. Full Form Dia.
- G 10,2 [.40] Min.
- H 86,1 [3.39] Max.
- J 66,5 [2.62] Dia.

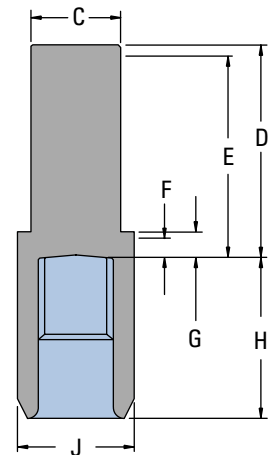

Mating Coupling Blank
Eaton Part No. 12778-002

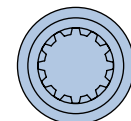

BEARINGLESS MOTOR DIMENSIONS

Displacement cm ³ /r [in ³ /r]	X mm [inch]	Y mm [inch]
195 [11.9]	105,4 [4.15]	188,0 [7.40]
245 [15.0]	111,0 [4.37]	193,5 [7.62]
310 [19.0]	118,4 [4.66]	200,9 [7.91]
390 [23.9]	127,3 [5.01]	209,6 [8.25]
490 [30.0]	138,2 [5.44]	220,7 [8.69]
625 [38.0]	152,9 [6.02]	235,5 [9.27]
985 [60.0]	192,8 [7.59]	275,1 [10.83]

6000 Series

Installation Information

Bearingless

- 1 Internal spline in mating part to be as follows: Material to be ASTM A304, 8620H. Carbonize to a hardness of 60-64 HRc with case depth (to 50HRc) of 0,076 - 1,02 [.030 - .040] (dimensions apply after heat treat).
- 2 Mating part to have critical dimensions as shown. Oil holes must be provided and open for proper oil circulation.
- 3 Seal to be furnished with motor for proper oil circulation thru splines.

- 4 Some means of maintaining clearance between shaft and mounting flange must be provided.
- 5 Similar to SAE "C" Four Bolt Flange..
- 6 Counterbore designed to adapt to a standard sleeve bearing 50,010 - 50,038 [1.9689 - 1.9700] ID by 60,051 - 60,079 [2.3642 - 2.3653] O.D. (Oilite bronze sleeve bearing).

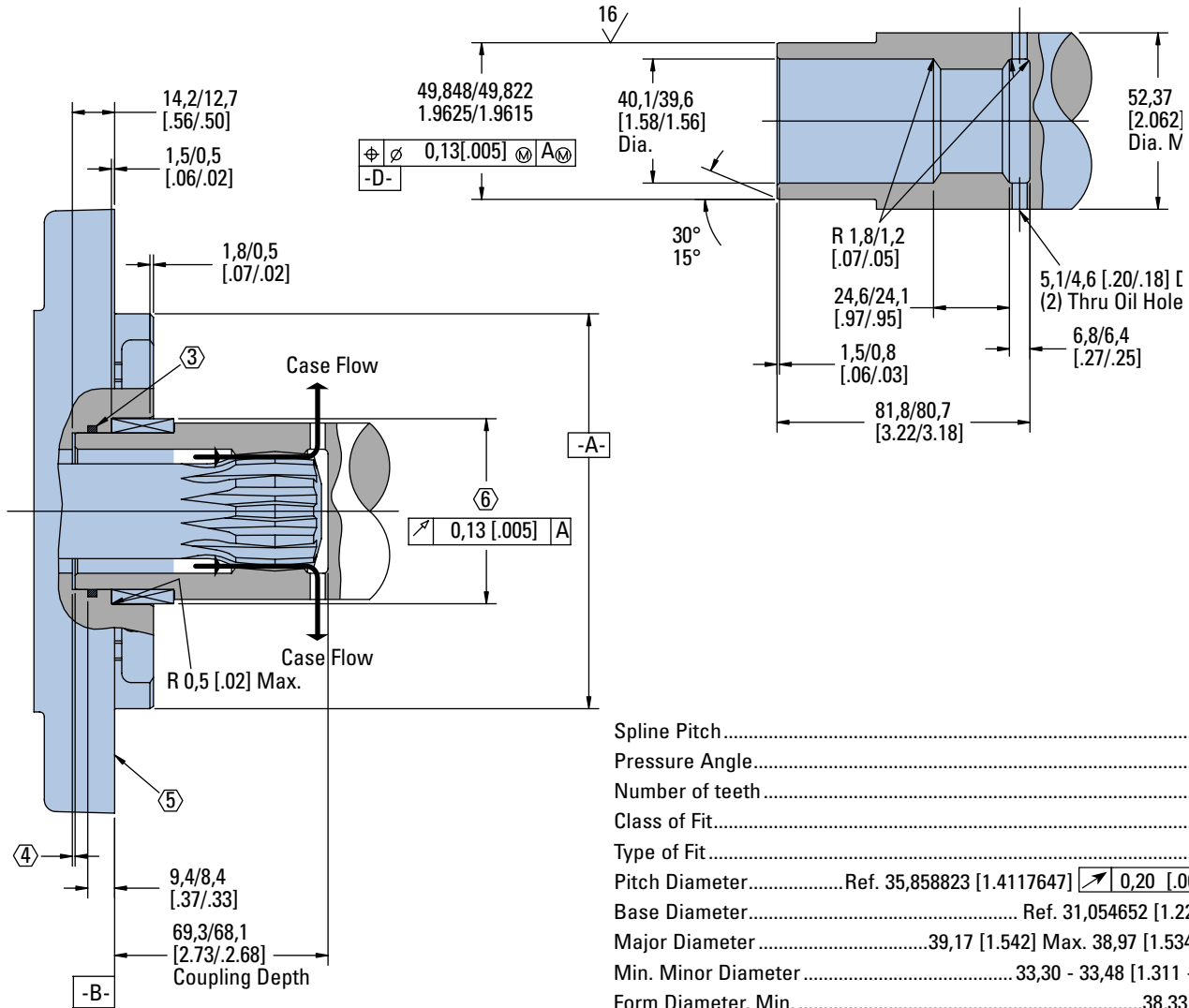

Spline Pitch.....	8.5/17
Pressure Angle.....	30°
Number of teeth.....	12
Class of Fit.....	Ref. 5
Type of Fit.....	Side
Pitch Diameter.....	Ref. 35,858823 [1.4117647] $\begin{matrix} \nearrow \\ 0,20 \\ \searrow \end{matrix}$ [0.008] D
Base Diameter.....	Ref. 31,054652 [1.2226241]
Major Diameter.....	39,17 [1.542] Max. 38,97 [1.534] Min..
Min. Minor Diameter.....	33,30 - 33,48 [1.311 - 1.318]
Form Diameter, Min.	38,33 [1.509]
Fillet Radius.....	0,64 - 0,76 [0.025 - 0.030]
Tip Radius.....	0,25 - 0,51 [0.010 - 0.020]
Finish.....	1,6 (63)
Involute Profile Variation.....	+0,000 -0,025 [+0.0000 -0.0010]
Total Index Variation.....	0,038 [0.0015]
Lead Variation.....	0,013 [0.0005]
Circular Space Width:	
Maximum Actual.....	5,898 [0.2322]
Minimum Effective.....	5,804 [0.2285]
Maximum Effective.....	Ref. 5,857 [0.2306]
Minimum Actual.....	Ref. 5,834 [0.2297]
Dimension Between Two Pins.....	Ref. 26,929 - 27,084 [1.0602 - 1.0663]
Pin Diameter.....	6,223 [0.2450] Pins to Have 4,0 [0.160]
	Wide Flat for Root Clearance

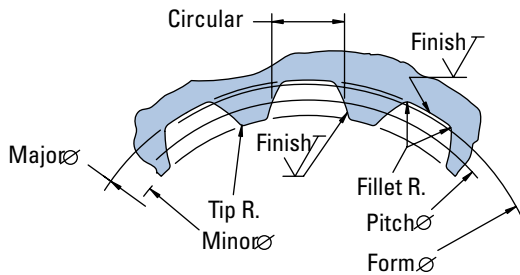

6000 Series

Dimensions

Shafts Splined

1 1/2 Inch Straight

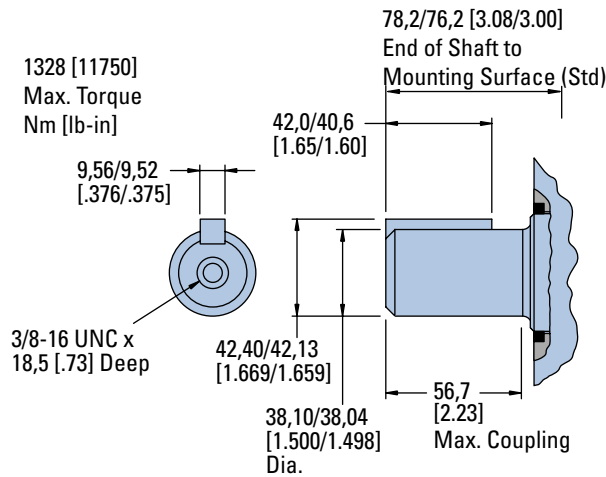

1 3/4 Inch Tapered

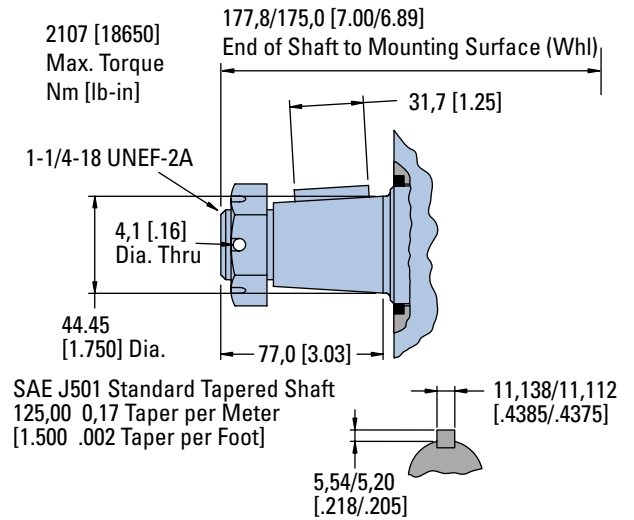

1 1/2 Inch 17 Tooth Splined

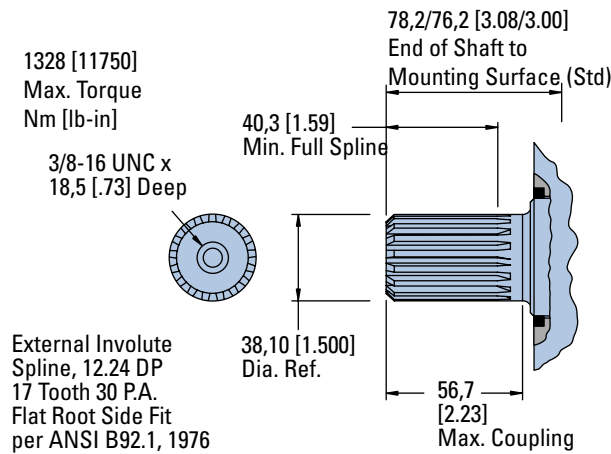

Tapered Shaft Hub Data

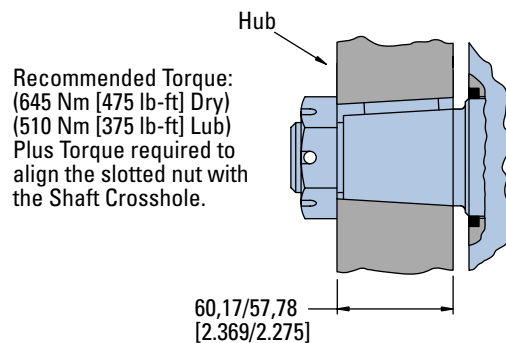

40 mm Straight

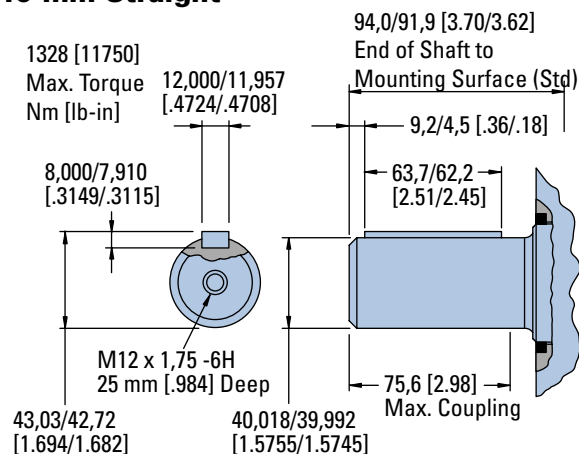

Slotted Hexagon Nut

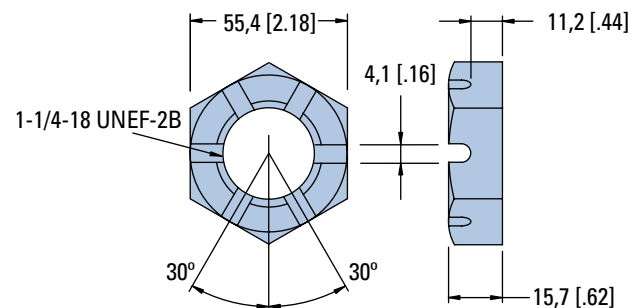

6000 Series

Shaft Side Load Capacity

These curves indicate the radial load capacity on the motor shaft(s) at various locations with an external thrust load of 454 kg [1000 lb]. The maximum allowable thrust load is 908 kg [2000 lb].

Note:

Case pressure will increase the allowable inward thrust load and decrease the allowable outward thrust load. Case pressure will push outward on the shaft at 109 kg/7 Bar [241 lb/100 PSI].

Each curve is based on

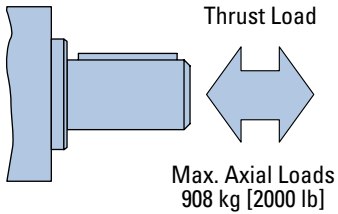

B 10 bearing life (2000 hours of 12,000,000 shaft revolutions at 100 RPM) at rated output torque.

To determine radial load at speeds other than 100 RPM, multiply the load values given on the bearing curve by the factors in the chart below.

RPM	Multiplication Factor
50	1.23
100	1.00
200	0.81
300	0.72
400	0.66
500	0.62
600	0.58
700	0.56
800	0.54

For 3,000,000 shaft revolutions or 500 hours—Increase these shaft loads 52%.

**Standard Motor
Straight and Splined Shafts**

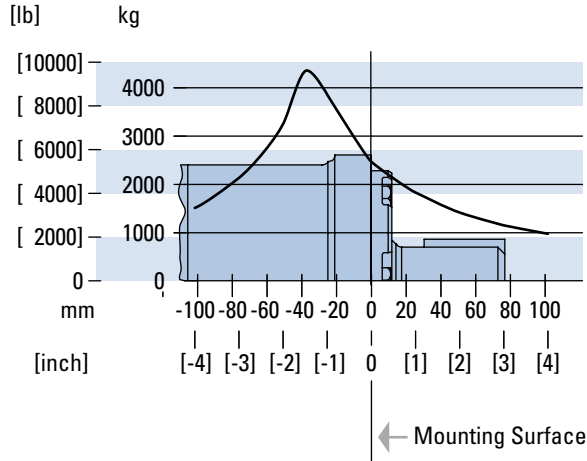

Wheel Motor Tapered Shaft

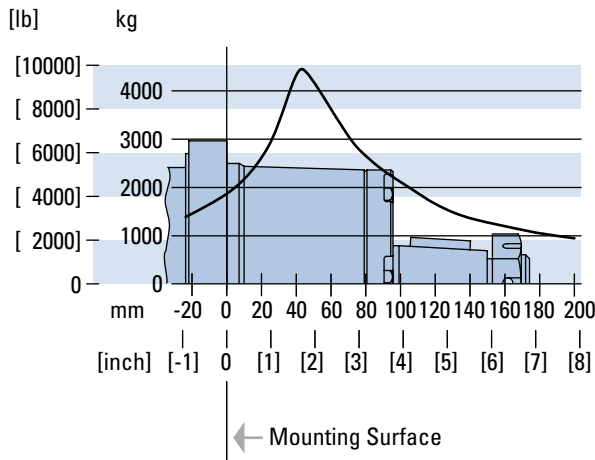

6000 Series

Case Pressure and Case Port

Char-Lynn 6000 Series motors are durable and have long life as long as the recommended case pressure is not exceeded. Allowable case pressure is highest at low shaft speeds. Consequently, motor life will be shortened if case pressure exceeds these ratings (acceptability may vary with application). Determine if an external case drain is required from the case pressure seal limitation chart.

Case Pressure Seal Limitation

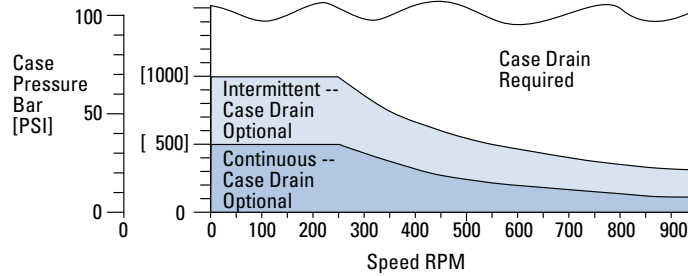

Case Porting Advantage

Contamination Control — flushing the motor case.

Cooler Motor — exiting oil draws motor heat away.

Extend Motor Seal Life — maintain low case pressure with a preset restriction in the case drain line.

6000 Series

Dimensions Ports

1 5/16 -12 O-ring Ports (2) or G 1 (BSP) Ports (2)

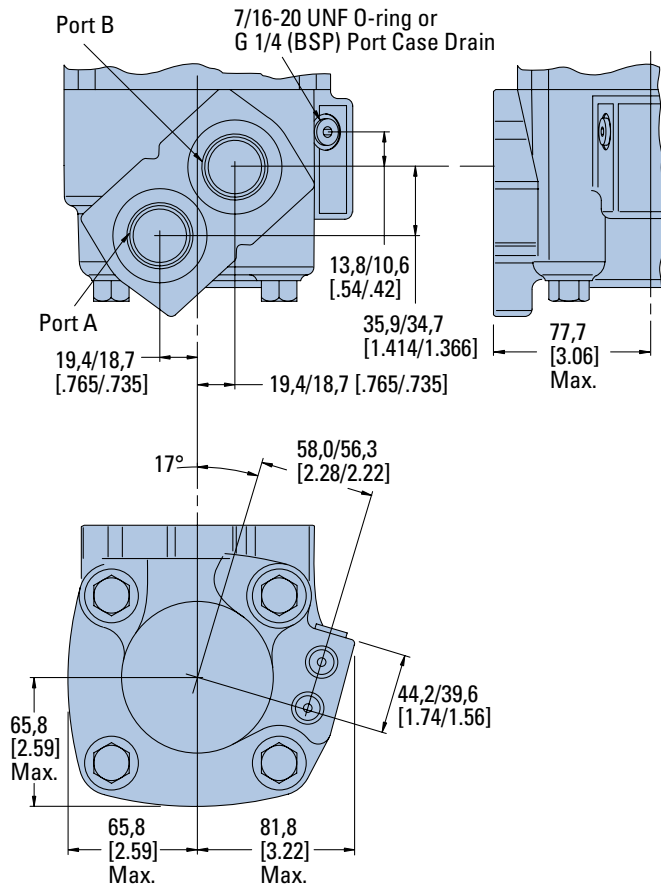

4 Bolt 3/4 Inch Split Flange

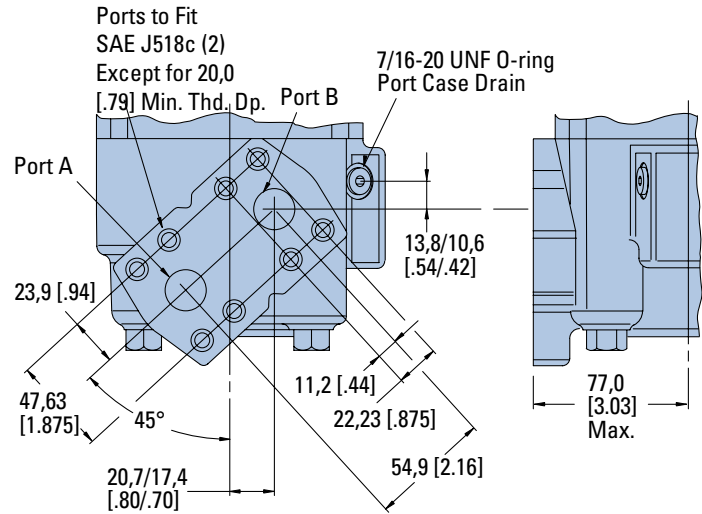

1 5/16 -12 O-ring Ports (2) with Shuttle

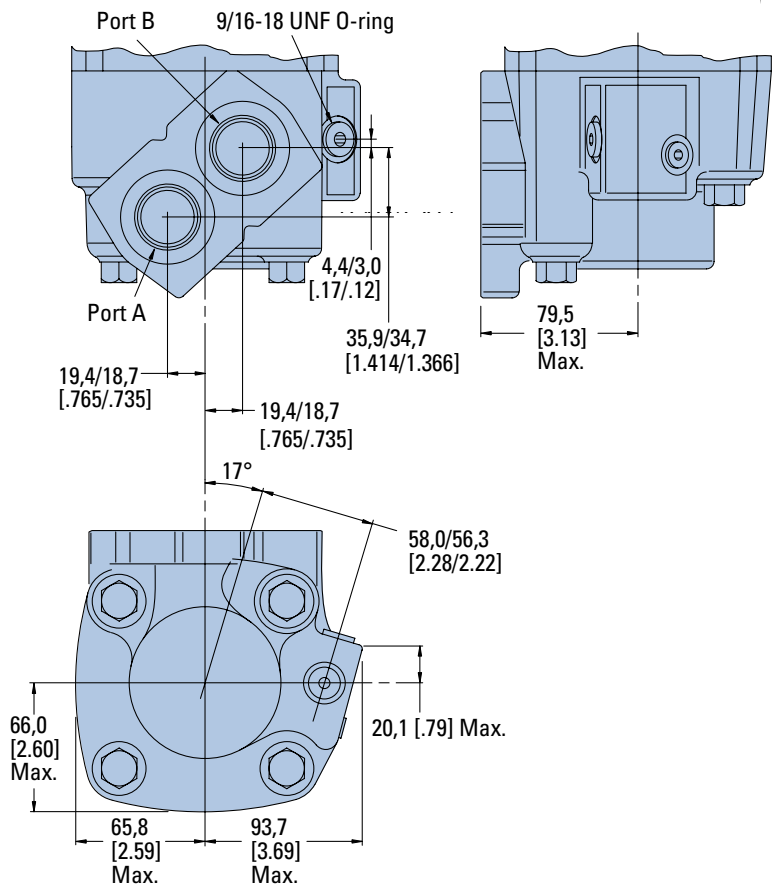

6000 Series

Product Numbers

Note:

For 6000 Series Motors with a configuration **Not Shown** in the charts above: Use model code number system on the next page to specify product in detail.

Use digit prefix — 112-, 113-, or 114 - plus four digit number from charts for complete product number— Example 114-1047.

Orders will not be accepted without three digit prefix.

MOUNTING	SHAFT	PORT SIZE	DISPL. cm ³ /r [in ³ /r] / PRODUCT NUMBER								
			195 [11.9]	245 [15.0]	310 [19.0]	390 [23.9]	490 [30.0]	625 [38.0]	735* [45.0]	805* [49.0]	985 [60.0]
Standard	1 1/2 inch Straight	1 5/16 O-ring	112-1064	-1065	-1066	-1067	-1068	-1107	-1145	—	-1069
	40 mm Straight	G 1 (BSP)	112-1094	-1095	-1096	-1097	-1098	—	—	—	-1099
	1 1/4 Inch 14 T Splined	1 5/16 O-ring	112-1058	-1059	-1060	-1061	-1062	-1109	1163	—	-1063
G 1 (BSP)		112-1088	-1089	-1090	-1091	-1092	—	—	—	-1093	
Wheel Motor	40 mm Straight	G 1 (BSP)	113-1082	-1083	-1084	-1085	-1086	-1100	—	—	-1087
	1-3/4 Inch Tapered	1 5/16 O-ring	113-1070	-1071	-1072	-1073	-1074	-1093	—	—	-1075
Bearingless		1 5/16 O-ring	114-1031	-1032	-1033	-1034	-1035	-1055	—	—	-1036
		G 1 (BSP)	114-1043	-1044	-1045	-1046	-1047	—	—	—	-1048

*New release

114-1047

Mounting Type - Standard (Code H), 4 Bolt:

- 160,0 [6.30] Pilot Dia.
- 18,01 [.709] Dia. Mounting Holes
- 200,0 [7.87] Dia. Bolt Circle

Output Shaft - Straight (Code 21)

Ports - G1 (BSP) Staggered G 1/4 Case Drain (Code C)

Paint - Low Gloss Black (Code A)

Use digit prefix — 112- plus four digit number from charts for complete product number— Example 112-1215.

Orders will not be accepted without three digit prefix.

MOUNTING	SHAFT	PORT SIZE	DISPL. cm ³ /r [in ³ /r] / PRODUCT NUMBER						
			310 [19.0]	390 [23.9]	490 [30.0]	625 [38.0]	735 [45.0]	805 [49.0]	985 [60.0]
Standard	50 mm Straight	G 1 (BSP)	112-1217	-1218	-1215	-1216	-1247	-1219	-1220

112-1215

6000 Series

Model Code

The following 14-digit coding system has been developed to identify all of the configuration options for the 6000 Series motor. Use this model code to specify a motor with the desired features. All 14 digits of the code must be present when ordering. You may want to photocopy the matrix below to ensure that each number is entered in the correct box.

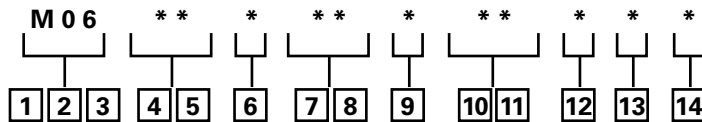

1, 2, 3 Product Series

M06 – 6000 Motor

4, 5 Displacement cm³/r [in³/r]

07 – 110 [6.7]

12 – 195 [11.9]

15 – 245 [15.0]

19 – 310 [19.0]

24 – 390 [23.9]

30 – 490 [30.0]

38 – 625 [38.0]

45 – 740 [45.0]

49 – 805 [49.0]

60 – 985 [60.0]

6 Mounting Type

A – 4 Bolt (Bearingless 127,0 [5.00] Pilot Dia. and 14,3 [.56] Dia. Mounting Holes 161,9 [6.38] Dia. B.C.

B – 4 Bolt (SAE CC) (Standard) 127,0 [5.00] Pilot Dia. and 14,3 [.56] Mounting Holes on 161,9 [6.38] Dia. B.C.

C – 4 Bolt (Wheel) 139,7 [5.50] Pilot Dia. and 14,3 [.56] Dia. Mounting Holes on 184,1 [7.25] Dia. B.C.

H – 4 Bolt (Global) (Standard) 160,0 [6.30] Pilot Dia. and 18,0 [.709] Dia. Mounting Holes on 200,0 [7.87] Dia. Bolt Circle

7, 8 Output Shaft

00 – None (Bearingless)

01 – 1 1/2 inch Dia. Straight with Straight Key, 3/8 -16 Threaded Hole and 56,7 [2.23] Max. Coupling Length

02 – 1 3/4 inch Dia. Tapered with Straight Key and 1-1/4 18 UNEF Slotted Hex. Nut

03 – 1 1/2 inch Dia. Splined 17T with 40,3 [1.59] Min. Full Spline Length and 3/8 -16 Threaded Hole

10 – 40 mm Dia. Straight with Straight Key, M12 x 1,75- 6H Threaded Hole

21 – 50 mm Dia. Straight with Straight Key, 14W x 9H x 70L, M12 x 1,75-6H Thread in End (Available with Mounting Flange Code H Only)

24 – 60 mm Dia. 10:1 Tapered Shaft with M42 x 3-6H Threaded End (Available with Mounting Flange Code H Only)

25 – 2 1/8 inch Dia. Splined 16 Tooth, 55,9 mm [2.20] Min. Full Spline Length (Available with Mounting Flange Code H Only)

9 Ports

A – 1 5/16 - 12 O-ring with 7/16-20 O-ring Case Drain and Check Valve

B – 3/4 inch 4 Bolt Split Flange with 7/16-20 O-ring Case Drain and Check Valve

C – G 1 (BSP) O-ring with G 1/4 (BSP) O-ring Case Drain and Check Valve

D – 1 5/16 -12 O-ring with (2) 9/16-18 O-ring Case Drain Ports and Hot Oil Shuttle Valve

R – 1 5/16 -12 O-ring with (2) 9/16 -18 O-ring Ports for External Lubrication Circuit (both case ports must be connected)

10, 11 Special Features (Hardware)

00 – None

10 – Viton Shaft Seal

07 – Viton Seals

13 – Reverse Rotation

14 – Seal Guard

21 – Speed Sensor (Std.)

12 Paint/ Special Packaging

0 – No Paint, Individual Box

A – Painted Low Gloss Black, Individual Box

B – Corrosion Protected

13 Eaton Assigned Code when Applicable

0 – Assigned Code

14 Eaton Assigned Design Code

0 – Assigned Design Code

10,000 Series

Highlights

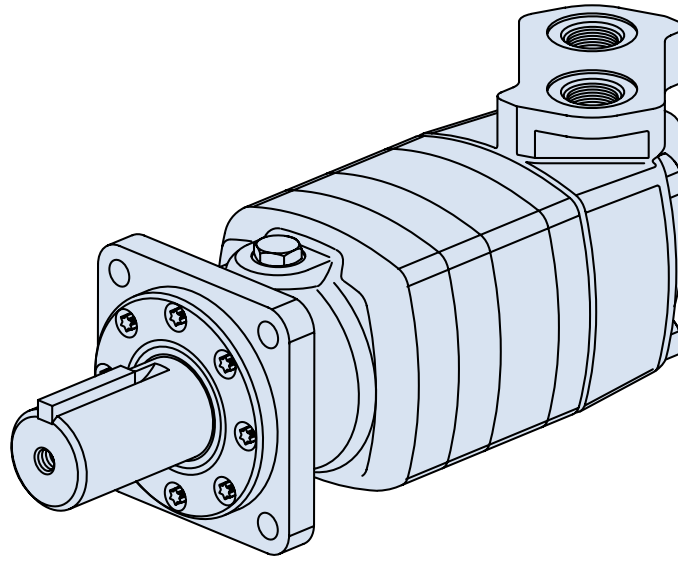

Features

- High torque and flow
- Many options like 2 speed and speed sensors make this motor “smart”
- Low pressure loss even in higher flows

Benefits

- High power density for demanding mobile and industrial applications
- Many options to draw from

Applications

- Boring
- Industrial
- Metal Forming
- Port Equipment
- Saw Mill

Description

This is the biggest disc valve motor of our line up. with up to 45 GPM and 24,000 in-lb of torque in continuous mode, this motor is powerful and yet provides good efficiency.

Specifications

Geroler Element	4 Displacements
Flow l/min [GPM]	170 [45] Continuous**
	265 [70] Intermittent*
Speed RPM	501 Cont.**
	784 Inter.*
Pressure bar [PSI]	200 [3000] Cont.**
	270 [4000] Inter.*
Torque Nm [lb-in]	2700 [23910] Cont.**
	3440 [30460] Inter.*

** Continuous—(Cont.) Continuous rating, motor may be run continuously at these ratings.

* Intermittent—(Inter.) Intermittent operation, 10% of every minute.



Boring



Metal Forming



Port Equipment

10,000 Series

Specifications

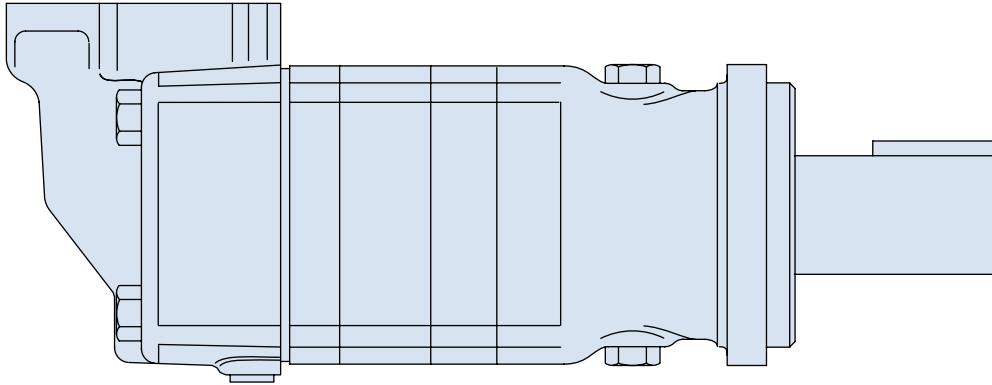

10,000 SERIES MOTORS

Displ. cm ³ /r [in ³ /r]		345 [21.0]	480 [29.3]	665 [40.6]	940 [57.4]
Max. Speed (RPM) @ Flow	Continuous	501	354	254	179
	Intermittent	784	552	396	279
Flow l/min [GPM]	Continuous	170 [45]	170 [45]	170 [45]	170 [45]
	Intermittent	265 [70]	265 [70]	265 [70]	265 [70]
Torque* Nm [lb-in]	Continuous	1040 [9220]	1475 [13050]	2085 [18450]	2700 [23910]
	Intermittent	1390 [12310]	1965 [17410]	2610 [23080]	3440 [30460]
Pressure Δ bar [Δ PSI]	Continuous	205 [3000]	205 [3000]	205 [3000]	190 [2750]
	Intermittent	275 [4000]	275 [4000]	260 [3750]	240 [3500]
	Peak	275 [4000]	275 [4000]	275 [4000]	260 [3750]
Weight kg [lb]	Standard or Wheel Mount	43,5 [96.0]	45,4 [100.0]	46,3 [100.0]	47,2 [104.0]
	Bearingless	31,3 [69.0]	33,1 [73.0]	33,1 [73.0]	34,9 [77.0]

*See shaft torque ratings for limitations..

Note:

To assure best motor life, run motor for approximately one hour at 30% of rated pressure before application to full load. Be sure motor is filled with fluid prior to any load applications.

Maximum Inlet Pressure:

275 bar [4000 PSI]
Do not exceed Δ pressure rating (see chart above).

Maximum Return Pressure:

275 bar [4000 PSI] with case drain line installed.
Do not exceed Δ pressure rating (see chart above).

Δ bar [Δ PSI] :

The true pressure difference between inlet port and outlet port

Continuous Rating:

Motor may be run continuously at these ratings

Intermittent Operation:

10% of every minute

Peak Operation:

1% of every minute

Recommended Fluids:

Premium quality, anti-wear type hydraulic oil with a viscosity of not less than 70 SUS at operating temperature.

Recommended Maximum System Operating Temp.:

82° C [180° F]

Recommended Filtration:





per ISO Cleanliness Code, 4406: 20/18/13

10,000 Series

Performance Data

Motors run with high efficiency in all areas designated with a number for torque and speed. For best motor life select a motor to run with a torque and speed range shown in the light shaded area.

Performance data is typical at 120 SUS. Actual data may vary slightly from unit to unit in production.

	Continuous		Peak
	Intermittent		No Operation

345 cm³/r [21.0 in³/r]
 Δ Pressure Bar [PSI]

	[250] 15	[500] 35	[1000] 70	[1500] 105	[2000] 140	[2500] 170	[3000] 205	[3500] 240	[4000] 275
[1] 3,8	[600] 70 3	[1310] 150 1							
[2] 7,5	[740] 85 21	[1510] 170 19	[3050] 345 15	[4600] 520 11	[6140] 695 8	[7680] 865 4			
[4] 15	[730] 80 43	[1500] 170 41	[3040] 345 37	[4590] 520 33	[6140] 695 30	[7680] 870 26	[9220] 1040 22	[10770] 1215 18	[12310] 1390 14
[8] 30	[720] 80 87	[1490] 170 86	[3030] 340 82	[4580] 515 78	[6120] 690 74	[7670] 865 70	[9210] 1040 66	[10750] 1215 62	[12300] 1390 58
[12] 45	[700] 80 131	[1470] 165 130	[3020] 340 127	[4560] 515 123	[6100] 690 118	[7650] 865 114	[9190] 1040 110	[10740] 1215 106	[12280] 1385 102
[16] 61	[680] 75 176	[1450] 165 175	[3000] 340 172	[4540] 515 167	[6080] 685 163	[7630] 860 158	[9170] 1035 154	[10720] 1210 149	[12260] 1385 145
[20] 76	[660] 75 221	[1430] 160 220	[2970] 335 217	[4520] 510 212	[6060] 685 207	[7600] 860 202	[9150] 1035 198	[10690] 1210 193	[12230] 1380 189
[24] 91	[630] 70 266	[1400] 160 265	[2950] 335 261	[4490] 505 256	[6030] 680 252	[7580] 855 246	[9120] 1030 242	[10660] 1205 237	[12210] 1380 232
[28] 106	[600] 70 310	[1370] 155 309	[2920] 330 306	[4460] 505 301	[6000] 680 296	[7550] 855 291	[9090] 1025 286	[10640] 1200 280	[12180] 1375 275
[32] 121	[570] 65 356	[1340] 150 355	[2890] 325 351	[4430] 500 346	[5970] 675 340	[7520] 850 335	[9060] 1025 329	[10610] 1200 324	[12150] 1370 319
[36] 136	[540] 60 400	[1310] 150 399	[2850] 320 396	[4400] 495 390	[5940] 670 384	[7480] 845 379	[9030] 1020 373	[10570] 1195 368	[12120] 1370 362
[40] 151	[500] 55 445	[1270] 145 444	[2820] 320 441	[4360] 495 435	[5910] 670 429	[7450] 840 423	[8990] 1015 417	[10540] 1190 412	
[45] 170	[460] 50 501	[1220] 140 500	[2760] 310 498	[4300] 485 492	[5840] 660 486	[7380] 835 480	[8910] 1005 473	[10450] 1180 467	
[60] 227		[1080] 130 668	[2620] 295 665	[4160] 470 658	[5710] 645 651	[7250] 820 644	[8800] 995 637		
[70] 265		[960] 110 784	[2510] 285 777	[4050] 460 769	[5590] 630 761	[7140] 805 754	[8680] 980 746		

Flow LPM [GPM]

[2510] } Torque [lb-in]
 285 } Nm
 777 } Speed RPM

480 cm³/r [29.3 in³/r]
 Δ Pressure Bar [PSI]





	[250] 15	[500] 35	[1000] 70	[1500] 105	[2000] 140	[2500] 170	[3000] 205	[3500] 240	[4000] 275
[1] 3,8	[760] 85 6	[1540] 175 5	[3120] 355 4	[4640] 525 2					
[2] 7,5	[1040] 120 15	[2140] 240 13	[4320] 490 11	[6500] 735 8	[8690] 980 5	[10870] 1230 2			
[4] 15	[1040] 120 31	[2130] 240 29	[4310] 485 27	[6490] 735 24	[8680] 980 21	[10860] 1225 18	[13050] 1475 16	[15230] 1720 13	[17410] 1965 10
[8] 30	[1020] 115 62	[2110] 240 61	[4290] 485 58	[6480] 730 55	[8660] 980 53	[10840] 1225 50	[13030] 1470 47	[15210] 1720 44	[17390] 1965 42
[12] 45	[990] 110 94	[2080] 235 93	[4270] 480 90	[6450] 730 87	[8630] 975 84	[10820] 1220 81	[13000] 1470 78	[15180] 1715 75	[17370] 1965 73
[16] 61	[960] 110 125	[2060] 235 124	[4240] 480 122	[6420] 725 119	[8600] 970 116	[10790] 1220 113	[12970] 1465 110	[15150] 1710 107	[17340] 1960 104
[20] 76	[930] 105 157	[2020] 230 156	[4200] 475 154	[6390] 720 150	[8570] 970 147	[10750] 1215 144	[12940] 1460 141	[15120] 1710 138	[17300] 1955 135
[24] 91	[890] 100 189	[1980] 225 188	[4170] 470 185	[6350] 715 182	[8530] 965 179	[10720] 1210 175	[12900] 1460 172	[15080] 1705 169	
[28] 106	[850] 95 221	[1940] 220 220	[4130] 465 217	[6310] 715 214	[8490] 960 210	[10680] 1205 207	[12860] 1455 203	[15040] 1700 200	
[32] 121	[810] 90 252	[1900] 215 251	[4080] 460 249	[6270] 710 245	[8450] 955 242	[10630] 1200 238	[12820] 1450 235	[15000] 1695 231	
[36] 136	[760] 85 282	[1850] 210 281	[4040] 455 280	[6220] 705 277	[8400] 950 273	[10590] 1195 270	[12770] 1445 266		
[40] 151	[710] 80 318	[1800] 205 316	[3990] 450 312	[6170] 695 308	[8350] 945 305	[10540] 1190 301	[12720] 1440 297		
[45] 170	[647] 75 354	[1740] 195 353	[3920] 445 351	[6110] 690 348	[8290] 935 344	[10470] 1185 340	[12660] 1430 336		
[60] 227	[430] 50 474	[1520] 170 473	[3710] 420 471	[5890] 665 467	[8070] 910 462	[10260] 1160 458	[12440] 1405 454		
[70] 265		[1360] 155 552	[3540] 400 550	[5730] 645 546	[7910] 895 541	[10100] 1140 536	[12280] 1385 532		

10,000 Series

Performance Data

Motors run with high efficiency in all areas designated with a number for torque and speed. For best motor life select a motor to run with a torque and speed range shown in the light shaded area.

Performance data is typical at 120 SUS. Actual data may vary slightly from unit to unit in production.

	Continuous		Peak
	Intermittent		No Operation

665 cm³/r [40.6 in³/r]
Δ Pressure Bar [PSI]

	[250] 15	[500] 35	[750] 50	[1000] 70	[1250] 85	[1500] 105	[1750] 120	[2000] 140	[2250] 155	[2500] 170	[2750] 190	[3000] 205	[3250] 225	[3500] 240	[3750] 260
[1] 3.8	[1470] 165 4	[3010] 340 3	[4550] 515 3	[6100] 690 2	[7630] 860 1										
[2] 7.5	[1480] 165 10	[3020] 340 9	[4560] 515 8	[6110] 690 7	[7650] 865 7	[9200] 1040 6	[10740] 1215 5	[12280] 1385 4	[13830] 1565 3	[15370] 1735 2	[16910] 1910 1				
[4] 15	[1470] 165 22	[3010] 340 21	[4550] 515 20	[6100] 690 19	[7640] 865 18	[9190] 1040 17	[10730] 1210 16	[12270] 1385 15	[13820] 1560 14	[15360] 1735 13	[16900] 1910 12	[18450] 2085 11	[19990] 2260 10	[21540] 2435 9	[23080] 2610 8
[8] 30	[1440] 165 44	[2980] 335 43	[4530] 510 42	[6070] 685 41	[7610] 860 40	[9160] 1035 39	[10700] 1210 38	[12250] 1385 37	[13790] 1560 36	[15330] 1730 35	[16880] 1905 34	[18420] 2080 33	[19960] 2255 32	[21510] 2430 31	[23050] 2605 30
[12] 45	[1400] 160 67	[2950] 335 66	[4490] 505 65	[6040] 680 64	[7580] 855 63	[9120] 1030 62	[10670] 1205 61	[12210] 1380 60	[13750] 1555 59	[15300] 1730 58	[16840] 1905 57	[18380] 2075 56	[19930] 2255 55	[21470] 2425 54	[23020] 2600 53
[16] 61	[1360] 155 89	[2910] 330 88	[4450] 505 87	[6000] 675 86	[7540] 850 85	[9080] 1025 84	[10620] 1200 83	[12170] 1375 82	[13710] 1550 81	[15260] 1725 80	[16800] 1900 79	[18340] 2075 78	[19890] 2245 77	[21430] 2420 76	
[20] 76	[1310] 150 112	[2860] 315 111	[4400] 495 110	[5940] 670 109	[7490] 845 108	[9030] 1020 107	[10580] 1195 106	[12120] 1370 105	[13660] 1545 103	[15210] 1715 102	[16750] 1890 101	[18300] 2070 100	[19840] 2240 99		
[24] 91	[1260] 140 135	[2800] 315 134	[4350] 490 132	[5890] 665 131	[7440] 840 130	[8980] 1015 129	[10520] 1190 128	[12070] 1365 127	[13610] 1540 126	[15150] 1710 124	[16700] 1885 123	[18240] 2060 122			
[28] 106	[1200] 135 157	[2750] 310 156	[4290] 485 155	[5840] 660 154	[7380] 835 153	[8920] 1010 151	[10470] 1185 150	[12010] 1355 149	[13550] 1530 148	[15100] 1705 147	[16640] 1880 146				
[32] 121	[1140] 130 180	[2690] 305 179	[4230] 480 177	[5770] 650 176	[7320] 825 175	[8860] 1000 174	[10400] 1175 173	[11950] 1350 172	[13490] 1525 170	[15040] 1700 169	[16580] 1875 168				
[36] 136	[1080] 120 202	[2620] 295 201	[4160] 470 200	[5710] 645 199	[7250] 820 198	[8800] 995 196	[10340] 1170 195	[11880] 1340 194	[13430] 1515 193	[14970] 1690 191	[16510] 1865 190				
[40] 151	[1010] 115 225	[2550] 290 224	[4100] 465 222	[5640] 635 221	[7180] 810 220	[8730] 985 219	[10270] 1160 217	[11810] 1335 216	[13350] 1510 215	[14900] 1685 214	[16440] 1855 212				
[45] 170	[920] 105 254	[2460] 280 252	[4000] 450 251	[5550] 625 249	[7090] 800 248	[8630] 975 247	[10180] 1150 245	[11720] 1325 244	[13260] 1500 243	[14810] 1675 242					
[60] 227	[610] 70 338	[2150] 245 336	[3700] 420 335	[5240] 590 334	[6780] 765 332	[8330] 940 331	[9870] 1115 329	[11420] 1290 328	[12960] 1465 327						
[70] 265	[380] 45 396	[1930] 220 393	[3470] 390 391	[5010] 565 390	[6560] 740 388	[8100] 915 387	[9640] 1090 385	[11190] 1265 384							

940 cm³/r [57.4 in³/r]
Δ Pressure Bar [PSI]

[3470] } Torque [lb-in]
390 } Nm
391 } Speed RPM

	[250] 15	[500] 35	[750] 50	[1000] 70	[1250] 85	[1500] 105	[1750] 120	[2000] 140	[2250] 155	[2500] 170	[2750] 190	[3000] 205	[3250] 225	[3500] 240
[1] 3.8	[2080] 235 3	[4260] 480 2	[6440] 730 1											
[2] 7.5	[2090] 235 7	[4270] 480 6	[6450] 730 5	[8640] 975 4	[10820] 1220 3	[13000] 1470 2	[15190] 1715 1	[17370] 1965 1						
[4] 15	[2080] 235 15	[4260] 480 14	[6440] 730 13	[8620] 975 12	[10810] 1220 11	[12990] 1470 10	[15170] 1715 9	[17360] 1960 8	[19540] 2210 7	[21720] 2455 6	[23910] 2700 5	[26090] 2950 4	[28270] 3195 3	[30460] 3440 2
[8] 30	[2040] 230 31	[4220] 475 30	[6400] 725 29	[8590] 970 28	[10770] 1215 27	[12950] 1465 26	[15140] 1710 25	[17320] 1955 24	[19500] 2200 23	[21690] 2450 22	[23870] 2695 21			
[12] 45	[1990] 225 47	[4170] 470 46	[6350] 715 45	[8540] 965 44	[10720] 1210 43	[12900] 1460 42	[15090] 1705 41	[17270] 1950 40	[19450] 2200 39	[21640] 2445 38				
[16] 61	[1930] 220 63	[4110] 465 62	[6290] 710 60	[8480] 960 60	[10660] 1205 59	[12840] 1450 58	[15030] 1700 57	[17210] 1945 56	[19390] 2190 55					
[20] 76	[1860] 210 79	[4040] 455 78	[6220] 705 77	[8410] 950 76	[10590] 1195 75	[12770] 1445 74	[14960] 1690 73	[17140] 1935 72	[19320] 2185 71					
[24] 91	[1780] 200 95	[3970] 450 94	[6150] 695 93	[8330] 940 92	[10520] 1190 91	[12700] 1435 90	[14880] 1680 89	[17070] 1930 88						
[28] 106	[1700] 190 111	[3890] 440 110	[6070] 685 109	[8250] 930 108	[10440] 1180 107	[12620] 1425 106	[14800] 1675 105	[16990] 1920 104						
[32] 121	[1620] 185 127	[3800] 430 126	[5980] 675 125	[8160] 920 124	[10350] 1170 123	[12530] 1415 122	[14720] 1665 121							
[36] 136	[1520] 170 143	[3710] 420 142	[5890] 665 141	[8070] 910 140	[10260] 1160 139	[12440] 1405 138	[14620] 1650 137							
[40] 151	[1420] 160 159	[3610] 410 158	[5790] 655 157	[7970] 900 156	[10160] 1150 155	[12340] 1395 154	[14520] 1640 153							
[45] 170	[1290] 145 179	[3480] 395 178	[5660] 640 177	[7840] 885 176	[10020] 1130 174	[12210] 1380 173	[14400] 1625 172							
[60] 227	[860] 95 239	[3040] 345 238	[5230] 590 236	[7410] 835 235	[9600] 1085 234	[11780] 1330 233								
[70] 265	[540] 60 279	[2720] 305 278	[4910] 555 276	[7090] 800 275	[9270] 1045 274	[11460] 1295 273								

10,000 Series

Dimensions

Ports

- 1 5/16 -12 UN-2B SAE O-ring Staggered Ports (2)
- 9/16 -18 UNF-2B SAE O-ring Case Drain Port (1) or
- 4 Bolt 1 1/4 inch Split Flange Ports (2)
- 9/16 -18 UNF-2B SAE O-ring Case Drain Port (1)

Standard Rotation Viewed from Shaft End

- Port A Pressurized — CW
- Port B Pressurized — CCW

Standard Mount

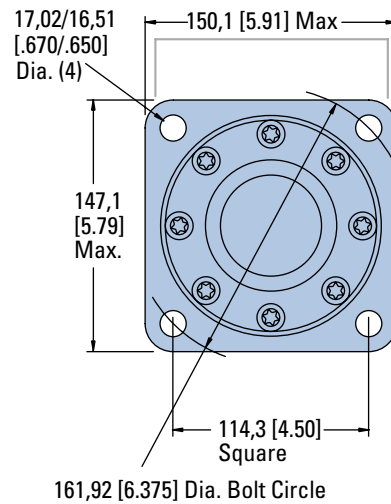
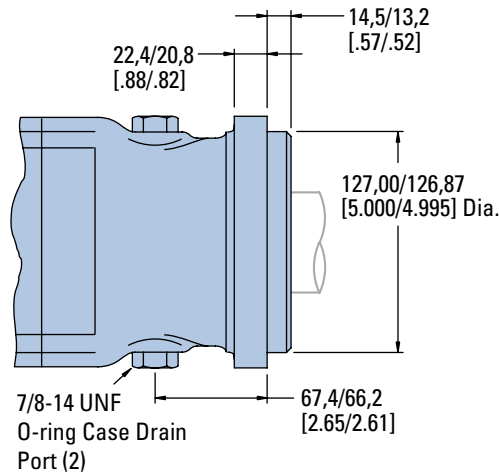
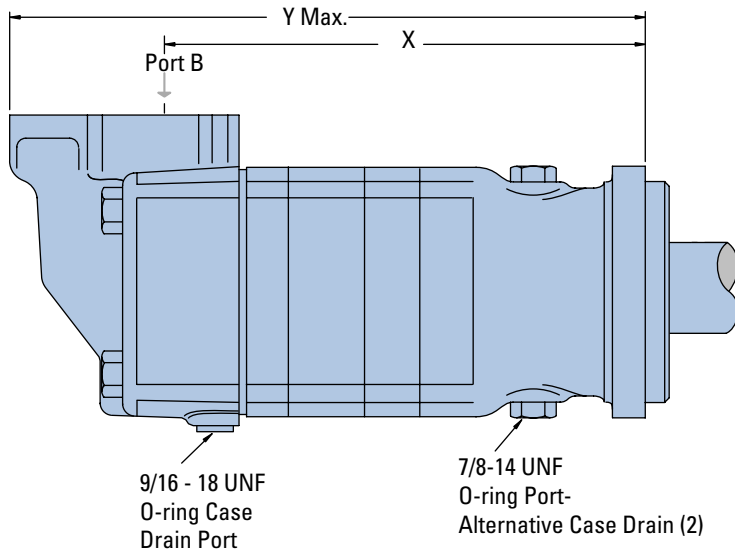

STANDARD MOUNT MOTOR DIMENSIONS

Displacement cm ³ /r [in ³ /r]	X mm [inch]	Y mm [inch]
345 [21.0]	282,4 [11.12]	380,7 [14.99]
480 [29.2]	295,1 [11.62]	393,4 [15.49]
665 [40.6]	295,1 [11.62]	393,4 [15.49]
940 [57.4]	313,4 [12.34]	411,7 [16.21]

10,000 Series

Dimensions

Ports

- 1 5/16 -12 UN-2B SAE O-ring Staggered Ports (2)
- 9/16 -18 UNF-2B SAE O-ring Case Drain Port (1) or
- 4 Bolt 1 1/4 inch Split Flange Ports (2)
- 9/16 -18 UNF-2B SAE O-ring Case Drain Port (1)

Standard Rotation Viewed from Shaft End

- Port A Pressurized — CW
- Port B Pressurized — CCW

Wheel Mount

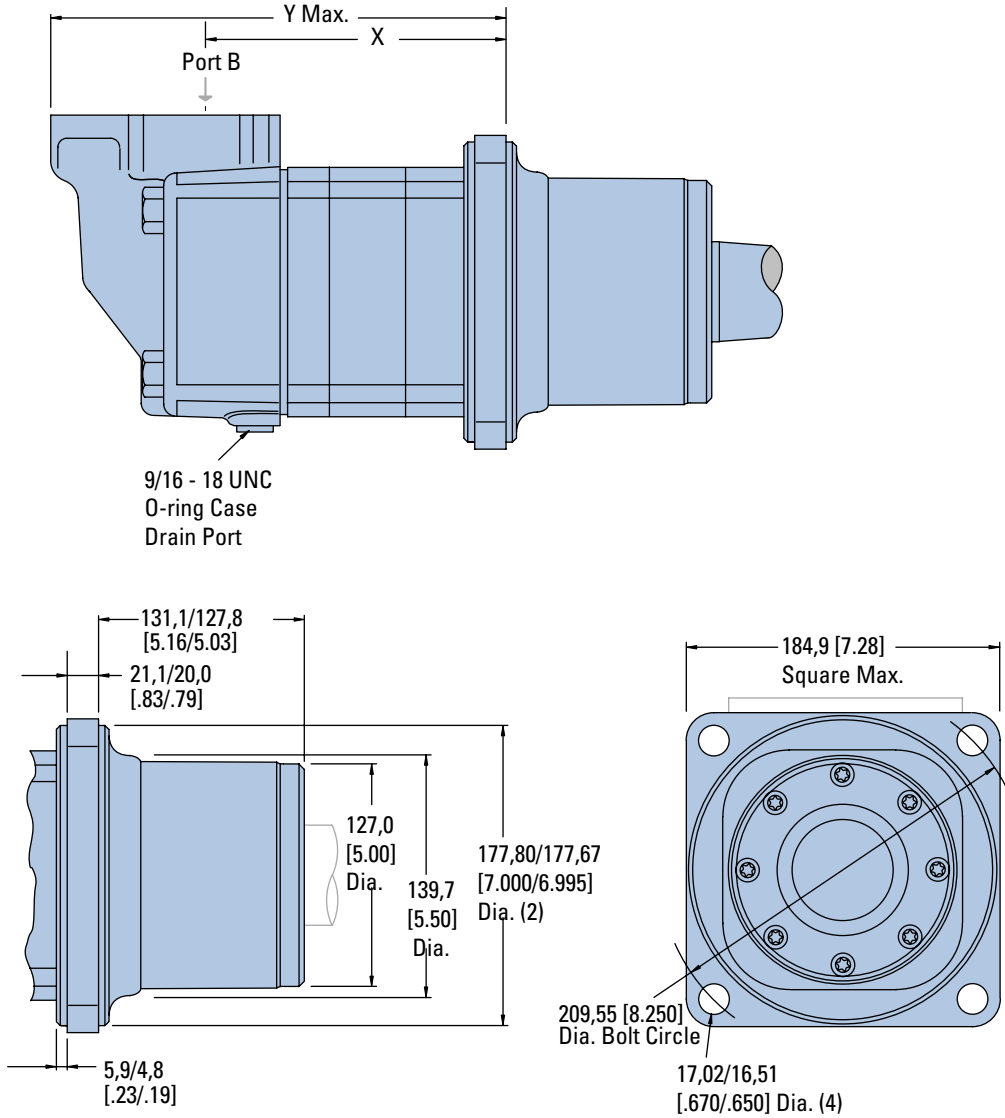

WHEEL MOUNT MOTOR DIMENSIONS

Displacement cm ³ /r [in ³ /r]	X mm [inch]	Y mm [inch]
345 [21.0]	166,9 [6.57]	265,9 [10.47]
480 [29.2]	179,6 [7.07]	278,6 [10.97]
665 [40.6]	179,6 [7.07]	278,6 [10.97]
940 [57.4]	197,8 [7.79]	297,2 [11.70]

10,000 Series

Dimensions

Bearingless

Ports

- 1 5/16 -12 UN-2B SAE O-ring Staggered Ports (2)
- 9/16 -18 UNF-2B SAE O-ring Case Drain Port (1) or
- 4 Bolt 1 1/4 inch Split Flange Ports (2)
- 9/16 -18 UNF-2B SAE O-ring Case Drain Port (1)

Standard Rotation Viewed from Shaft End

- Port A Pressurized — CW
- Port B Pressurized — CCW

Bearingless

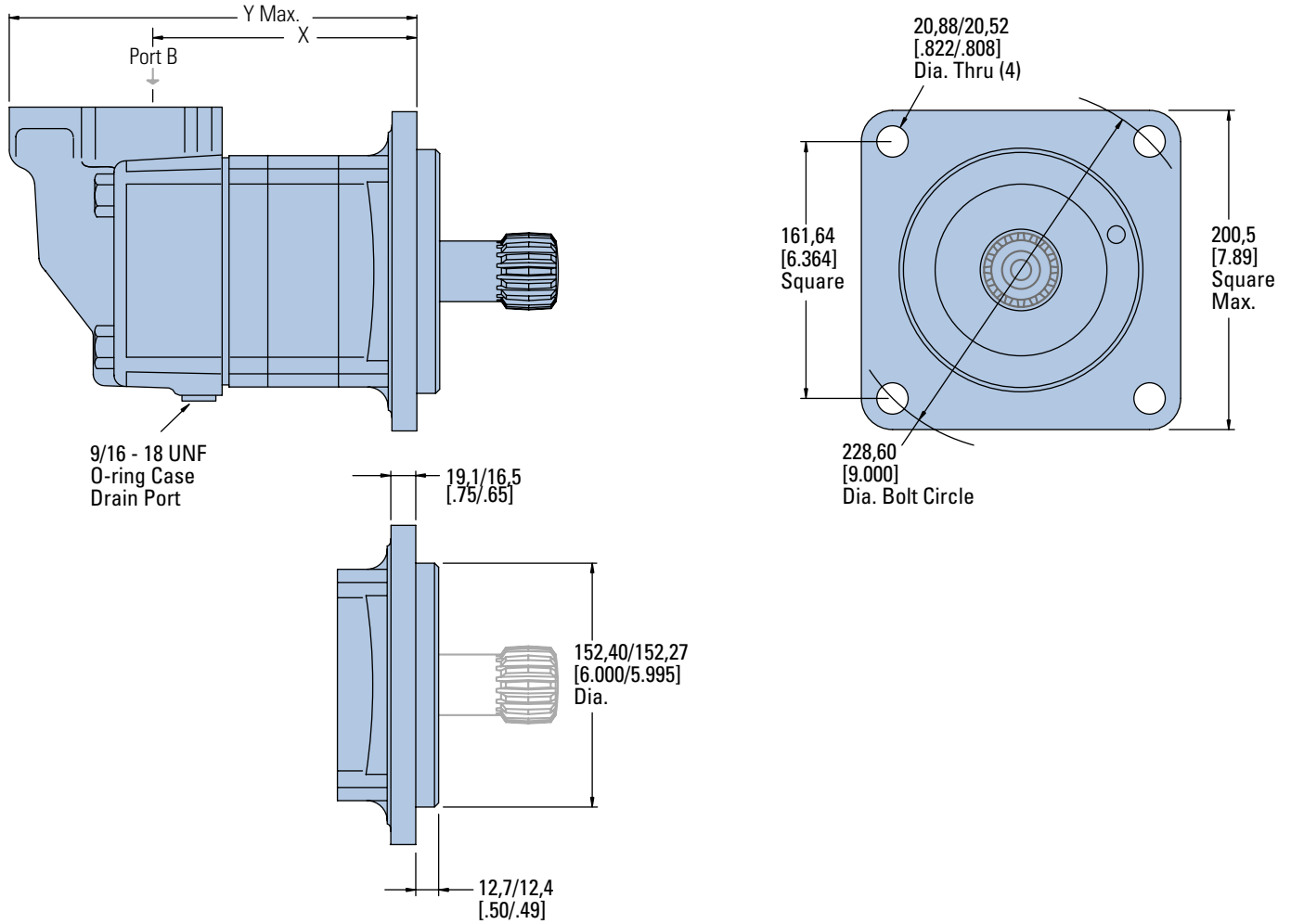

BEARINGLESS MOTOR DIMENSIONS

Displacement cm ³ /r [in ³ /r]	X mm [inch]	Y mm [inch]
345 [21.0]	158,0 [6.22]	256.3 [10.09]
480 [29.2]	170,7 [6.72]	269,0 [10.59]
665 [40.6]	170,7 [6.72]	269,0 [10.59]
940 [57.4]	189,0 [7.44]	287,5 [11.32]

Mating Coupling Blank

Dimension D mm [inch]	Eaton Part No.
133,6/128,5 [5.26/5.06]	13280-001
156,0/150,9 [6.14/5.94]	13280-002

For 10,000 bearingless motor application information, contact your Eaton representative (mating coupling blanks available from Eaton Hydraulics).

Note:

After machining blank, part must be hardened per Eaton specification.

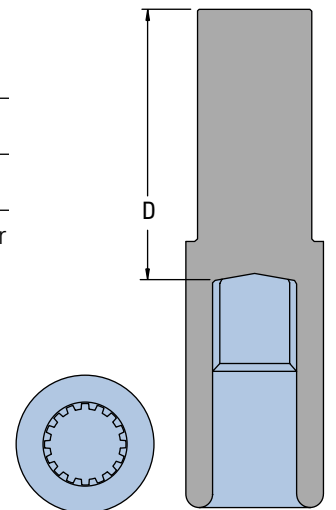

10,000 Series

Installation Information

Bearingless

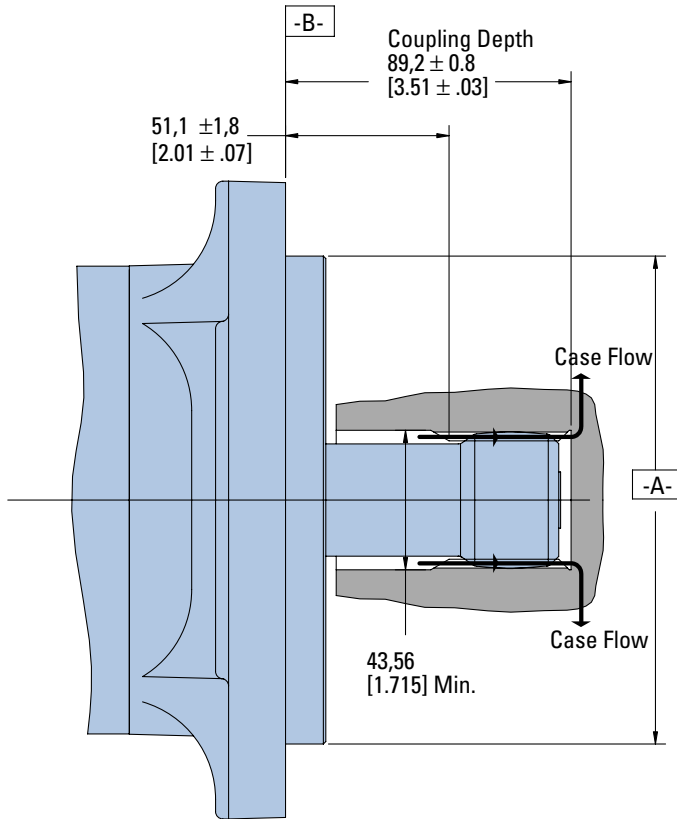

1 Internal spline in mating part to be as follows: Material to be ASTM A304, 8620H. Carbonize to a hardness of 60-64 HRC with case depth (to 50HRC) of 0,076 - 1,02 [.030 - .040] (dimensions apply after heat treat).

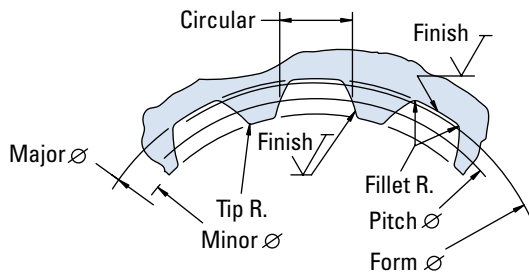

Spline Pitch	10/20
Pressure Angle	30°
Number of teeth	16
Class of Fit	Ref. 5
Type of Fit	Side
Pitch Diameter	Ref. 40,640000 [1.6000000] Ⓢ 0,25 [0.010] D
Base Diameter	Ref. 35,195272 [1.3856406]
Major Diameter	43,56 [1.715] Max. 43,18 [1.700] Min.
Min. Minor Diameter	36,83 - 37,08 [1.450 - 1.460]
Form Diameter, Min.	42,47 [1.672]
Fillet Radius	0,64 - 0,76 [.025 - .030]
Tip Radius	0,25 - 0,51 [.010 - .020]
Finish	1,6 (63)
Involute Profile Variation	+0,000 -0,028 [+0.000 -0.0011]
Total Index Variation	0,041 [.0016]
Lead Variation	0,013 [.0005]
Circular Space Width:	
Maximum Actual	4,105 [.1616]
Minimum Effective	3,995 [.1573]
Maximum Effective	Ref. 4,056 [.1597]
Minimum Actual	Ref. 4,018 [.1582]
Dimension Between Two Pins	Ref. 26,929 - 27,084 [1.0602 - 1.0663]
Pin Diameter	Ref. 34,272 - 34,450 [1.3493 - 1.3563]
	Wide Flat for Root Clearance

10,000 Series

Dimensions

Shafts

2 1/4 Inch Straight

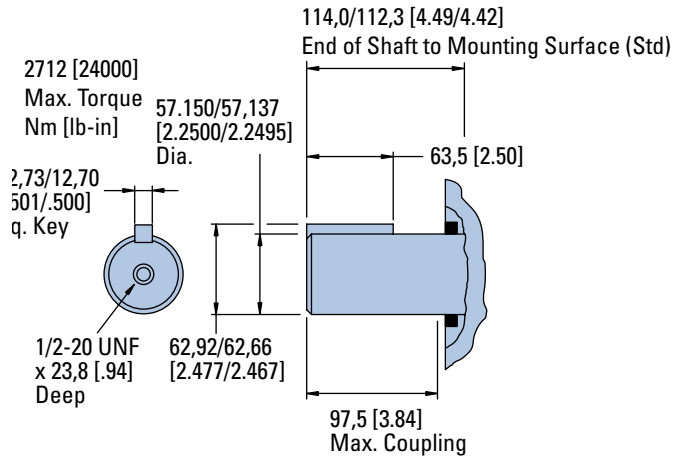

2 1/4 Inch Tapered

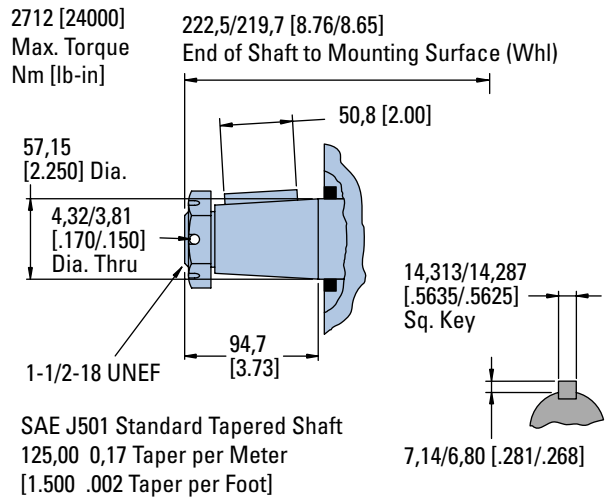

2 1/8 Inch 16 Tooth Splined

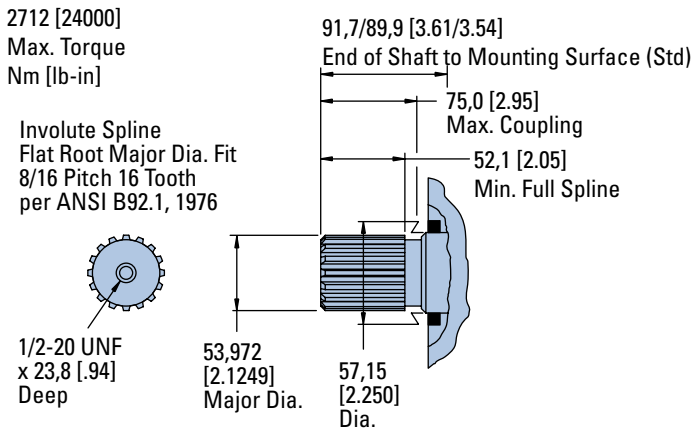

Tapered Shaft Hub Data

Recommended Torque:
(1150 Nm [850 lb-ft] Dry)
(880 Nm [650 lb-ft] Lub)
Plus Torque required to
align the slotted nut with
the Shaft Crosshole.

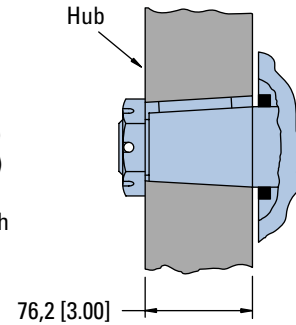

Slotted Hexagon Nut

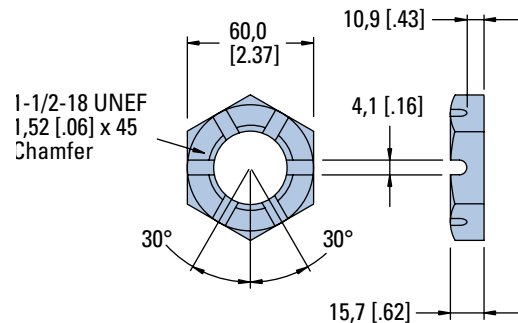

10,000 Series

Side Shaft Load Capacity

These curves indicate the radial load capacity on the motor shaft(s) at various locations with an external thrust load of 454 kg [1000 lb]. The maximum allowable thrust load is 908 kg [2000 lb].

Note:

Case pressure will increase the allowable inward thrust load and decrease the allowable outward thrust load. Case pressure will push outward on the shaft at 200 kg/7 Bar [441 lb/100 PSI].

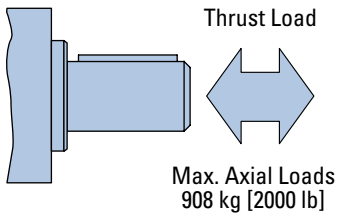

Each curve is based on B 10 bearing life (2000 hours of 12,000,000 shaft revolutions at 100 RPM) at rated output torque.

To determine radial load at speeds other than 100 RPM, multiply the load values given on the bearing curve by the factors in the chart below.

RPM	Multiplication Factor
50	1.23
100	1.00
200	0.81
300	0.72
400	0.66
500	0.62
600	0.58
700	0.56
800	0.54

For 3,000,000 shaft revolutions or 500 hours—Increase these shaft loads 52%.

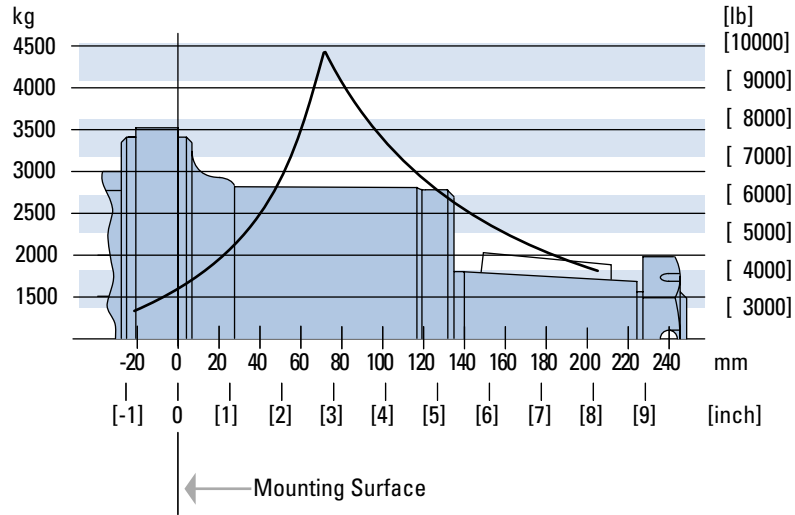
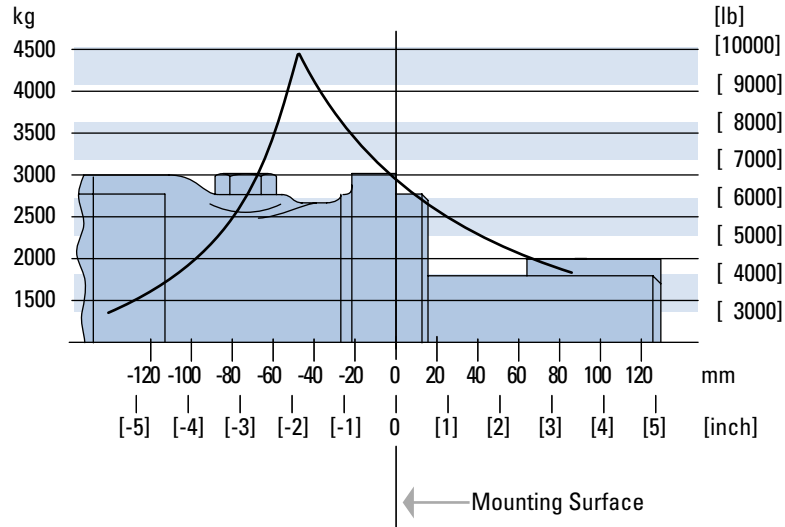

10,000 Series

Dimensions

Ports

1 1/4 Inch Split Flange Ports (2)

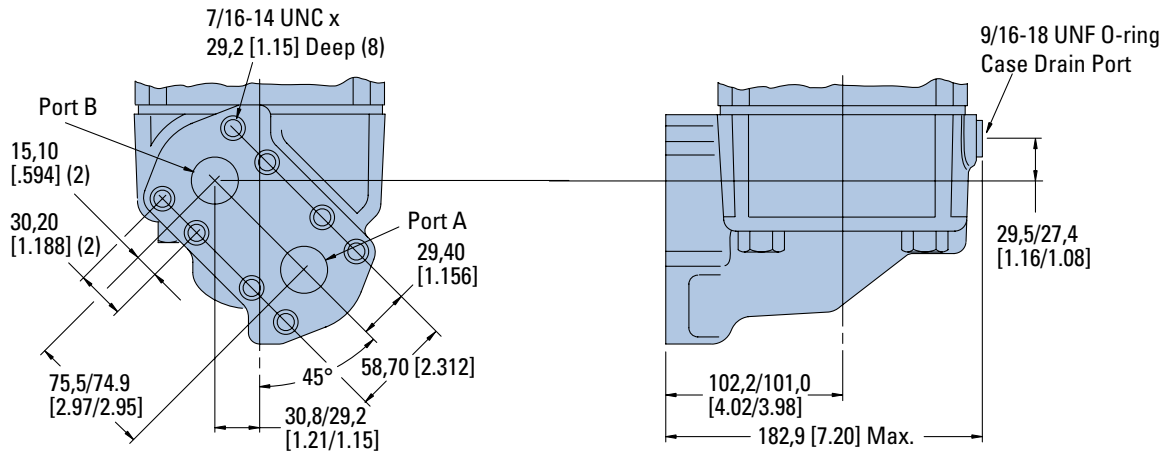

1 5/16 -12 O-ring Ports (2)

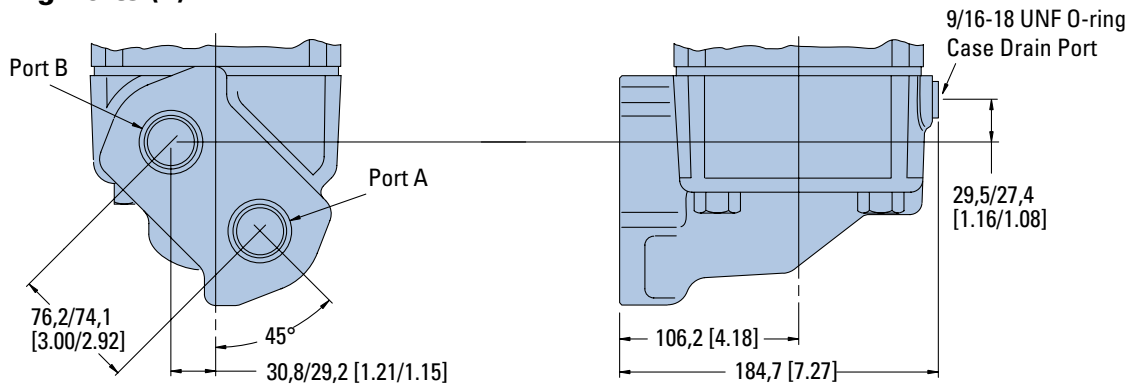

End View Common Dimensions

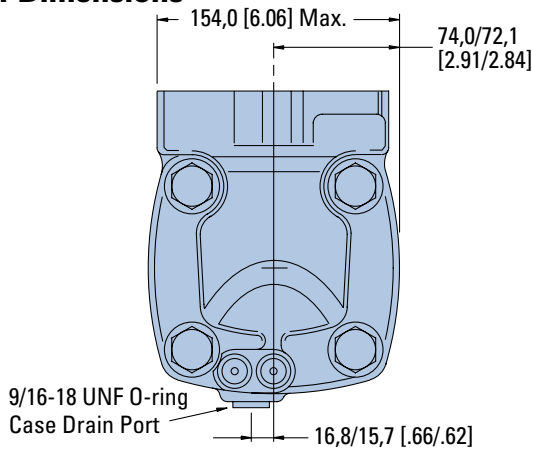

10,000 Series

Product Numbers

Note:

For 10,000 Series Motors with a configuration **Not Shown** in the chart below: Use model code number system on the next page to specify product in detail.

Use digit prefix — 119-, 120-, or 121 - plus four digit number from charts for complete product number— Example 121-1014.

Orders will not be accepted without three digit prefix.

MOUNTING	SHAFT	PORT SIZE	DISPL. cm ³ /r [in ³ /r] / PRODUCT NUMBER			
			345 [21.0]	480 [29.3]	665 [40.6]	940 [57.4]
Standard SAE C-Mount	2 1/4 Inch Straight	1 5/16 O-ring	119-1028	-1029	-1030	-1031
		1 1/4 inch Split Flange	119-1040	-1041	-1042	-1043
	2 1/8 Inch 16 T Splined	1 5/16 O-ring	119-1032	-1033	-1034	-1035
		1 1/4 inch Split Flange	119-1044	-1045	-1046	-1047
	2 1/4 Inch Tapered	1 5/16 O-ring	119-1036	-1037	-1038	-1039
		1 1/4 inch Split Flange	119-1048	-1049	-1050	-1051
Wheel Motor	2 1/4 Inch Straight	1 5/16 O-ring	120-1005	-1006	-1007	-1008
		1 1/4 inch Split Flange	120-1017	-1018	-1019	-1020
	2 1/8 Inch 16 T Splined	1 5/16 O-ring	120-1009	-1010	-1011	-1012
		1 1/4 inch Split Flange	120-1021	-1022	-1023	-1024
	2 1/4 Inch Tapered	1 5/16 O-ring	120-1013	-1014	-1015	-1016
		1 1/4 inch Split Flange	120-1025	-1026	-1027	-1028
Bearingless		1 5/16 O-ring	121-1007	-1008	-1009	-1010
		1 1/4 inch Split Flange	121-1011	-1012	-1013	-1014

121-1014

10,000 Series

Model Code

The following 14-digit coding system has been developed to identify all of the configuration options for the 10,000 Series motor. Use this model code to specify a motor with the desired features. All 14 digits of the code must be present when ordering. You may want to photocopy the matrix below to ensure that each number is entered in the correct box.

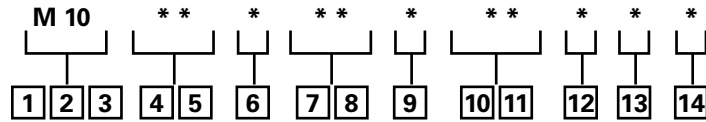

1, 2, 3 Product Series

M10 – 10,000 Motor

4, 5 Displacement cm³/r [in³/r]

20 – 345 [21.0]

29 – 480 [29.2]

40 – 665 [40.6]

57 – 940 [57.4]

6 Mounting Type

A – 4 Bolt (Std.): Dia. 127,0 [5.00] Pilot 16,76 [.660] Mounting Holes on 161,92 [6.375] Dia. Bolt Circle

B – 4 Bolt (Whl.): Dia. 177,8 [7.00] Pilot 16,76 [.660] Mounting Holes on 209,55 [8.250] Dia. Bolt Circle

C – 4 Bolt (Brgl.): Dia. 152,4 [6.00] Pilot 20,70 [.815] Mounting Holes on 228,60 [9.000] Dia. Bolt Circle

7, 8 Output Shaft

00 – None (Bearingless)

01 – 2 1/4 inch Dia. Straight with 12,7 [.50] Square Key x 63,5 [2.50] and 1/2 - 20 Threaded Hole

02 – 2 1/4 inch Dia. Tapered with 14,3 [.56] Square Key x 50,8 [2.00] and 1 1/2 - 18 UNEF -2A Threaded Shaft End and Slotted Hex Nut

03 – 2 1/8 inch 16 Tooth Splined with 52,1 [2.05] Min. Full Spline Length 1/2 - 20 UNF Threaded Hole

9 Ports

A – 1 5/16 -12 UN O-ring End Ports (Size -16), 9/16 - 18 UNF O-ring Case Drain Port (Size - 6)

B – 1 1/4 Inch Split Flange Ports, 9/16 - 18 UNF O-ring Case Drain Port (Size - 6)

10, 11 Special Features (Hardware)

00 – None

01 – Free Running Geroler

03 – Reverse Rotation

12 Paint/ Special Packaging

0 – No Paint, Individual Box

A – Painted Low Gloss Black, Individual Box

13 Eaton Assigned Code when Applicable

0 – Assigned Code

14 Eaton Assigned Design Code

0 – Assigned Design Code

10,000 Series Two-Speed

Description

The Eaton 10,000 Series motors are available with an integral two speed feature that changes the displacement in a ratio of 1 to 2 and shifts the motor from a low speed high torque (LSHT) mode to a high speed low torque (HSLT) mode. The open center selector valve shifts the speed mode from low to high speed when pilot pressure of 6.9 Δ Bar [100 Δ PSI] minimum is applied to the pilot port (6.9 Bar [100 PSI] higher than case pressure). In the high speed mode torque values are approximately one half with twice the speed of the conventional 10,000 Series single speed motors.

An external two position three way valve is required for shifting the pilot pressure port between signal pressure (HSLT) and low pressure (LSHT)

Two speed motors are available with a return line closed center shuttle for closed circuit applications.

Low speed high torque mode is the normal position of the speed selector valve. When a differential pressure is supplied to the pilot port and 6,9 Bar [100 PSI] is reached, the selector valve overcomes the return spring force and the spool shifts to the high speed mode. The oil in the opposite side of the spool is drained internally. Pressure between the pilot supply and case drain or return line (depending on open or closed circuit system) must be maintained to keep the motor in the high speed mode.

When pilot pressure is removed from the pilot port the pressure in the pilot end of the spool valve is relieved and drained back through this three way valve, the spring force returns the spool valve to LSHT position.

Pilot pressure may come from any source that will provide uninterrupted pressure during the high speed mode operation. Pilot pressure 6,9 Δ Bar [100 Δ PSI] minimum, up to the full operating pressure of the motor.

In normal LSHT operation the Char-Lynn two speed motor will function with equal shaft output in either direction (CW or CCW), the same as the single speed Char-Lynn disc valve motors.

However, to prevent cavitation in the HSLT mode, the preferred direction of shaft rotation is counter clockwise (port B pressurized). This unique disc valve is not symmetrical in porting the fluid for the HSLT mode. Consequently, when the pressure is reversed for HSLT CW rotation, cavitation can occur. Installing a restriction (200 PSI or more depending on flow) in the hydraulic line that connects port B will prevent cavitation.

If you are operating in a critical area and a restriction in the hydraulic line causes concern, these two speed motors can be ordered timed with CW preferred HSLT shaft rotation. Hence, with this option port B will have to be pressurized for CW preferred HSLT shaft rotation. The restriction recommended for the line connecting port B remains unchanged. Finally in closed circuit applications a hydraulic line restriction is not required. Instead, the charge pump can be used to supply and maintain a minimum pressure of 14 Bar [200 PSI].

Note:

Be certain in closed loop applications that the charge pump when used for back pressure on the B port, has sufficient displacement to maintain charge pressure especially in dynamic braking or overrunning load conditions.

Important!

Due to potential problems in maintaining charge pump pressure at port B for uninterrupted back pressure during dynamic braking, Eaton does not recommend the two speed motor where overrunning conditions may exist.

Performance Data

10,000 Series Two-Speed

In the high speed mode torque values are approximately one half with twice the speed of the conventional 10,000 Series single speed motors.

In the low speed mode torque and speed values are the same as the conventional 10,000 series single speed motors.

10,000 Series Two-Speed

Typical Hydraulic Circuit

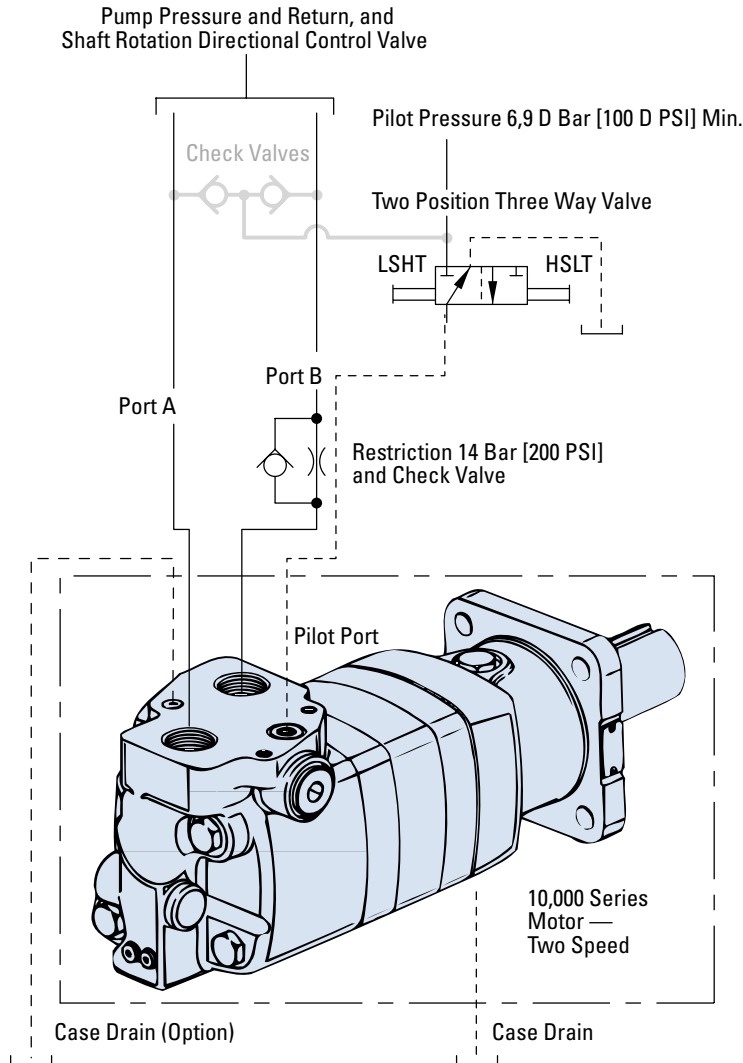

Note:

The schematic diagram below applies to 10,000 series two-speed motors – differs only in orientation of shift valve spool and spring (this orientation of spool and spring positions the pilot port on the opposite side of the port face).

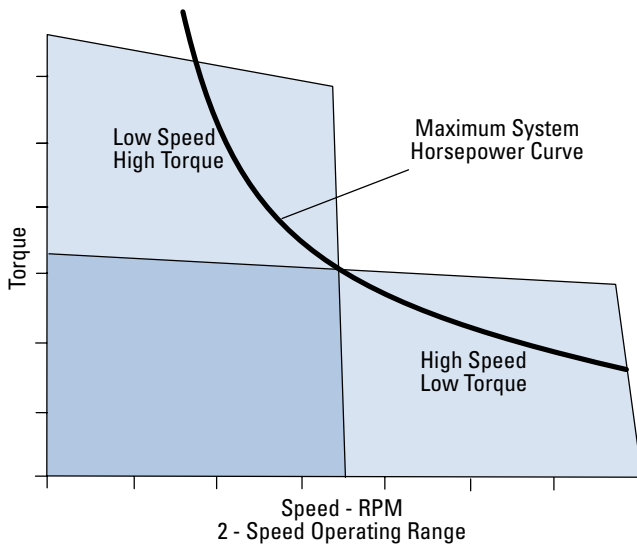
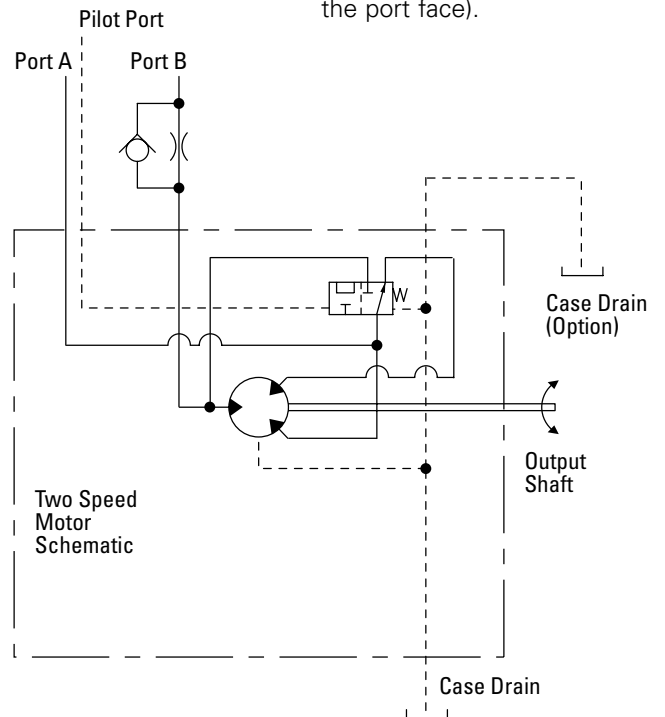

10,000 Series Two-Speed

Specifications

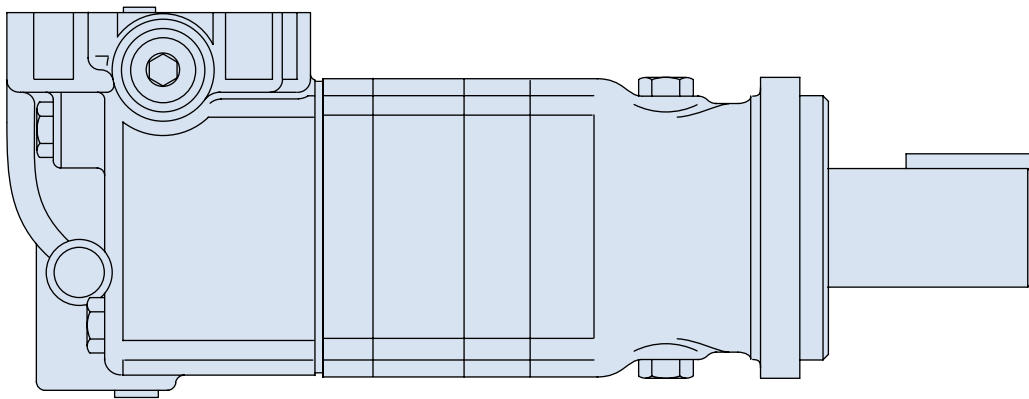

10,000 SERIES TWO-SPEED MOTORS

Displ. cm ³ /r [in ³ /r]	High Speed Mode	169 [10.3]	239 [14.6]	332,7 [20.3]	470 [28.7]
	Low Speed Mode	345 [21.0]	480 [29.3]	665 [40.6]	940 [57.4]
Max. Speed (RPM) @ Continuous Flow	High Speed Mode	750	630	500	400
	Low Speed Mode	375	315	250	200
Flow l/min [GPM]	High Speed Mode	130 [35]	170 [45]	170 [45]	170 [45]
	Low Speed Mode	130 [35]	170 [45]	170 [45]	170 [45]
Torque* Nm [lb-in]	High Speed Mode				
	Continuous	440 [3900]	630 [5600]	905 [8000]	1175 [10400]
	Intermittent	585 [5200]	845 [7500]	1130 [10000]	1470 [13000]
Torque* Nm [lb-in]	Low Speed Mode				
	Continuous	1015 [9000]	1470 [13000]	2090 [18500]	2710 [24000]
	Intermittent	1355 [12000]	1965 [17400]	2600 [23000]	3445 [30500]
Pressure Δ bar [Δ PSI]	Continuous	205 [3000]	205 [3000]	205 [3000]	190 [2750]
	Intermittent	275 [4000]	275 [4000]	260 [3750]	240 [3500]
Weight kg [lb]	Standard or Wheel Mount	50,3 [111.0]	52,2 [115.0]	52,2 [115.0]	54,0 [119.0]
	Bearingless	38,1 [84.0]	39,9 [88.0]	39,9 [88.0]	41,7 [92.0]

*See shaft torque ratings for limitations..

Note:

To assure best motor life, run motor for approximately one hour at 30% of rated pressure before application to full load. Be sure motor is filled with fluid prior to any load applications.

High Speed Mode

(Reduced Motor Displacement)

Low Speed Mode

(Full Motor Displacement)

Maximum Inlet Pressure:

275 bar [4000 PSI]

Do not exceed Δ pressure rating (see chart above).

Maximum Return Pressure:

275 bar [4000 PSI] with case drain line installed.

Do not exceed Δ pressure rating (see chart above).

Δ bar [Δ PSI] :

The true pressure difference between inlet port and outlet port

Continuous Rating:

Motor may be run continuously at these ratings

Intermittent Operation:

10% of every minute

Peak Operation:

1% of every minute

Recommended Fluids:

Premium quality, anti-wear type hydraulic oil with a viscosity of not less than 70 SUS at operating temperature.

Recommended Maximum System Operating Temp.:

82° C [180° F]

Recommended Filtration:

per ISO Cleanliness Code, 4406: 20/18/13

10,000 Series Two-Speed

Dimensions

Standard and Wheel

Ports

- 1 5/16 -12 UN-2B SAE O-ring Staggered Ports (2)
- 3/4 -16 UNF-2B SAE O-ring Case Drain Port (1)
- 7/16 -20 UNF-2B SAE O-ring Pilot Control Port (1) or
- 4 bolt 1 1/4 inch Split Flange Ports (2)
- 3/4 -16 UNF-2B SAE O-ring Case Drain Port (1)
- 7/16 -20 UNF-2B SAE O-ring Pilot Control Port (1)

Standard Rotation Viewed from Shaft End

- Port A Pressurized — CW
- Port B Pressurized — CCW

1 5/16 -12 O-ring Staggered Ports

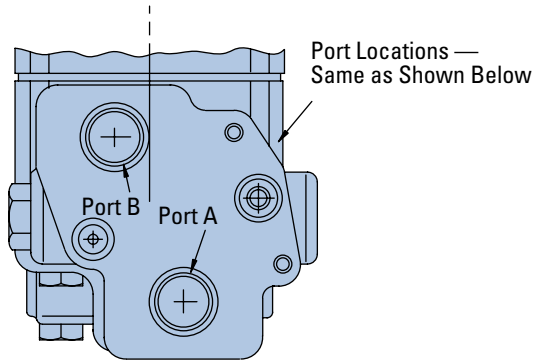

Two-Speed Standard Motors

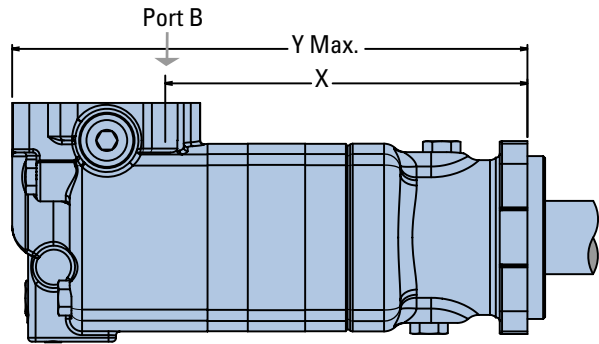

STANDARD MOUNT MOTOR DIMENSIONS

Displacement cm ³ /r [in ³ /r]	X mm [inch]	Y mm [inch]
345 [21.0]	270,8 [10.66]	392,7 [15.46]
480 [29.2]	283,5 [11.16]	405,4 [15.96]
665 [40.6]	283,5 [11.16]	405,4 [15.96]
940 [57.4]	301,8 [11.88]	423,7 [16.68]

4 Bolt 1 1/4 Inch Split Flange Ports

7/16-20 UNF-2B O-ring Port — Pilot Control
Pilot Port Pressurized 6,9 Δ Bar [100 Δ PSI]
High Speed Low Torque (HSLT)

Pilot Port Depressurized (Tank)
Low Speed High Torque (LSHT)

1/2-20 UNF-2B
O-ring Case Drain Option
Port Size 5

Groove Provided for Seal
25,38 [.999] OD x 2,41 [.095]
Wide 1,19 [.047] Deep

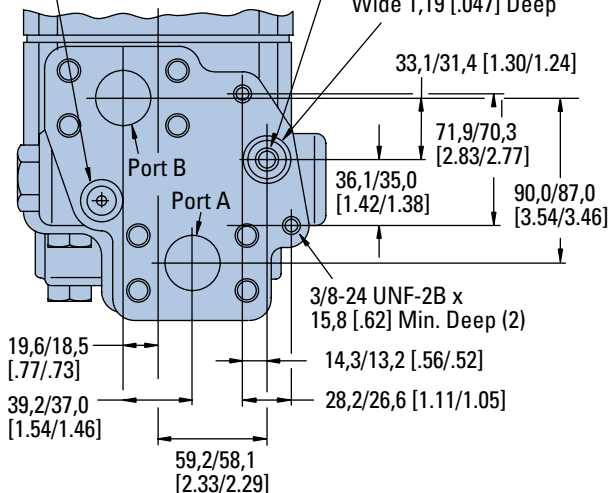

Two-Speed Wheel Motors

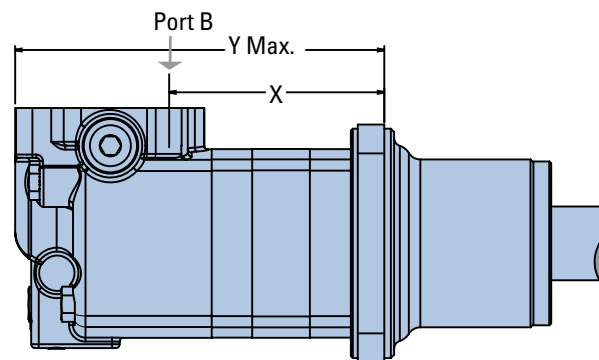

WHEEL MOUNT MOTOR DIMENSIONS

Displacement cm ³ /r [in ³ /r]	X mm [inch]	Y mm [inch]
345 [21.0]	155,2 [6.11]	277,9 [10.94]
480 [29.2]	167,9 [6.61]	290,6 [11.44]
665 [40.6]	167,9 [6.61]	290,6 [11.44]
940 [57.4]	186,2 [7.33]	309,1 [12.17]

10,000 Series Two-Speed

Dimensions

Bearingless

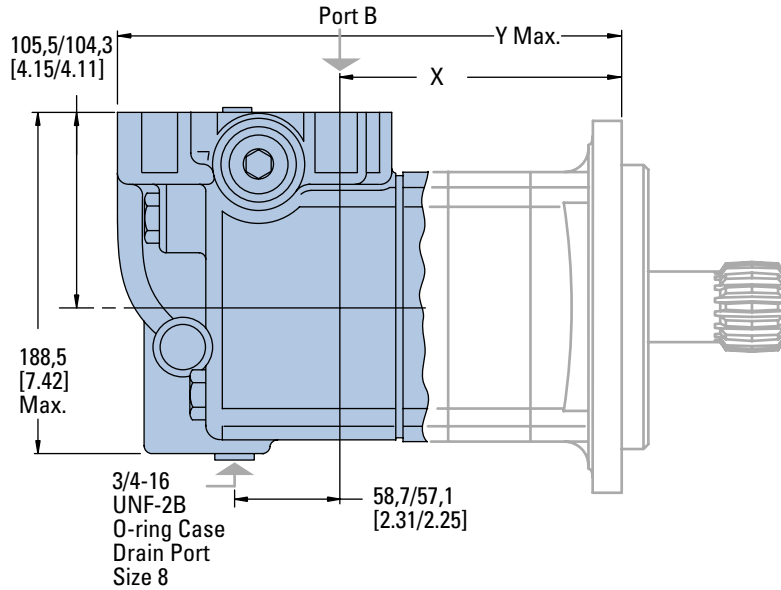
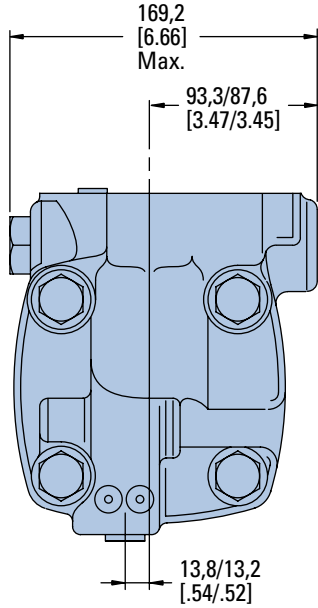

Ports

- 1 5/16 -12 UN-2B SAE O-ring Staggered Ports (2)
- 3/4 -16 UNF-2B SAE O-ring Case Drain Port (1)
- 7/16 -20 UNF-2B SAE O-ring Pilot Control Port (1) or
- 4 bolt 1 1/4 inch Split Flange Ports (2)
- 3/4 -16 UNF-2B SAE O-ring Case Drain Port (1)
- 7/16 -20 UNF-2B SAE O-ring Pilot Control Port (1)

Standard Rotation Viewed from Shaft End

- Port A Pressurized — CW
- Port B Pressurized — CCW

BEARINGLESS MOTOR DIMENSIONS

Displacement cm ³ /r [in ³ /r]	X mm [inch]	Y mm [inch]
345 [21.0]	146,3 [5.76]	268,2 [10.56]
480 [29.2]	159,0 [6.26]	280,9 [11.06]
665 [40.6]	159,0 [6.26]	280,9 [11.06]
940 [57.4]	177,3 [6.98]	299,5 [11.79]

10,000 Series Two-Speed

Product Numbers

Note:

For 10,000 Series Motors with a configuration **Not Shown** in the chart below: Use model code number system on the page C-5-13 to specify product in detail.

Use digit prefix — 119-, 120-, or 121 - plus four digit number from charts for complete product number— Example 121-2002.

Orders will not be accepted without three digit prefix.

MOUNTING	SHAFT	PORT SIZE	DISPL. cm ³ /r [in ³ /r] / PRODUCT NUMBER			
			345 [21.0]	480 [29.3]	665 [40.6]	940 [57.4]
Standard	2 1/4 Inch Straight	1 5/16 O-ring	119-2013	-2014	-2015	-2016
		1 1/4 inch Split Flange	119-2001	-2002	-2003	-2004
	2 1/8 Inch 16 T Splined	1 5/16 O-ring	119-2021	-2022	-2023	-2024
		1 1/4 inch Split Flange	119-2009	-2010	-2011	-2012
	2 1/4 Inch Tapered	1 5/16 O-ring	119-2017	-2018	-2019	-2020
		1 1/4 inch Split Flange	119-2005	-2006	-2007	-2008
Wheel Motor	2 1/4 Inch Straight	1 1/4 inch Split Flange	120-2005	-2006	-2007	-2008
		2 1/8 Inch 16 T Splined	1 1/4 inch Split Flange	120-2009	-2010	-2011
	2 1/4 Inch Tapered	1 5/16 O-ring	120-2013	-2014	-2015	-2016
		1 1/4 inch Split Flange	120-2001	-2002	-2003	-2004
Bearingless	2 1/4 Inch Straight	1 5/16 O-ring	121-2005	-2006	-2007	-2008
		1 1/4 inch Split Flange	121-2001	-2002	-2003	-2004

121-2002