

Table of Contents

Introduction	4
Model Codes	
Form Page	5
Basic Pump	6
ES Control	7
HG Control	8
FE Control	9
DP Control	10
SP Control	11
Special Features	12
Combination Units	13
Examples for Combination Units	14
Pump Specifications	
US	15
Metric	16
Performance Curves	17
Operating Data	18
Hydraulic Transmission Circuit	19
Controls	
FE, HG Manual Adjustment Displacement Control	20
Electric Motor Displacement Control ES	21
Pressure Signal Displacement Control DP	22
Example for TVX, DP Control	23
Proportional Valve Displacement Control SP	24
Example for TVX, SP Control	25
Pump Dimensions*	
TVXS 066/090 ES Control	26
TVXS 066/090 HG Control	28
TVXS 066/090 FE Control	30
TVXS 066/090 DP Control	32
TVXS 066/090 SP Control	34
TVXS 130/180 ES Control**	36

Table of Contents

(cont.)

Pump Dimensions* (cont.)

TVXS 130/180 HG Control**	38
TVXS 130/180 FE Control**	40
TVXS 130/180 DP Control**	42
TVXS 130/180 SP Control**	44
* TVXS-250 ask for special drawings. Used only for replacement. For new applications please use TVWS	
** TVXS –130/180 , for new applications please use TVWS-130/180	
SAE 4-Bolt Mounting Pads	46
Application Data	47
Fluid Recommendations	48
Application Information	49

Introduction

- Axial piston pumps with swashplate design for reliable operation and long life.
- Special design for closed loop application.
- Pressure up to 420 bar. Rated speed up to 1800 r/min higher speeds possible.
- Rotating and pressure loaded parts are pressure balanced.
- Oversize shaft and shaft bearings.
- Large charge flow rates for low system temperature.
- Wide range of available integrated charge and pilot pressure pump combinations.
- Standard available transmission circuits with integrated valves and filters to build complete closed loop system for charge flow and flushing.
- Fast response times.
- For new product applications use TVW. Use TVX 130-250 for service replacement only.

AVAILABLE DISPLACEMENT SIZES

66 ccm

90 ccm

AVAILABLE REPLACEMENT UNIT DISPLACEMENT SIZES

130 ccm

180 ccm

250 ccm

Displacement controls:

ES - Electric motor displacement control

HG - Handwheel displacement control

FE - Screw adjustment control

SP - Displacement proportional to electric signal

DP - Displacement proportional to pressure signal

Typical Section of Transmission Pump

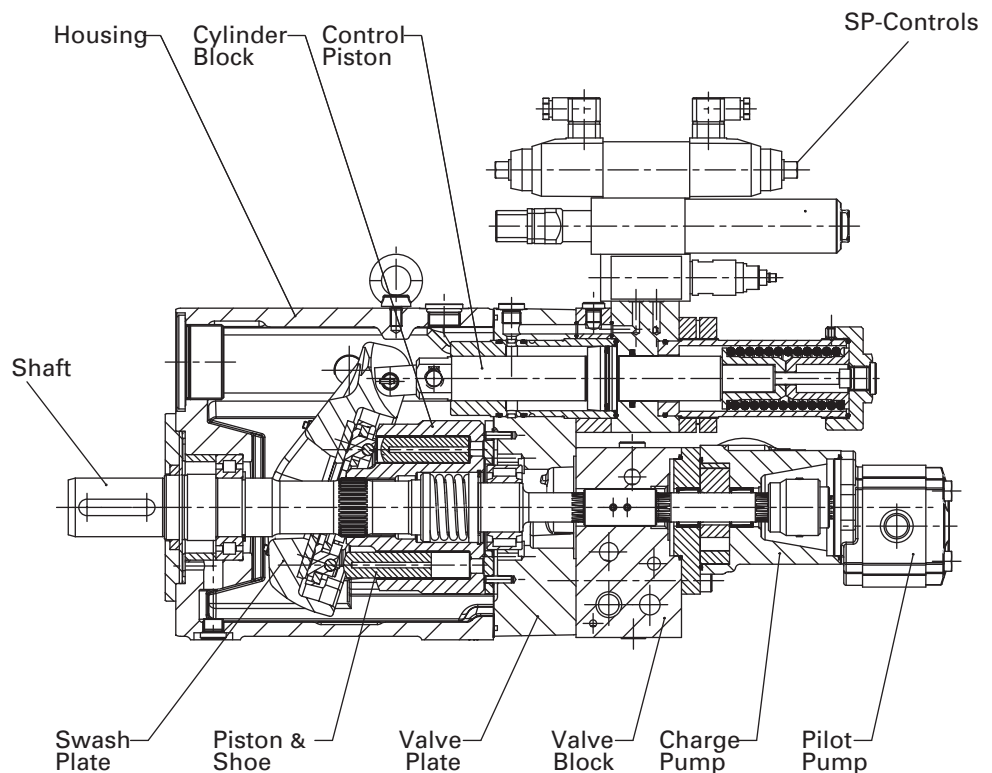

Dimensional information listed in this catalog is subject to change without notice.

Model Code

Transmission Pumps

"X" Series - ES Control

E S * 0 0 * 0 0 0 0 0 0 0 0 0 0 * * * * * * * #
 [28] [29] [30] [31] [32] [33] [34] [35] [36] [37] [38] [39] [40] [41] [42] [43] [44] [45] [46] [47] [48] [49] [50] [51]

[28] [29] Control type

ES – Electric motor displacement control

[30] Displacement Adjustment Options

M – Electric Motor - fast response
N – Electric Motor - medium response
P – Electric Motor - slow response

[31] [32] Electronic Controls

00 – Not required

[33] Yoke Displacement Zone

A – Single side of center "A"
C – Over center

[34] Extra Functions

0 – Not available

[35] Pressure Control Options

0 – Not applicable

[36] [37] [38] [39] [40] [41] Power

Control Options

000000 – Not applicable

[42] Pilot Oil Filter

0 – Not required

[43] Fail Safe Valve

0 – Not required

[44] Position Monitoring

A – 4 limit switches
B – 8 limit switches
P – 4 limit switches + sensor
T – 8 limit switches + sensor

[45] Electric Motor Type

2 – Motor with brake (IP54)
3 – Motor without brake (explosion proof)

[46] Control Voltage of Zero Position Valve

0 – Not applicable
B – 110 AC 50 Hz/
 120 AC 60 Hz
D – 220 AC 50 Hz/
 240 AC 60 Hz
G – 12 VDC
H – 24 VDC

[47] [48] [49] [50] Customer Adjustment Specification

0000 - None

???? - Yes (Final number will be assigned by Eaton. Specify on table below)

[51] Special Features

Add special feature description (characters 51..55) on page 12 if required

Theoretical Response Time (sec) for Zero to Maximum Displacement

SIZE	066/90	130/180	250
f Hz	50	60	50
Fast	7	6	18
Medium	24	20	35
Slow	38	432	54

CUSTOMER ADJUSTMENT SPECIFICATIONS	UNIT	STD. SETTING	CUSTOMER ADJUSTMENT OPTION	REMARKS
All Revolution Adjustments below set at ...	rpm	1500	–	
Pressure Relief Valve Side A	bar	350		
Pressure Relief Valve Side B	bar	350		
Charge Pressure Relief Valve - Size 066 & 090	bar	10	–	
Charge Pressure Relief Valve - Size 130 & 180	bar	13	–	
Charge Pressure Relief Valve - Size 250	bar	20	–	
Flushing (Low) Pressure Relief Valve - Size 066 & 090	bar	5	–	
Flushing (Low) Pressure Relief Valve - Size 130 & 180	bar	7	–	
Flushing (Low) Pressure Relief Valve - Size 250	bar	10	–	
Pilot Pressure	bar	60	–	
Mechanical Adjustment Stop Side A	L/min	Q _{max}		
Mechanical Adjustment Stop Side B	L/min	Q _{min}		
Displacement Adjusted to ...	L/min	-50% Q _{max} Side A		
Position Monitoring Switch 1	L/min	0 from A		
Position Monitoring Switch 2	L/min	95% Q _{max} Side A		> 95% not possible
Position Monitoring Switch 3	L/min	0 from B		
Position Monitoring Switch 4	L/min	95% Q _{max} Side B		> 95% not possible
Position Monitoring Switch 5	L/min	–		
Position Monitoring Switch 6	L/min	–		
Position Monitoring Switch 7	L/min	–		
Position Monitoring Switch 8	L/min	–		

Pressure Override Side A & B deleted

Model Code

Transmission Pumps

"X" Series - HG Control

H G 0 0 0 * 0 0 0 0 0 0 0 0 0 0 0 0 0 * * * * #

28 29 30 31 32 33 34 35 36 37 38 39 40 41 42 43 44 45 46 47 48 49 50 51

28 29 Control type

HG – Hand wheel displacement control

30 Displacement Adjustment Options

0 – Not applicable

31 32 Electronic Controls

00 – Not required

33 Yoke Displacement Zone

A – Single side of center "A"
C – Over center

34 Extra Functions

0 – Not available

35 Pressure Control Options

0 – Not applicable

36 37 38 39 40 41 Power Control Options

00000 – Not applicable

42 Pilot Oil Filter

0 – Not required

43 Fail Safe Valve

0 – Not required

44 Position Monitoring

0 – Not position monitoring

45 Electric Motor Type

0 – No electric motor

46 Control Voltage of Zero Position Valve

0 – Not applicable

47 48 49 50 Customer Adjustment Specification

0000 - None

???? - Yes (Final number will be assigned by Eaton. Specify on table below)

51 Special Features

Add special feature description (characters 51..55) on page 12 if required

CUSTOMER ADJUSTMENT SPECIFICATIONS	UNIT	STANDARD SETTING	CUSTOMER ADJUSTMENT OPTION	REMARKS
All Revolution Adjustments below set at ...	rpm	1500	–	–
Pressure Relief Valve Side A	bar	350		
Pressure Relief Valve Side B	bar	350		
Charge Pressure Relief Valve - Size 066 & 090	bar	10	–	
Charge Pressure Relief Valve - Size 130 & 180	bar	13	–	
Charge Pressure Relief Valve - Size 250	bar	20	–	
Flushing (Low) Pressure Relief Valve - Size 066 & 090	bar	5	–	
Flushing (Low) Pressure Relief Valve - Size 130 & 180	bar	7	–	
Flushing (Low) Pressure Relief Valve - Size 250	bar	10	–	
Displacement Adjusted to...	L/min	Q _{max} Side A		

Model Code

Transmission Pumps

"X" Series - FE Control

F E 0 0 0 * 0 0 0 0 0 0 0 0 0 0 0 0 * * * * #

28 29 30 31 32 33 34 35 36 37 38 39 40 41 42 43 44 45 46 47 48 49 50 51

28 29 Control type

FE – Screw adjusted displacement control

30 Displacement Adjustment Options

0 – Not applicable

31 32 Electronic Controls

00 – Not required

33 Yoke Displacement Zone

A – Single side of center "A"
C – Over center

34 Extra Functions

0 – Not available

35 Pressure Control Options

0 – Not applicable

36 37 38 39 40 41 Power Control Options

00000 – Not applicable

42 Pilot Oil Filter

0 – Not required

43 Fail Safe Valve

0 – Not required

44 Position Monitoring

0 – No position monitoring

45 Electric Motor Type

0 – No electric motor

46 Control Voltage of Zero Position Valve

0 – Not applicable

47 48 49 50 Customer Adjustment Specification

0000 - None

???? - Yes (Final number will be assigned by Eaton. Specify on table below)

51 Special Features

Add special feature description (characters 51...55) on page 12 if required

CUSTOMER ADJUSTMENT SPECIFICATIONS	UNIT	STANDARD SETTING	CUSTOMER ADJUSTMENT OPTION	REMARKS
All Revolution Adjustments below set at ...	rpm	1500	–	–
Pressure Relief Valve Side A	bar	350		
Pressure Relief Valve Side B	bar	350		
Charge Pressure Relief Valve - Size 066 & 090	bar	10	–	
Charge Pressure Relief Valve - Size 130 & 180	bar	13	–	
Charge Pressure Relief Valve - Size 250	bar	20	–	
Flushing (Low) Pressure Relief Valve - Size 066 & 090	bar	5	–	
Flushing (Low) Pressure Relief Valve - Size 130 & 180	bar	7	–	
Flushing (Low) Pressure Relief Valve - Size 250	bar	10	–	
Displacement Adjusted to...	L/min	Q _{max} Side A		

Model Code

Transmission Pumps

"X" Series - DP Control

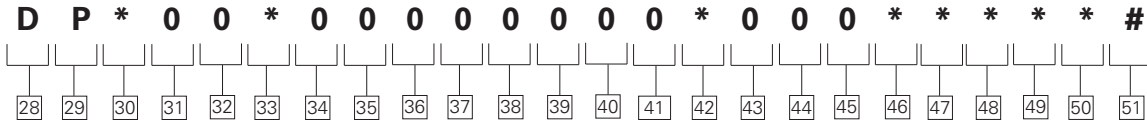

28 29 Control type

DP – Pressure signal displacement control

30 Displacement Adjustment Options

- G** – Mounting interface Cetop 3 only
- H** – Remote port G 1/4
- J** – Proportional relief inc. electronics
- K** – Proportional relief inc. electronics & displacement control

31 32 Electronic Controls

00 – Not required

33 Yoke Displacement Zone

- A** – Single side of center "A"
- C** – Over center

34 Extra Functions

0 – Not available

35 Pressure Control Options

0 – Not applicable

36 37 38 39 40 41 Power

Control Options
000000 – Not applicable

42 Pilot Oil Filter

- 0** – Not required
- V** – Filter with visual indicator
- E** – Filter with electronic indicator

43 Fail Safe Valve

0 – Not required

44 Position Monitoring

0 – No position monitoring

45 Electric Motor Type

0 – No electric motor

46 Control Voltage of Zero Position Valve

- 0** – Not applicable
- B** – 110 AC 50 Hz/
120 AC 60 Hz
- D** – 220 AC 50 Hz/
240 AC 60 Hz
- G** – 12 VDC
- H** – 24 VDC

47 48 49 50 Customer Adjustment Specification

0000 - None

???? - Yes (Final number will be assigned by Eaton. Specify on table below)

51 Special Features

Add special feature description (characters 51...55) on page 12 if required

CUSTOMER ADJUSTMENT SPECIFICATIONS	UNIT	STANDARD SETTING	CUSTOMER ADJUSTMENT OPTION	REMARKS
All Revolution Adjustments below set at ...	rpm	1500	–	–
Pressure Relief Valve Side A	bar	350		
Pressure Relief Valve Side B	bar	350		
Charge Pressure Relief Valve - Size 066 & 090	bar	10	–	
Charge Pressure Relief Valve - Size 130 & 180	bar	13	–	
Charge Pressure Relief Valve - Size 250	bar	20	–	
Flushing (Low) Pressure Relief Valve - Size 066 & 090	bar	5	–	
Flushing (Low) Pressure Relief Valve - Size 130 & 180	bar	7	–	
Flushing (Low) Pressure Relief Valve - Size 250	bar	10	–	
Pilot Pressure	bar	60	–	
Mechanical Adjustment Stop Side A	L/min	Q _{max}		
Mechanical Adjustment Stop Side B	L/min	Q _{min}		

Model Code

Transmission Pumps

"X" Series - SP Control

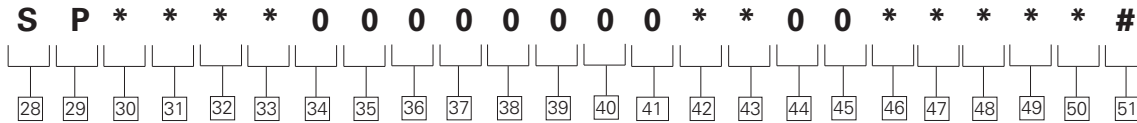

28 29 Control type

SP – Proportional Valve Displacement Control

30 Displacement

Adjustment Options

C – With Cetop 3 Proportional valve KDG4V 3
F – With Cetop 5 Proportional valve

31 32 Electronic Controls

00 – Not required
03 – ER 9.3 - 10 (Cetop 3)
04 – ER 9.4 - 10 (Cetop 5)

33 Yoke Displacement Zone

A – Single side of center "A"
C – Over center

34 Extra Functions

0 – Not required

35 Pressure Control

Options

0 – Not applicable

36 37 38 39 40 41 Power

Control Options

000000 – Not applicable

42 Pilot Oil Filter

0 – Not required
V – Filter with visual indicator
E – Filter with electronic indicator

43 Fail Safe Valve

0 – Not required
1 – With solenoid valve

44 Position Monitoring

0 – No position monitoring

45 Electric Motor Type

0 – No electric motor

46 Control Voltage of Zero Position Valve

0 – Not applicable
B – 110 AC 50 Hz/
 120 AC 60 Hz
D – 220 AC 50 Hz/
 240 AC 60 Hz
G – 12 VDC
H – 24 VDC

47 48 49 50 Customer Adjustment Specification

0000 – None

???? – Yes (Final number will be assigned by Eaton. Specify on table below)

51 Special Features

Add special feature description (characters 51..55) on page 12 if required

CUSTOMER ADJUSTMENT SPECIFICATIONS	UNIT	STD. SETTING	CUSTOMER ADJUSTMENT OPTION	REMARKS
All Revolution Adjustments below set at ...	rpm	1500	–	–
Pressure Relief Valve Side A	bar	350		
Pressure Relief Valve Side B	bar	350		
Charge Pressure Relief Valve - Size 066 & 090	bar	10	–	
Charge Pressure Relief Valve - Size 130 & 180	bar	13	–	
Charge Pressure Relief Valve - Size 250	bar	20	–	
Flushing (Low) Pressure Relief Valve - Size 066 & 090	bar	5	–	
Flushing (Low) Pressure Relief Valve - Size 130 & 180	bar	7	–	
Flushing (Low) Pressure Relief Valve - Size 250	bar	10	–	
Pilot Pressure	bar	60	–	
Mechanical Adjustment Stop Side A	L/min	Q_{max}		
Mechanical Adjustment Stop Side B	L/min	Q_{min}		
Max. Stop by Control Side A	L/min	95% Q_{max}	El. Card Adjustment Done by Customer	Refer to El. card manual
Max. Stop by Control Side B	L/min	95% Q_{max}	El. Card Adjustment Done by Customer	Refer to El. card manual
Ramp Time 0 _ A For 100% Stroke	sec	0	El. Card Adjustment Done by Customer	Refer to El. card manual
Ramp Time A _ 0	sec	0	El. Card Adjustment Done by Customer	Refer to El. card manual
Preset Input Signals S1 ... S4	L/min	–	El. Card Adjustment Done by Customer	Refer to El. card manual

Model Code

Transmission Pumps

"X" Series -
Special Features

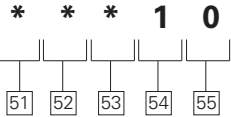

51 52 53 **Special Features**

- 000 – None
- *** – Defined by Eaton

54 55 **Design Number**

- 10 – Design Number

Model Code

Combination Units

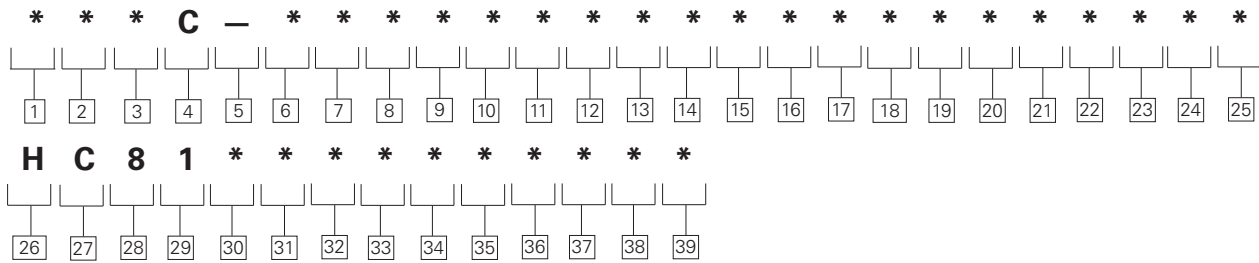

1 Combination Unit

- P** – Pump
- T** – Transmission Pump
- M** – Motor

2 Displacement

- F** – Filled
- V** – Variable

3 Pump Series

- W** – “W” Series
(was 30 design)
- X** – “X” Series
(was 20 design)

4 Combination Unit

C

5 Separator

6 7 8 First

Displacement cm³/r

- 066** – 66 cm³/r [4.0 in³/rev]
- 090** – 90 cm³/r [5.5 in³/rev]
- 130** – 130 cm³/r [7.9 in³/rev]
- 180** – 180 cm³/r [11.0 in³/rev]
- 250** – 250 cm³/r [15.3 in³/rev]
- 360** – 360 cm³/r [22.0 in³/rev]
- 500** – 500 cm³/r [30.5 in³/rev]
- 750** – 750 cm³/r [45.8 in³/rev]

9 10 First Control Type

- 00** – No Control (for Fixed Displacement Only)
- DF** – Pressure Compensator
- LR** – Power Control
- ES** – Electric Motor Control
- HG** – Handwheel
Displacement Control
- FE** – Screw Adjustment
Displacement Control
- SM** – Servo Adjustment
Displacement Control -
Mech Feedback
- DP** – Pressure Signal
Displacement Control
- SP** – Proportional Valve
Displacement Control

11 12 13 Second

Displacement cm³/r

- 066** – 66 cm³/r [4.0 in³/rev]
- 090** – 90 cm³/r [5.5 in³/rev]
- 130** – 130 cm³/r [7.9 in³/rev]
- 180** – 180 cm³/r [11.0 in³/rev]
- 250** – 250 cm³/r [15.3 in³/rev]
- 360** – 360 cm³/r [22.0 in³/rev]
- 500** – 500 cm³/r [30.5 in³/rev]
- 750** – 750 cm³/r [45.8 in³/rev]

14 15 Second Control Type

- 00** – No Control (for Fixed Displacement Only)
- DF** – Pressure Compensator
- LR** – Power Control
- ES** – Electric Motor Control
- HG** – Handwheel
Displacement Control
- FE** – Screw Adjustment
Displacement Control
- SM** – Servo Adjustment
Displacement Control -
Mech Feedback
- DP** – Pressure Signal
Displacement Control
- SP** – Proportional Valve
Displacement Control

16 17 18 Third

Displacement cm³/r

- 000** – Not Required
- 066** – 66 cm³/r [4.0 in³/rev]
- 090** – 90 cm³/r [5.5 in³/rev]
- 130** – 130 cm³/r [7.9 in³/rev]
- 180** – 180 cm³/r [11.0 in³/rev]
- 250** – 250 cm³/r [15.3 in³/rev]
- 360** – 360 cm³/r [22.0 in³/rev]
- 500** – 500 cm³/r [30.5 in³/rev]
- 750** – 750 cm³/r [45.8 in³/rev]

19 20 Third Control Type

- 00** – No Control (for Fixed Displacement Only)
- DF** – Pressure Compensator
- LR** – Power Control
- ES** – Electric Motor Control
- HG** – Handwheel
Displacement Control
- FE** – Screw Adjustment
Displacement Control
- SM** – Servo Adjustment
Displacement Control -
Mech Feedback
- DP** – Pressure Signal
Displacement Control
- SP** – Proportional Valve
Displacement Control

21 22 23 Fourth Displacement cm³/r

- 000** – Not Required
- 066** – 66 cm³/r [4.0 in³/rev]
- 090** – 90 cm³/r [5.5 in³/rev]
- 130** – 130 cm³/r [7.9 in³/rev]
- 180** – 180 cm³/r [11.0 in³/rev]
- 250** – 250 cm³/r [15.3 in³/rev]
- 360** – 360 cm³/r [22.0 in³/rev]
- 500** – 500 cm³/r [30.5 in³/rev]
- 750** – 750 cm³/r [45.8 in³/rev]

- For a combination of two or more units fill out this Combination Model Code.
- Start with the biggest size unit for the first displacement.
- For each unit included in this combination, a separate model code must be chosen. Use the form on page 5.
- Character 26 to 39 will be P/N of the combination. This number will be defined by Eaton and provided in the order acknowledgement.

24 25 Fourth Control Type

- 00** – No Control (for Fixed Displacement Only)
- DF** – Pressure Compensator
- LR** – Power Control
- ES** – Electric Motor Control
- HG** – Handwheel
Displacement Control
- FE** – Screw Adjustment
Displacement Control
- SM** – Servo Adjustment
Displacement Control -
Mech Feedback
- DP** – Pressure Signal
Displacement Control
- SP** – Proportional Valve
Displacement Control

26 27 28 29 Assembly Numbers

HC81 – Defined By Eaton

30 31 32 33 34 35 36 37 38 39 Assembly Numbers

Defined By Eaton

- Charge and Pilot Pump through drive option must be specified on the rear unit of the combination (as a special feature).
- Front and middle units shall have the through drive option of the following unit in the combination.

Model Code

Examples for
Combination Units

Example 1: Combination of two closed loop pumps

Model Code Front Unit	TVWF-500M08R0000H1R02SVMA20SPC03C00000000E100H000000010
Model Code Rear Unit	TVXR-066M02R000001R02SVMA00SPC03C00000000E000H000000010
Model Code Combination Unit	TVWC-500SP0660SP0000000000HC81*****

Example 2: Combination of one closed loop - and two open loop pumps (For open loop model code refer to the according catalog)

Mode Code Front Unit	TVWF-500M08R0000H1R02SVMA20SPC03C00000000E100H000000010
Model Code Middle Unit	PVWM-250M07R00E1R02SV0ADF00A0000000000000000010
Model Code Rear Unit	PFXR-130M02R00P1A02SV0A00000A0000000000000000010
Model Code Combination Unit	TVWC-500SP250DF1300000000HC81*****

Pump Specifications - US

MODEL			TVX 066	TVX 090	TVX 130	TVX 180	TVX 250
Design			Swashplate - Axial piston pump				
Type of mounting			Flange or foot-mounted. Combination units foot mounted only				
Pipe connection SAE/Flange	B A	psi	1" = 6000 1" = 6000	1" = 6000 1" = 6000	1" = 6000 1" = 6000	1" = 6000 1" = 6000	1" = 6000 1" = 6000
Direction of rotation			Clockwise when viewing shaft end of pump Counterclockwise available on request				
Speed range	n _{min} n _{max}	rpm	150 1800				
Installation position			Optional, see mounting information				
Ambient temperature range	min max	°F	-4 122				
Weight	m	lb	168	168	348	379	540
Mass of inertia	J	lb ft ²	0.38	0.38	1.068	1.068	3.456

HYDRAULIC CHARACTERISTICS

Nominal pressure (100% duty cycle)	p _N	psi	5000				
Input pressure	p _{1min} p _{1max}	psi	12.5 abs Pressure can be applied to the pump inlet but the sum of p ₁ and p ₂ must not exceed the maximum value of 6090psi)				
Maximum pressure to DIN 24312	p _{2max}	psi	6090				
Hydraulic fluid			Hydraulic oil to DIN 51524 part 2. Refer to section Application Data-Fluid Recommendations				
Hydraulic fluid temperature range	min max	°F	-13 on startup 194				
Viscosity range for continuous operation	min max	cSt cSt	10 75				
Maximum permissible start viscosity	max	cSt	1000				
Filtering	ISO 4406		18/15/13				
Maximum geometric displacement	V _g	in ³	66	90	130	180	250
Maximum geometric pump flow	n= 1500 rpm n= 1800 rpm	Q _g USgpm	28 32	36 43	52 62	71 86	99 119
Case pressure	p _{v max}	psi	max 7.2psi over p _A , p _B				

HYDRAULIC CHARACTERISTIC OF CHARGE AND PILOT PUMP

Displacement charge pump	V _{g Sp}	in ³	0.97	1.4	2.01	2.44	3.91
Charge pressure	p _{N Sp}	psi	73/145	73/145	102/189	102/189	145/290
Input pressure charge & pilot pump	p _{min Sp/St}	psi	11.6 absolute				
Displacement pilot pump	V _{g St}	in ³	0.5				
Pilot pressure	p _{St}	psi	870	870	870	870	870

DRIVE

Maximum driving torque - single unit (p _{2 max} , η= 100%)	M _{1 Single}	lb.ft.	325	443	640	887	1243
Maximum power consumption - single unit (p _{2 max} , η= 100%; n= 1800 rpm)	P _{1 Single}	hp	93	126	182	254	355
Max. driving torque - comb. unit	M _{1 Comb.}	lb.ft.	2x325	2x443	2x643	2x890	2x1248

1) TVW - 750 at 1800 rpm reduced to 38.1 in³

2) When pressure below 1450psi and flow below 25% of maximum flow

Pump Specifications - Metric

MODEL			TVX 066	TVX 090	TVX 130	TVX 180	TVX 250
Design			Swashplate - Axial piston pump				
Type of mounting			Flange or foot-mounted. Combination units foot mounted only				
Pipe connection SAE/Flange	B A	psi	1" = 6000 1" = 6000	1" = 6000 1" = 6000	1" = 6000 1" = 6000	1" = 6000 1" = 6000	1" = 6000 1" = 6000
Direction of rotation			Clockwise when viewing shaft end of pump Counterclockwise available on request				
Speed range	n_{min} n_{max}	min^{-1}	150 1800				
Installation position			Optional, see mounting information				
Ambient temperature range	min max	°C	-20 50				
Weight	m	kg	76	76	138	172	245
Mass of inertia	J	kg m ²	0.016	0.016	0.045	0.045	0.146

HYDRAULIC CHARACTERISTICS

Nominal pressure (100% duty cycle)	p_N	bar	5000 (350)				
Input pressure	p_{1min} p_{1max}	bar bar	4 abs Pressure can be applied to the pump inlet but the sum of p_1 and p_2 must not exceed the maximum value of 420 bar				
Maximum pressure to DIN 24312	p_{2max}	bar	420				
Hydraulic fluid			Hydraulic oil to DIN 51524 part 2. Refer to section Application Data-Fluid Recommendations				
Hydraulic fluid temperature range	min max	°C	-25 on startup 90				
Viscosity range for continuous operation	min max	cSt cSt	10 75				
Maximum permissible start viscosity	max	cSt	1000				
Filtering	ISO 4406		18/15/13				
Maximum geometric displacement	V_g	cm ³	4.03	5.49	7.93	10.98	15.26
Maximum geometric pump flow	Q_g	$n = 1500 \text{ min}^{-1}$ $n = 1800 \text{ min}^{-1}$	99 118	135 162	195 234	270 324	375 450
Case pressure	$p_{v \max}$	bar	max 7.2psi (0.5 bar) over air pressure p_A, p_B				

HYDRAULIC CHARACTERISTIC OF CHARGE AND PILOT PUMP

Displacement charge pump	$V_{g \ Sp}$	cm ³	16	23	33	40	64
Charge pressure	$p_{N \ Sp}$	bar	5/10	5/10	7/13	7/13	10/20
Input pressure charge & pilot pump	$p_{min \ Sp/St}$	bar	0,8 absolute				
Displacement pilot pump	$V_{g \ St}$	cm ³	8				
Pilot pressure	p_{St}	bar	60	60	60	60	60

DRIVE

Maximum driving torque - single unit ($p_{2 \ max}, \eta = 100\%$)	$M_{1 \ Single}$	Nm	440	600	868	1202	1685
Maximum power consumption - single unit ($p_{2 \ max}, \eta = 100\%; n = 1800 \text{ min}^{-1}$)	$P_{1 \ Single}$	kW	69	94	136	189	265
Maximum driving torque - comb. unit	$M_{1 \ Comb.}$	Nm	2x440	2x600	2x868	2x1202	2x1685

1) TVW - 750 at 1800 min⁻¹ reduced to 625cm³

2) When pressure below 100 bar and flow below 25% of maximum flow

Performance Curves - 066, 090, 130, 180, 250 Series

Outlet Flow and Theoretical Power Consumption

Typical at 1500 min⁻¹ with anti-wear oil at 40 cSt
Single displacement pumps: PFX,PVX

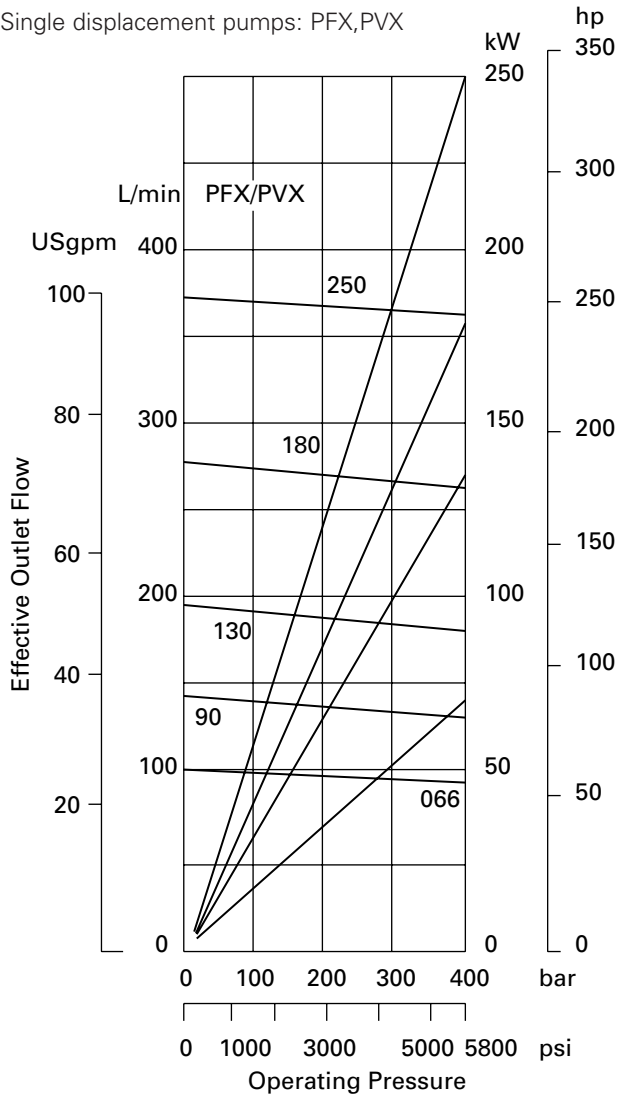

Combination units

For combination pumps the characteristic values are as for the individual units.

Volumetric and Overall Efficiencies

For Calculation: $P_{eff} = P_{th}/\eta_{tot}$

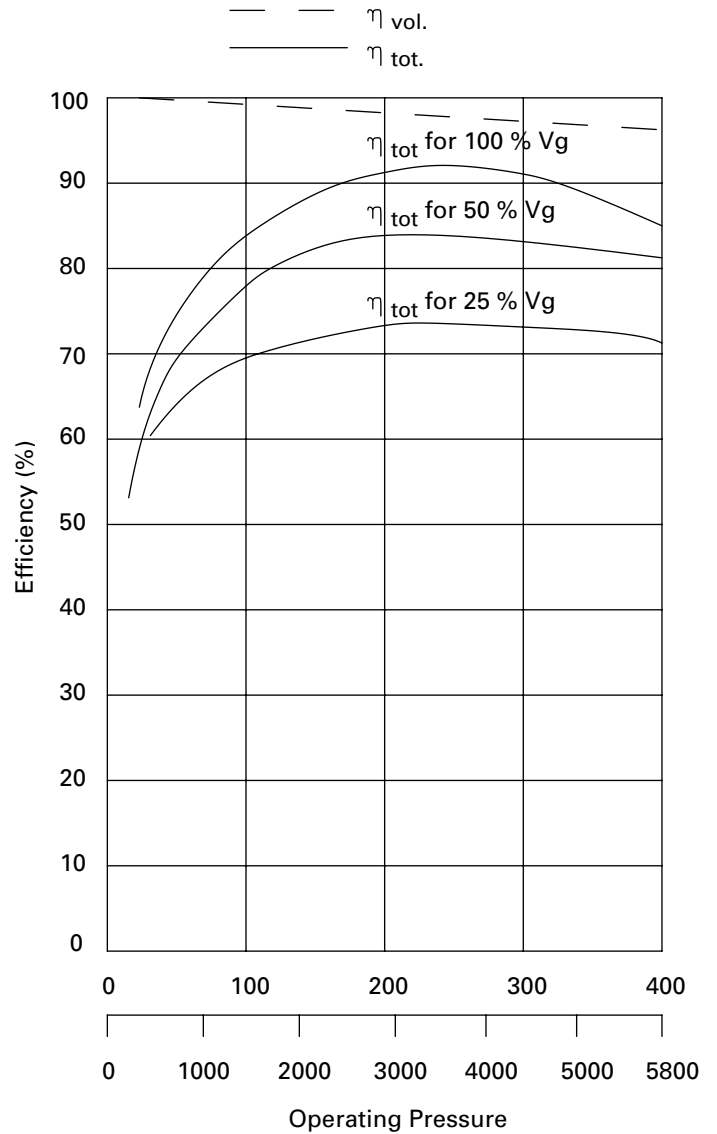

For reduced wash-angle:

$$L_h = (L \text{ at } V_{max}) \times \frac{1}{\left(\frac{V}{V_{max}}\right)^{\frac{10}{3}}}$$

Operating Data

066,090,130,180, 250 Series

Theoretical Bearing Life Time

At maximum displacement
and various speeds.

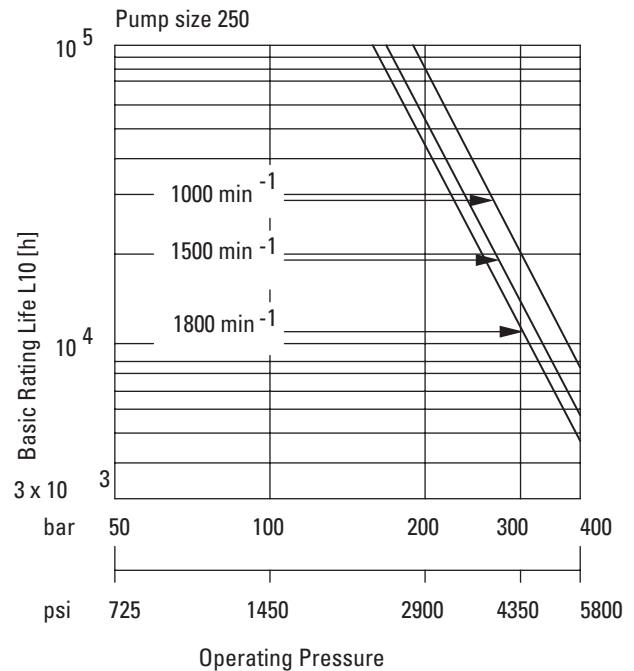
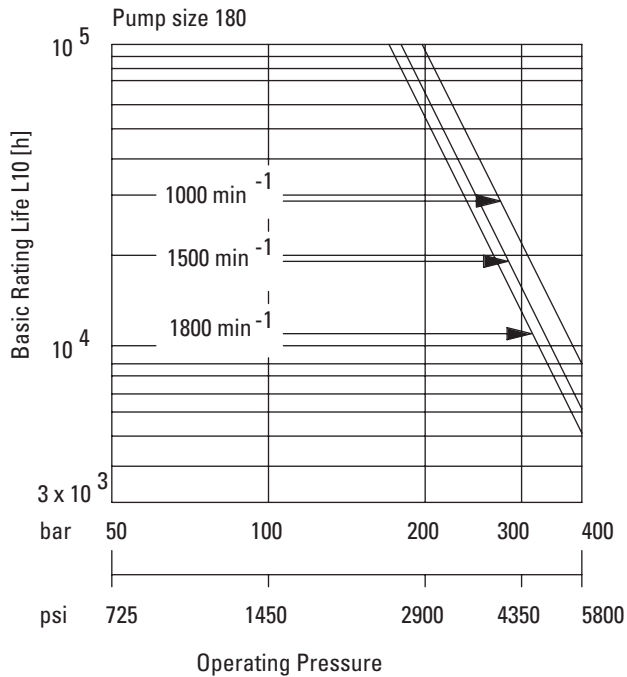
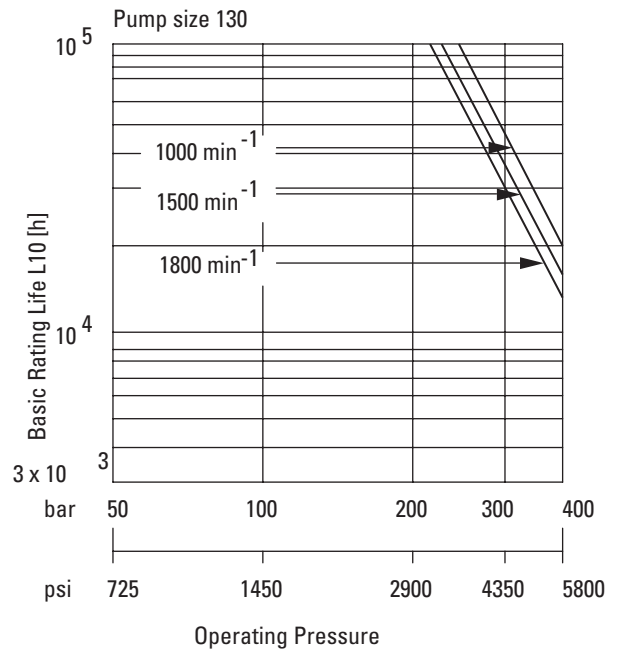
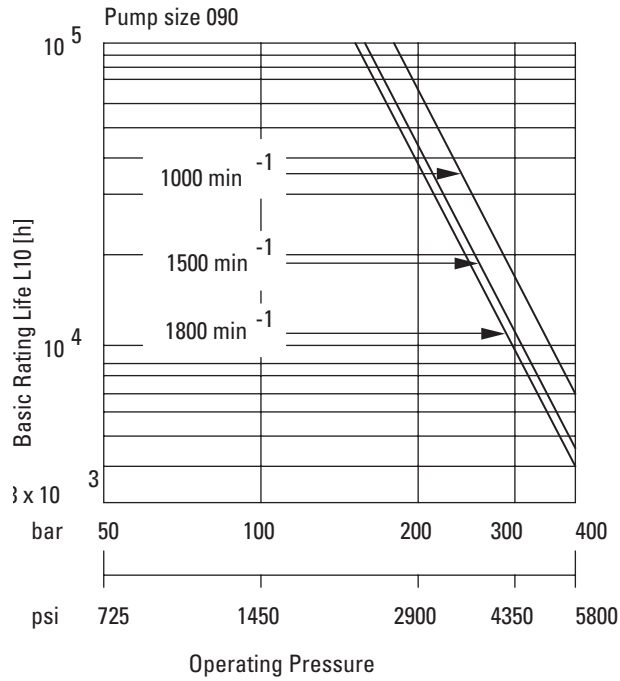
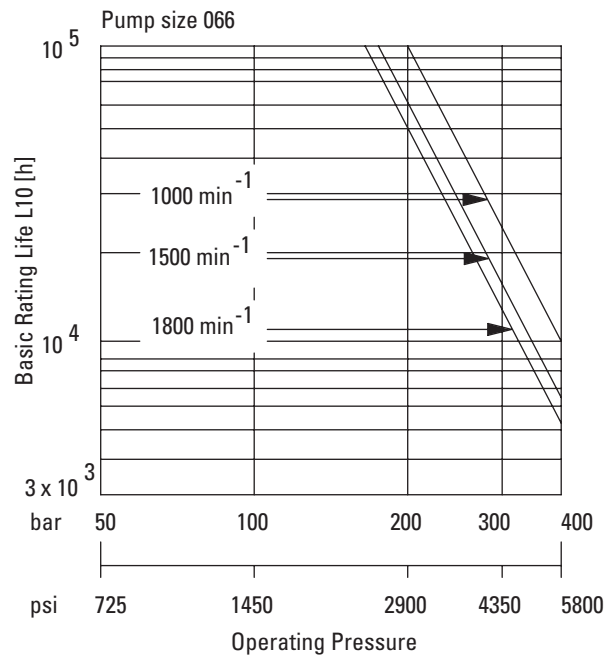

Hydraulic Transmission Circuit

"X" Series – Closed Loop

Example for a completed Hydraulic Transmission

Example shown is a complete drive for a slow speed conveyor belt, with TVX-pump and ES-control, with MF-motor and gearbox, integrated in a power unit.

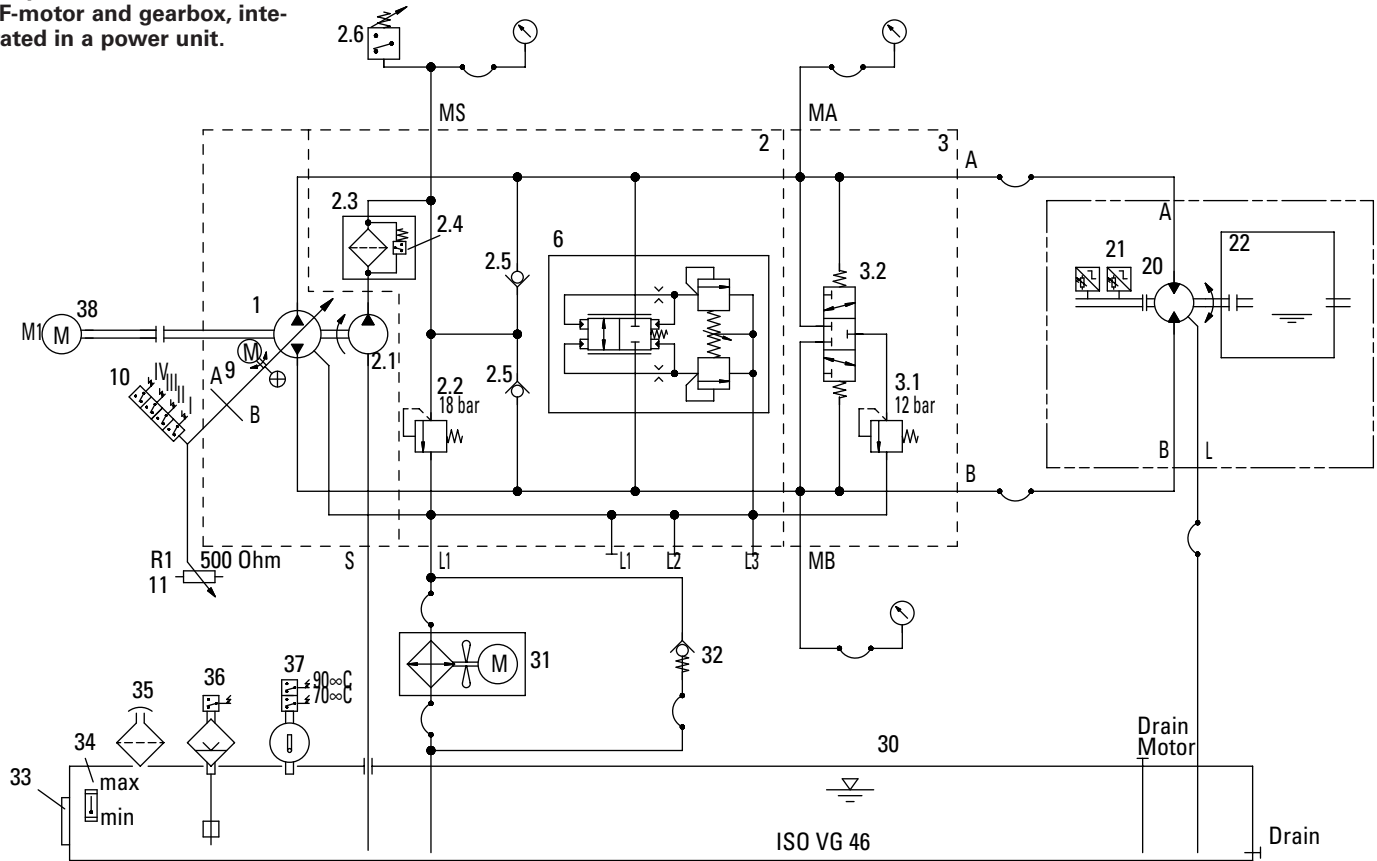

A, B	System port	2.2	Charge pressure relief valve	6	High pressure relief valve	33	Thermometer
L1, L2,	Drain port	2.3	Charge flow filter	9	Servo motor	34	Optical Level Indicator
L3	Oil filling plug	2.4	Clogging indicator for charge flow filter	10	Control limit switches	35	Venting Filter
MA, MB	Gauge port-system pressure	2.5	Charge check valves (2 pcs)	11	Control feedback potentiometer	36	Level switch
MS	Gauge port-charge pressure	2.6	Charge pressure relief switch	20	Motor MF	37	Temperature switch
S	Suction port for charge pump	3	Flushing block	21	Limit switches (speed control)	38	Electric motor
L	Drain port motor	3.1	Low pressure relief valve (replenishing valve)	22	Rearbox		
1	Basic pump	3.2	Flushing flow shuttle valve	30	Reservoir		
2	Charge block			31	Cooler Oil/Air		
2.1	Charge pump			32	Bypass - Valve		

FE, HG Manual Adjustment Displacement Control

"X" Series – Closed Loop

FE The FE-control is a displacement control where the pump flow is adjusted by a screw.

HG The HG-control is a displacement control where the pump flow can be adjusted by handwheel.

The maximum (and/or minimum) flow can be limited by a spacer inside the control cylinder (position no. 13 in modelcoding, options 4, 5 or 6 in combination with

customer adjustment speculation position 47-50 for the set values). The setting must be defined before ordering and cannot be modified during operation.

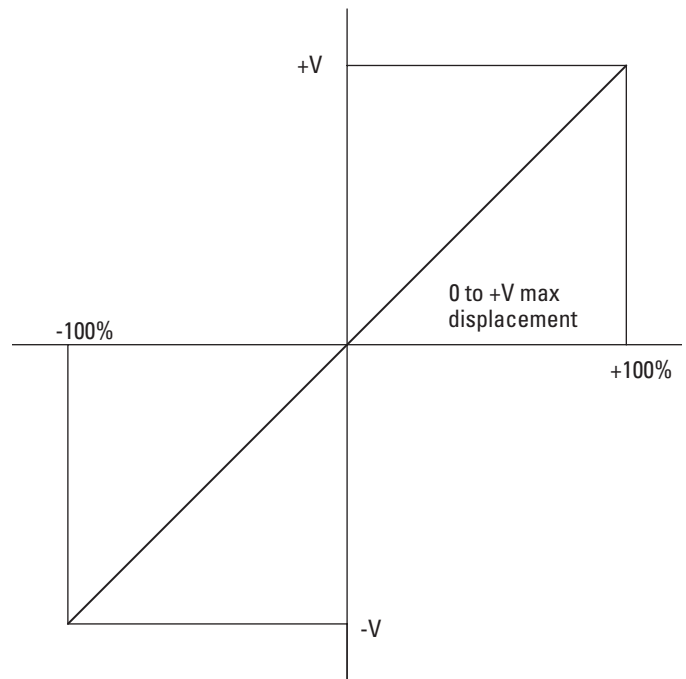
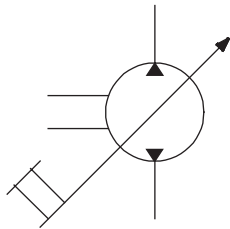

Electric Motor Displacement Control ES

"X" Series – Closed Loop

The unit is used for flow adjustment. It has a three phase electric servo motor, worm gearing and a switch box with 4 or (optional) 8 limit switches for different positions. A potentiometer is also available.

The response times from zero to maximum depends on the chosen ratio and the (fixed) speed of the servo motor (this means that once the control is defined and built the response times are not variable during operation).

No Pressure / Power Limiter possible!

Explosion protection versions are also available.

As an additional option the maximum (and/or minimum) flow can be limited by a spacer inside the control cylinder

(position no. 13 in model coding, options 4, 5 or 6 in combination with customer adjustment speculation position 47-50 for the set values). The setting must be defined before ordering and cannot be modified during operation.

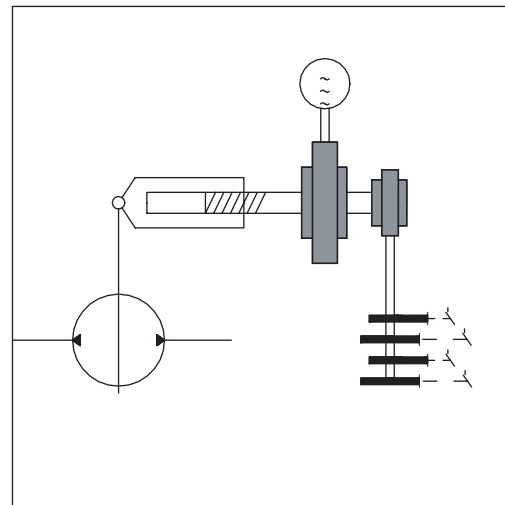
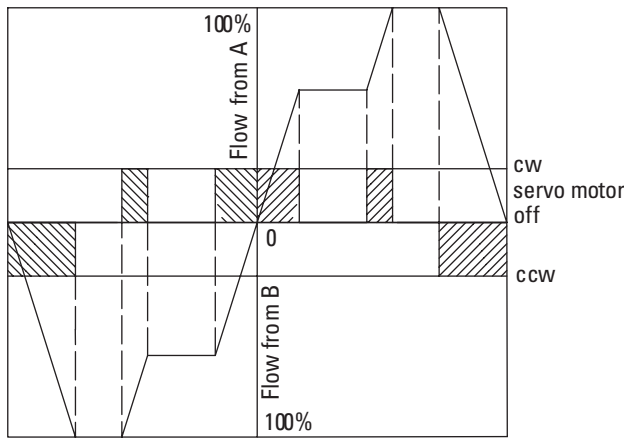

Response Time Table

THEORETICAL RESPONSE TIME (SEC) FOR MAXIMUM DISPLACEMENT CHARACTER IN MODEL CODE POS. 30

Size	066 / 090		130 / 180		250		
Freq. Hz	50	60	50	60	50	60	
Fast	7	6	18	15	15	13	M
Medium	24	20	35	29	30	25	N
Slow	38	32	54	45	48	40	P

Response time from 0 to +Qmax or 0 to - Qmax

Pressure Signal Displacement Control DP

"X" Series – Closed Loop

The output flow of the pump is proportional to the pilot pressure.

A separate pilot oil circuit is necessary.

From this, the control pressure is reduced to the desired set value by means of a suitable pressure control valve (with P-T line) and throttle in P-line 0.8 Ø (0.03 in).

To work in both directions, a solenoid valve is needed to switch the pilot flow from A to B (pos. 30 in model coding, option "K").

The DP-control can be used for stepless flow control with standard requirements for dynamic and precision.

No feedback signal is needed, an optical indicator recommended (pos. 24 in model coding, option "V").

A pilot oil filter can be mounted in-line between pump and control (pos. 42 in model coding, option "V" or "E").

Pressure limiter or power limiter override not available (for such and other options please refer to PVW-Series).

As an additional option the maximum (and/or minimum) flow can be limited by a spacer inside the control cylinder (position no.13 in model coding, options 4, 5 or 6 in combination with customer adjustment speculation position 47-50 for the set values). The setting must be defined before ordering and cannot be modified during operation.

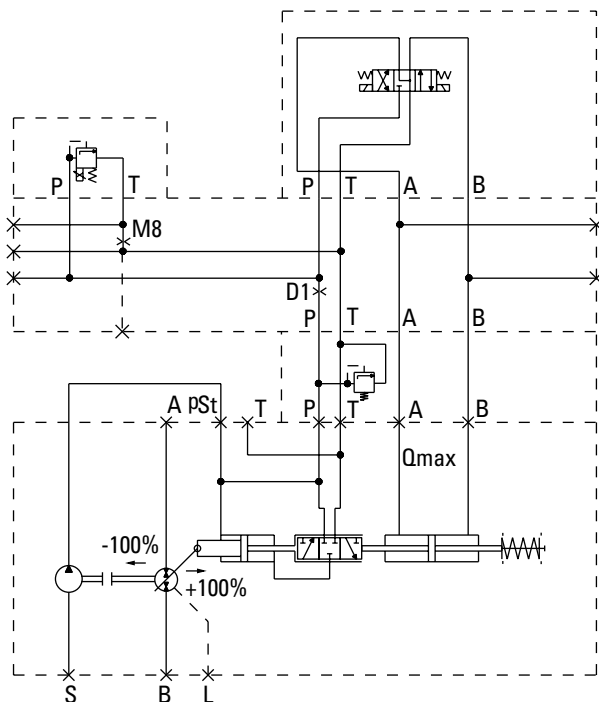

TVX Response Times DP - Control

SIZE	RESPONSE TIME (SEC) WITH 12 L/MIN PILOT OIL FLOW	
	(Standard)	Pilot Pressure pSt [bar]
066/090	0,7	60
130/180	0,9	60
250	1,1	60

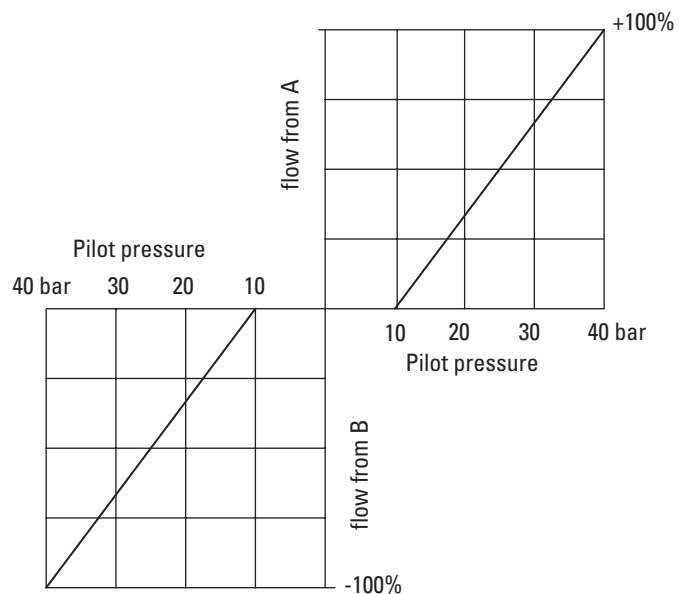

The output flow of the pump is proportional to the pilot pressure

Example for TVXS

DP Control

"X" Series – Closed Loop

The example shows a TVXS-130 pump with DP-control and complete transmission circuit, for over-center operation

(with solenoid valve 24V DC) with charge oil filter with electrical indicator, but without pilot oil filter.

Other model coding also possible due to some variations which cannot be seen in the circuit diagram (seal material, main drive shaft end).

Possible model coding for such pump:

TVXS-130M04R000TP1R01SVVA20DPK00C000000000000H000000010.

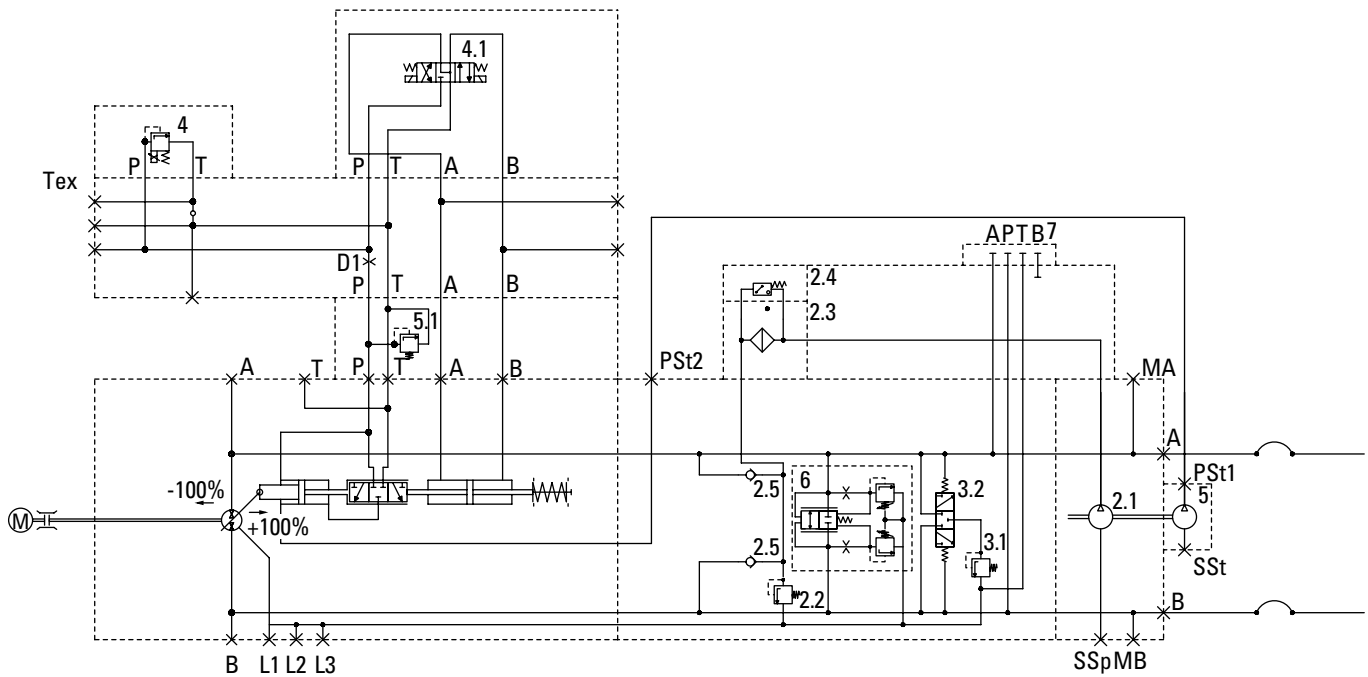

A, B	System ports	X1	Remote port control pressure	3.1	Low pressure relief valve	5	Pilot pump
L1, L2, L3	Drain ports	T	Return line control circuit	3.2	Flushing flow shuttle valve Tex return line proportional relief valve	5.1	Pilot pressure relief valve
MA, MB	Gauge port-system pressure	1	Basic pump	4	Proportional pressure relief valve	6	High pressure relief valve
SSp	Suction port for charge pump	2.1	Charge pump	4.1	Solenoid valve for directional control	7	Interface for short cut valve
SSSt	Suction port for pilot pump	2.2	Charge pressure relief valve				
pSt1	Outlet port pilot pump	2.3	Charge flow filter				
pSt2	Pilot pressure port	2.4	Clogging indicator for charge flow filter				
		2.5	Check valves (2 pcs)				

Proportional Valve Displacement Control SP

"X" Series – Closed Loop

The SP control operates a hydrostatic drive and works without throttle losses within electrically adjustable limits. This is done by controlling delivery flow with electrical swashplate angle feedback (electrical closed-loop control).

All control values are recorded as an electrical signal and lead back to the control card. The proportional valve and servo piston transform the output signal of the control card to the desired setting.

This results in a very precise and dynamic control.

Pressure limiter override available on request. Power limiter override not available (for such and other options please refer to TVW series).

As an additional option the maximum (and/or minimum) flow can be limited by a spacer inside the control cylinder (position no.13

in model coding, options 4, 5 or 6 in combination with customer adjustment speculation position 47-50 for the set values). The setting must be defined before ordering and cannot be modified during operation.

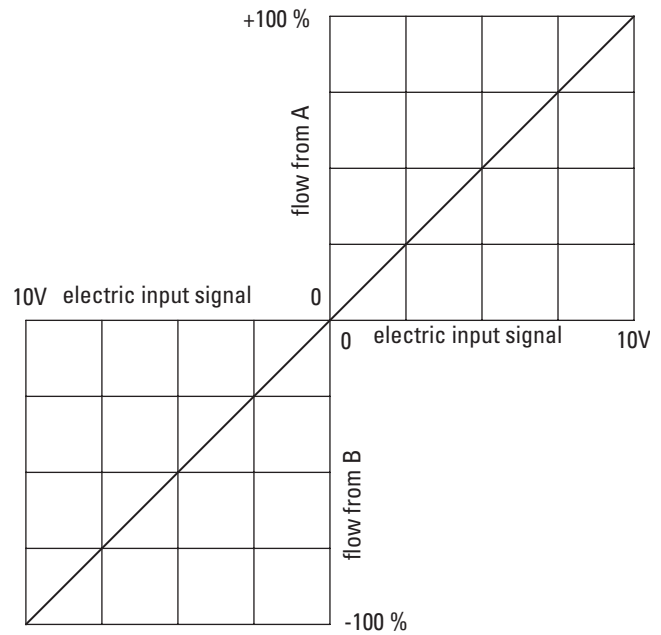
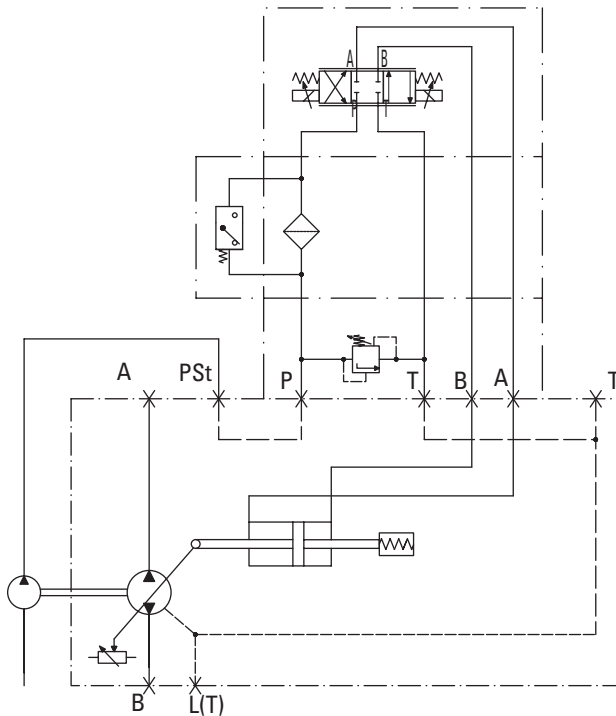

TVX Response Times SP - Control

PROPORTIONAL VALVE

	Pilot Oil Flow	Pilot Oil Pressure p_{St}	Control Electronics	Response Time	Unit Size	Servo Piston		
	L/min (USgpm)	bar (psi)	(Amp.card) bar (psi)	0 < > Vmax [ms]	cm ³	Diameter mm (in)	Stroke mm (in) one side	Volume cm ³ (in ³) per chamber
Medium response	12 (3.17)	60 (857)	ER 9.3-10	250	066 / 090	40/30 (1.57/1.18)	28 (1.10)	15,4 (0.939)
KDG4V3-2C20NMUH760 (CETOP 3)	12 (3.17)	60 (857)	ER 9.3-10	350	130 / 180	55/38 (2.16/1.49)	35 (1.37)	43,5 (2.654)
	12 (3.17)	60 (857)	ER 9.3-10	550	250	70/50 (2.76/1.97)	43,5 (1.71)	81 (4.942)

High response (CETOP 5)

ON REQUEST

The ER9.3-10 and ER 9.4-10 (for high response) digital amplifier cards are optimized for use with the SP-Control. Please ask for separate documentation. Software is available for parameter setting and storing (database function). Contact Eaton to request free of charge manual and software CD.

Example for TVXS

SP Control

"X" Series – Closed Loop

The example shows a TVXS-130 pump with SP-control, complete transmission circuit and pressure limiter override

for both sides, with charge and pilot oil filter with electrical indicator.

Other model coding also possible due to some variations which cannot be seen in the circuit diagram (seal material, main drive shaft end).

Note: the below shown pressure limiter override is not in standard model coding, but will be available on request.

Possible model coding for such pump:

TVXS-130M04R000TP1R01SVPA20SPC03C30000000E000000000010.

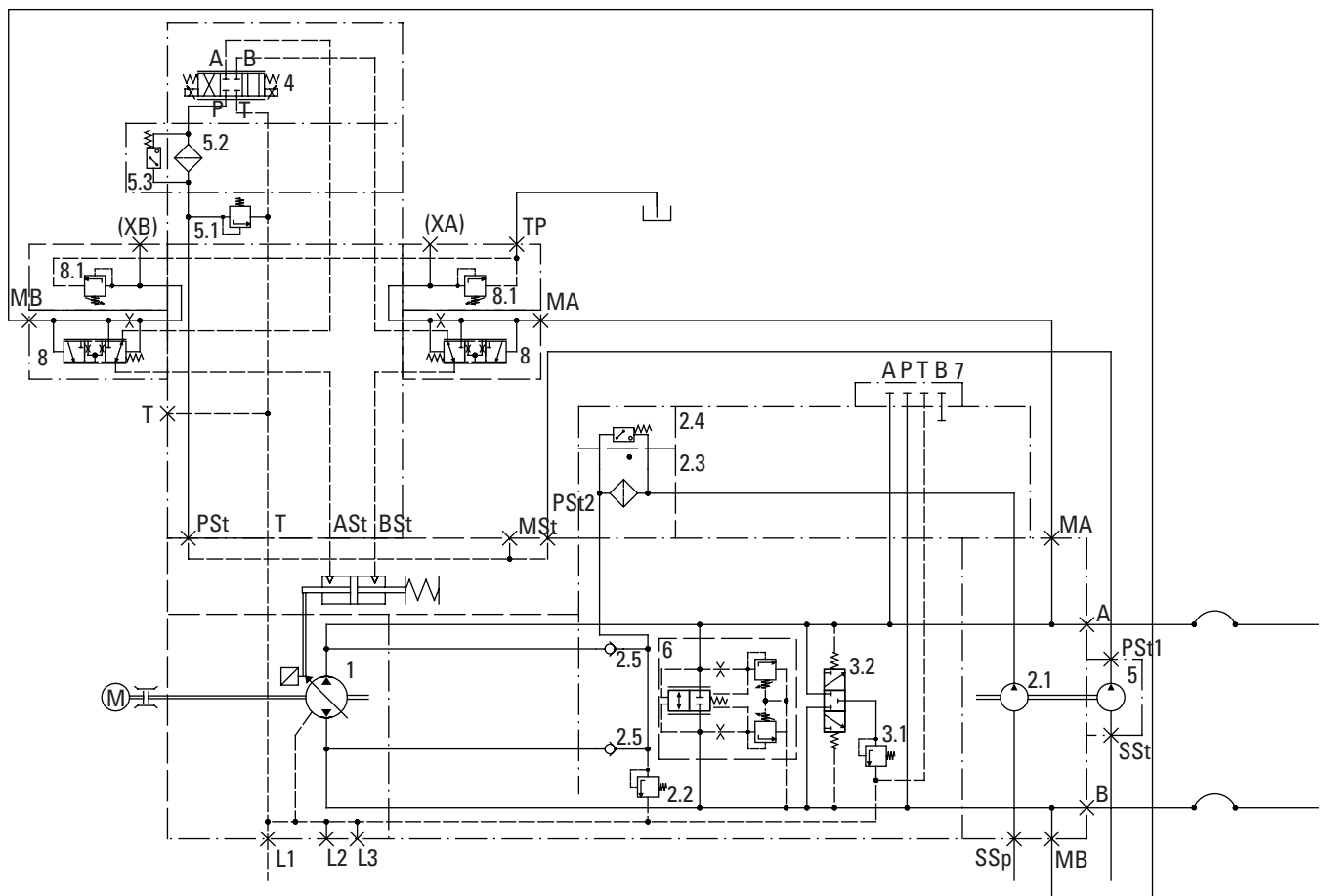

A, B	System ports	pSt2	Pilot pressure port	2.4	Clogging indicator for charge flow filter	5.2	Pilot oil filter
L1, L2, L3	Drain ports	T	Return line control circuit	2.5	Charge check valves (2 pcs)	5.3	Clogging indicator for pilot oil filter
MA, MB	Gauge port-system pressure	TP	Return line pressure limiter override	3.1	Low pressure relief valve	6	High pressure relief valve
MSt	Gauge port-charge pressure	1	Basic pump	3.2	Flushing flow shuttle valve	7	Interface for short cut valve
SSp	Suction port for charge pump	2.1	Charge pump	4	Proportional control valve	8	Pressure limiter override (main stage)
SSt	Suction port for pilot pump	2.2	Charge pressure relief valve	5	Pilot pump	8.1	Pressure limiter override (pilot stage)
pSt1	Outlet port pilot pump	2.3	Charge flow filter	5.1	Pilot pressure relief valve		

Pump Dimensions - TVXS - 066/090

ES Control

Dimensions in mm

Type ES, Electric Motor Displacement Control

Control displacement from +
 V_{max} to $-V_{max}$ through V_0

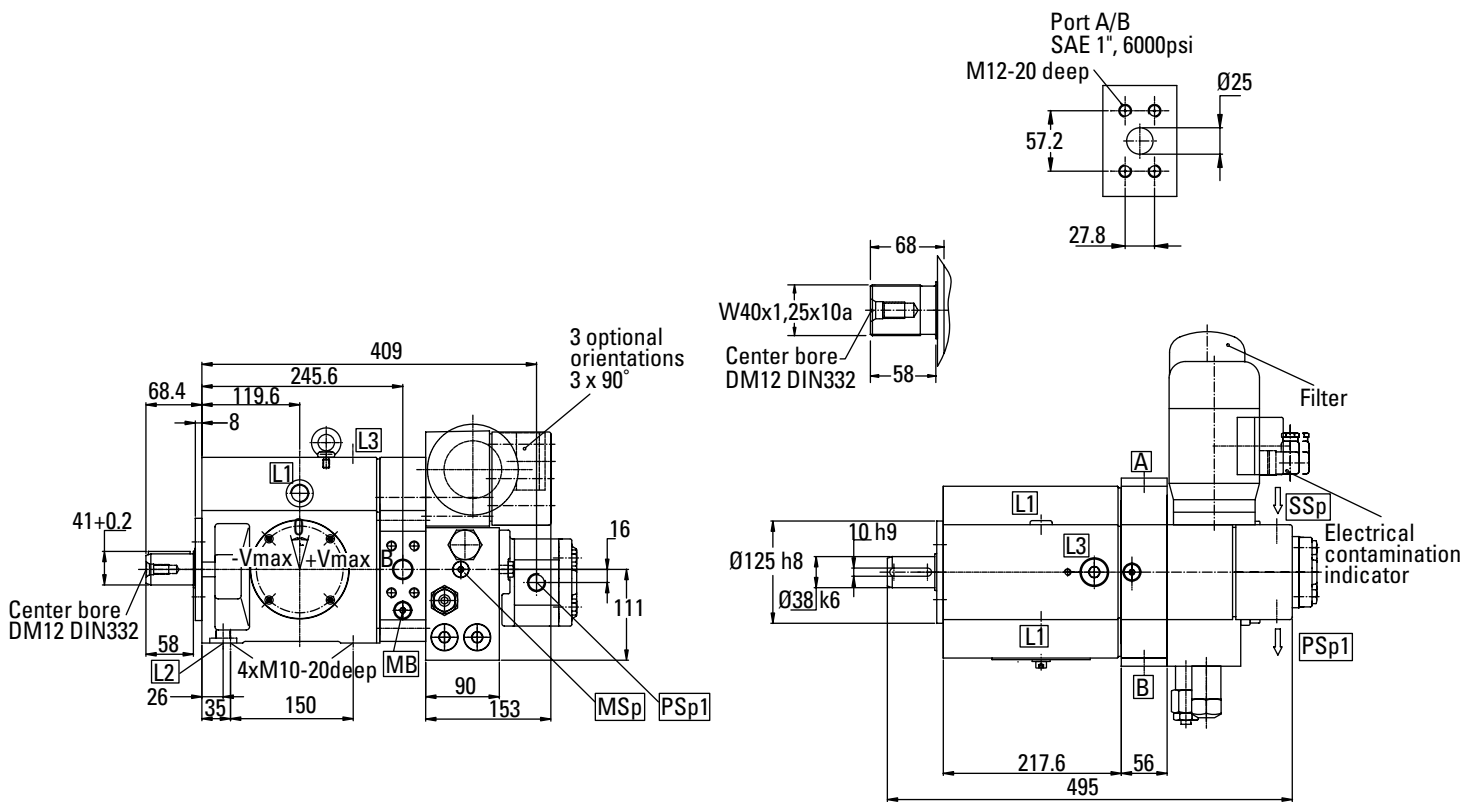

A, B	System pressure port (see detail)	L2	M18x1.5x12-deep supplementary drain, or bleed plug. Must be drained in addition to L1 if the pump is installed with the shaft input end pointing upwards.	(L3)	Oil filling 7/8-14UNF- SAEJ475 or bleed plug. Must be drained in addition to L1 if the pump is installed with the shaft input end pointing downwards.	(MSp)	Gauge port charge pump pressure G 1/4
(L1)	Drain port M22x1.5/two drain ports, one supplied plugged			(MA)	Gauge port system pressure G 1/4	pSp1	Pressure port of charge pump G 1/2
				(MB)	Gauge port system pressure G 1/4	pSp2	Pressure port M22x1.5
						SSp	Suction port of charge pump G 3/4
						(...)	Normally plugged

Pump Dimensions - TVXS - 066/090

ES Control

(cont.)

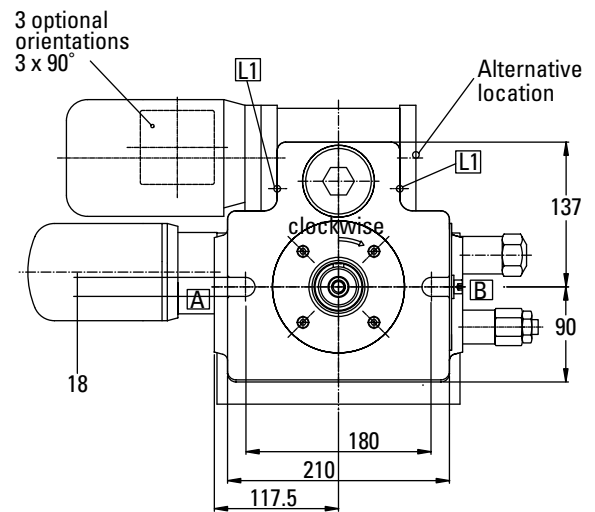
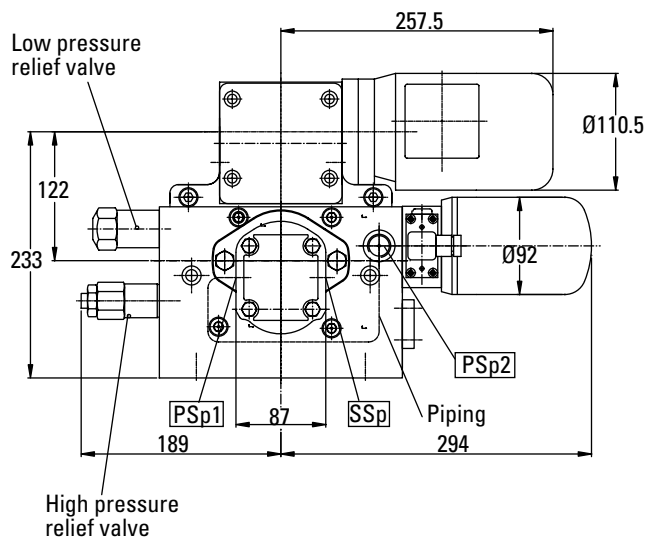

DIRECTION OF ROTATION	CONTROL	INPUT	OUTPUT
Right Hand Rotation	To + Vmax	B	A
	To - Vmax	A	B
Left Hand Rotation	To + Vmax	A	B
	To - Vmax	B	A

Pump Dimensions - TVXS - 066/090

HG Control

Dimensions in mm

Type HG, Handwheel Displacement Control

Control displacement from
+ Vmax to -Vmax through V0

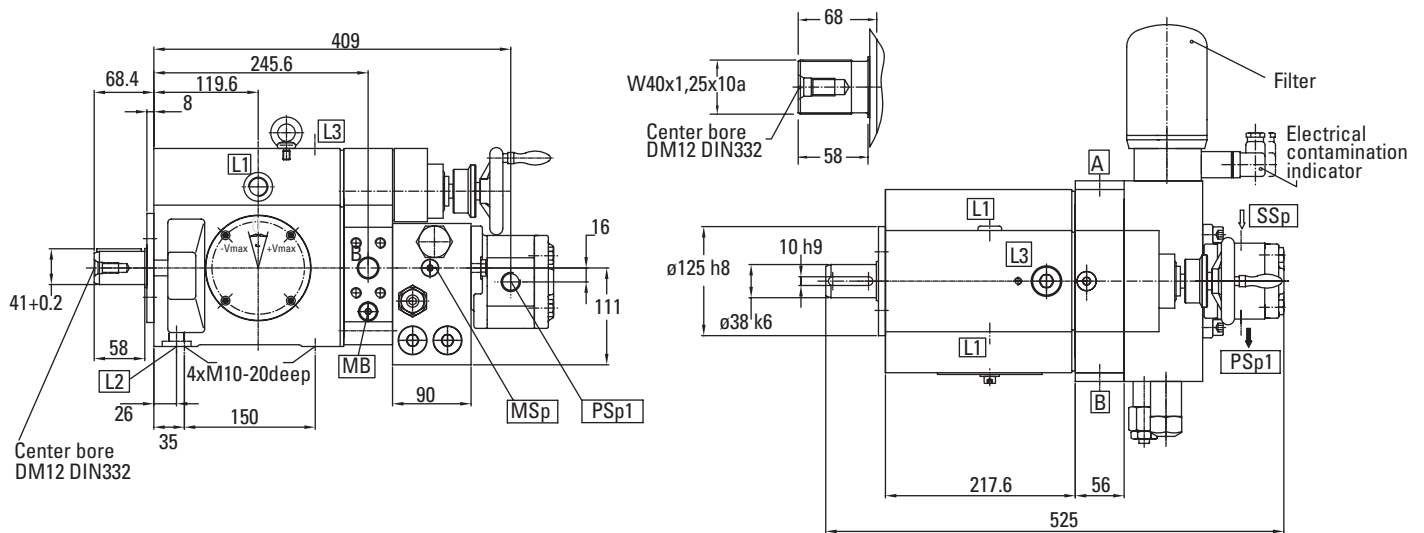

A, B	System pressure port (see detail)	L2	M18x1.5x12-deep supplementary drain, or bleed plug. Must be drained in addition to L1 if the pump is installed with the shaft input end pointing upwards.	(L3)	Oil filling 7/8-14UNF- SAEJ475 or bleed plug. Must be drained in addition to L1 if the pump is installed with the shaft input end pointing downwards.	(MSp)	Gauge port charge pump pressure G 1/4
(L1)	Drain port M22x1.5/two drain ports, one supplied plugged			(MA)	Gauge port system pressure G 1/4	pSp1	Pressure port of charge pump G 1/2
				(MB)	Gauge port system pressure G 1/4	pSp2	Pressure port M22x1.5
						SSp	Suction port of charge pump G 3/4
						(...)	Normally plugged

Pump Dimensions - TVXS - 066/090

HG Control

(cont.)

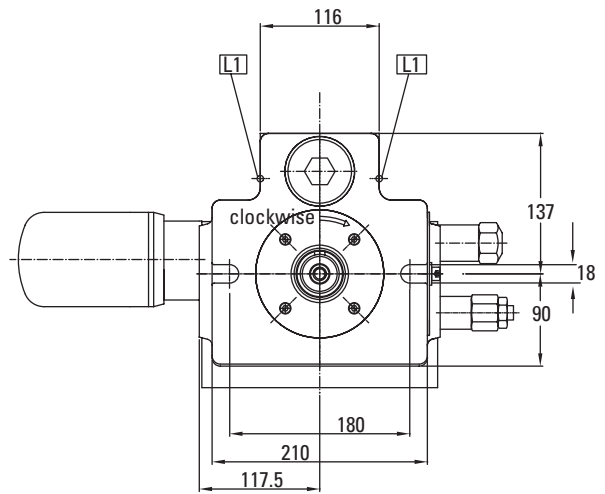
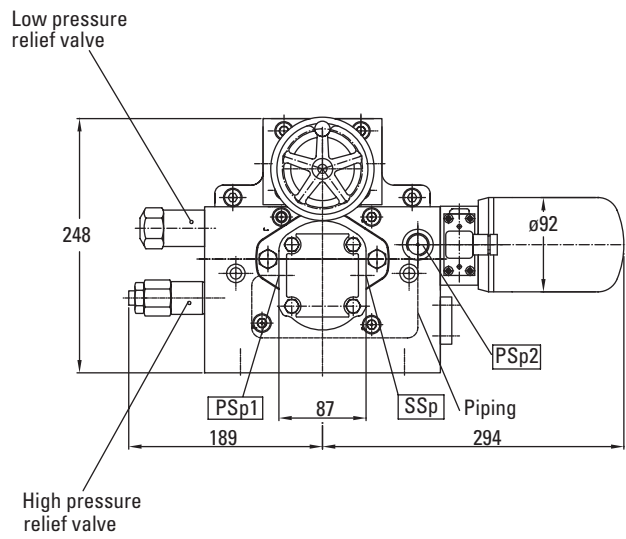

Port A/B
SAE 1", 6000psi

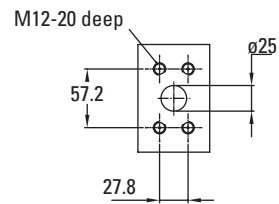

DIRECTION OF ROTATION	CONTROL	INPUT	OUTPUT
Right Hand Rotation	To + Vmax	B	A
	To - Vmax	A	B
Left Hand Rotation	To + Vmax	A	B
	To - Vmax	B	A

Pump Dimensions - TVXS - 066/090

FE Control

Dimensions in mm

Type FE, Screw Adjustment Displacement Control

Control displacement from
+ Vmax to - Vmax through V0

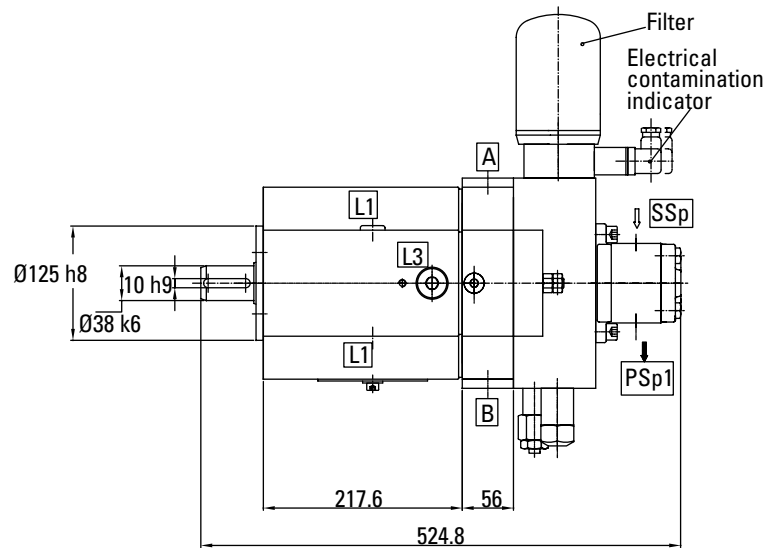
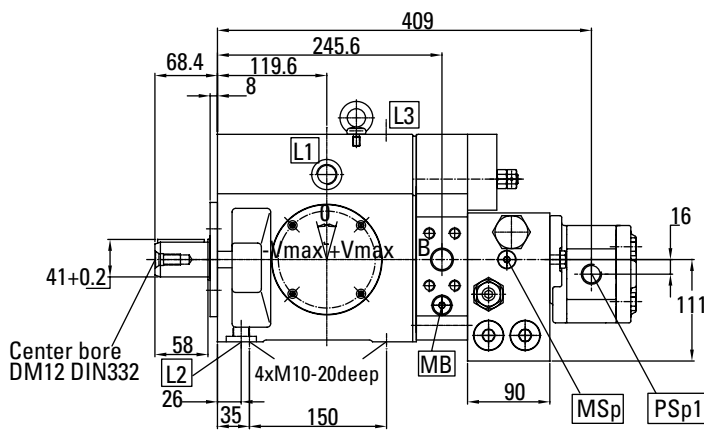

A, B	System pressure port (see detail)	(L3)	Oil filling 7/8-14UNF- SAEJ475 or bleed plug. Must be drained in addition to L1 if the pump is installed with the shaft input end pointing downwards.	(MSp)	Gauge port charge pump pressure G 1/4	(...)	Normally plugged
(L1)	Drain port M22x1.5/two drain ports, one supplied plugged	(MA)	Gauge port system pressure G 1/4	pSp1	Pressure port of charge pump G 1/2		
L2	M18x1.5x12-deep supplementary drain, or bleed plug. Must be drained in addition to L1 if the pump is installed with the shaft input end pointing upwards.	(MB)	Gauge port system pressure G 1/4	pSp2	Pressure port M22x1.5		
				SSp	Suction port of charge pump G 3/4		

Pump Dimensions - TVXS - 066/090

FE Control

(cont.)

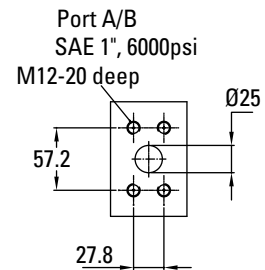
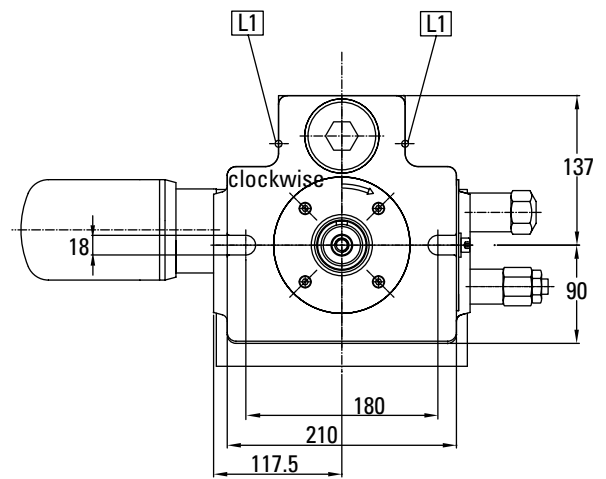
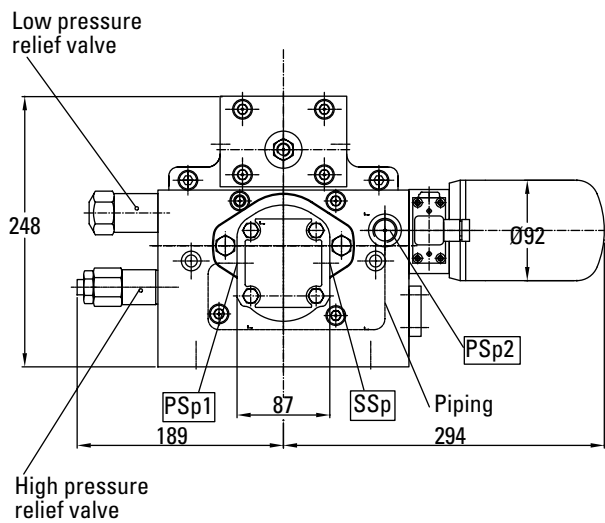
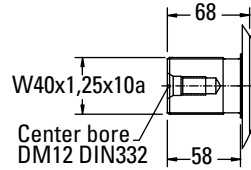

DIRECTION OF ROTATION	CONTROL	INPUT	OUTPUT
Right Hand Rotation	To + Vmax	B	A
	To - Vmax	A	B
Left Hand Rotation	To + Vmax	A	B
	To - Vmax	B	A

Pump Dimensions - TVXS - 066/090

DP Control

Dimensions in mm

Type DP, Pressure Signal Displacement Control

Control displacement from
+ Vmax to - Vmax through
V0, with internal mechanical
feedback

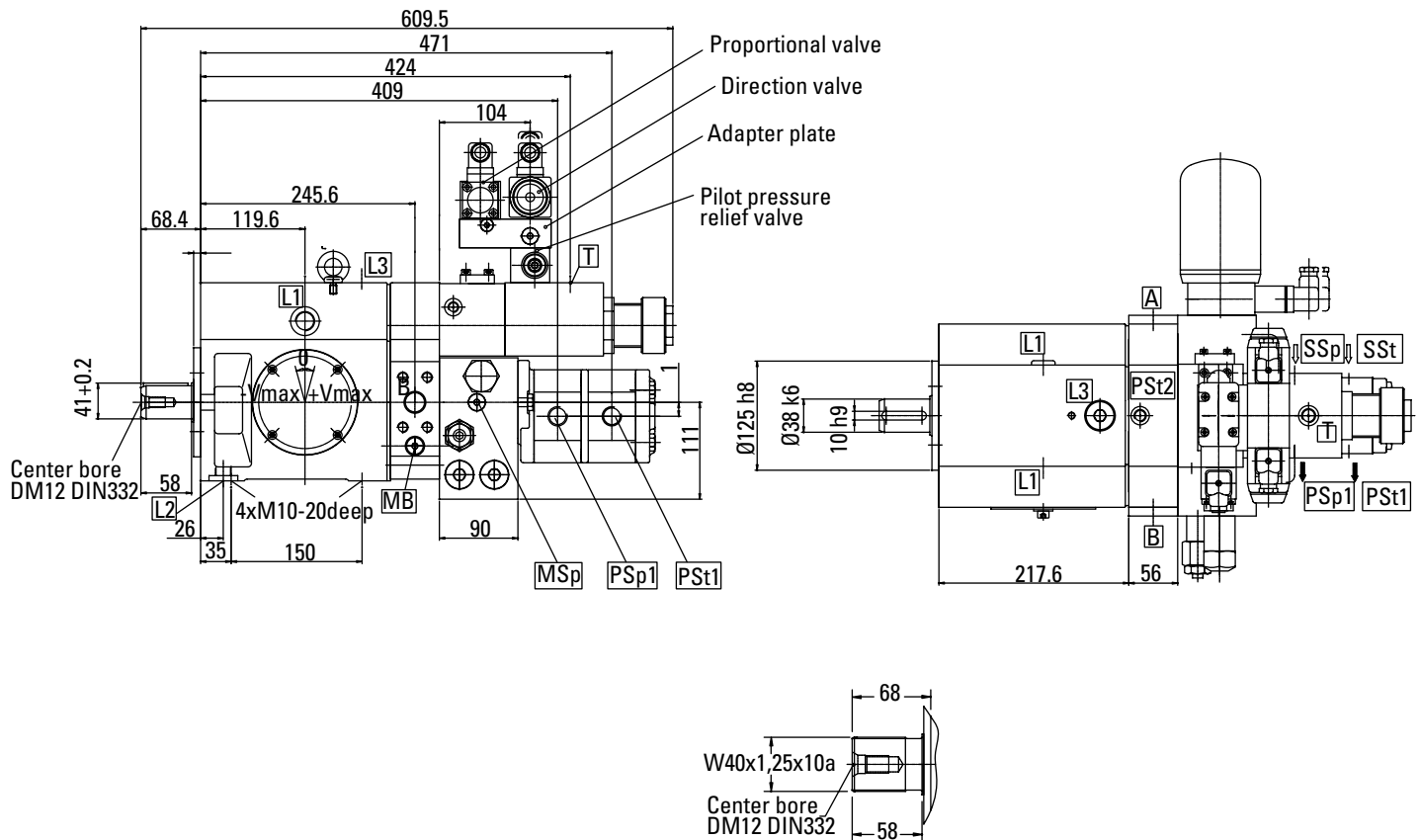

A, B	System pressure port (see detail)	(L3)	Oil filling 7/8-14UNF- SAEJ475 or bleed plug. Must be drained in addition to L1 if the pump is installed with the shaft input end pointing downwards.	(MB)	Gauge port system pressure G 1/4	SSp	Suction port of charge pump G 3/4
(L1)	Drain port M22x1.5/two drain ports, one supplied plugged			(MSp)	Gauge port charge pump pressure G 1/4	SSt	Suction port of pilot pump G 3/4
L2	M18x1.5x12-deep supplementary drain, or bleed plug. Must be drained in addition to L1 if the pump is installed with the shaft input end pointing upwards.	(MA)	Gauge port system pressure G 1/4	pSt1	Pilot pump outlet port G 1/2	T	Return line of control circuit G 1/2
				pSt2	Pilot pressure port M14x1.5	TEx	Return line Prop. valve G 1/2
				pSp1	Pressure port of charge pump G 1/2	(...)	Normally plugged
				pSp2	Pressure port M22x1.5		

Pump Dimensions - TVXS - 066/090

DP Control

(cont.)

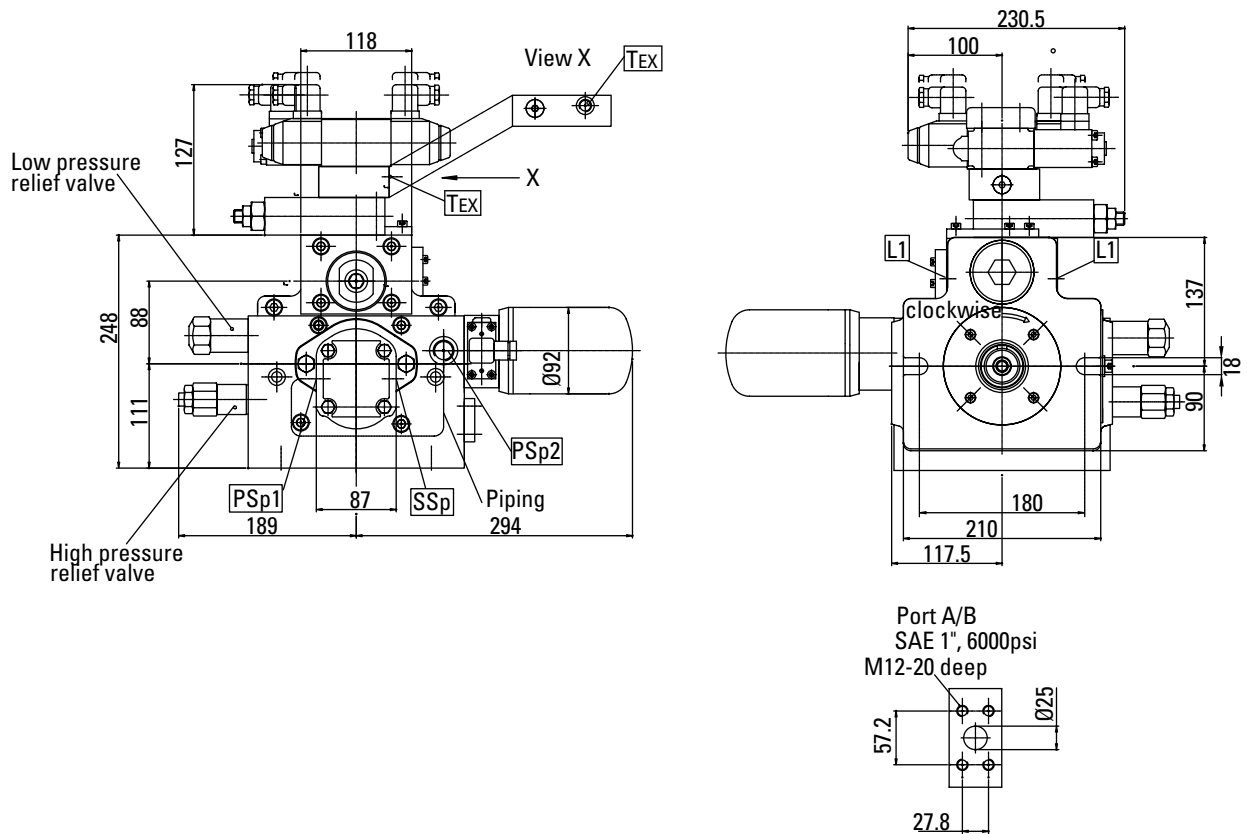

DIRECTION OF ROTATION	CONTROL	INPUT	OUTPUT
Right Hand Rotation	To + Vmax	B	A
	To - Vmax	A	B
Left Hand Rotation	To + Vmax	A	B
	To - Vmax	B	A

Pump Dimensions - TVXS - 066/090

SP Control

Dimensions in mm

Type SP, Proportional Valve Displacement Control

Control displacement from + Vmax to - Vmax V0, with position feedback (via potentiometer) of swashplate

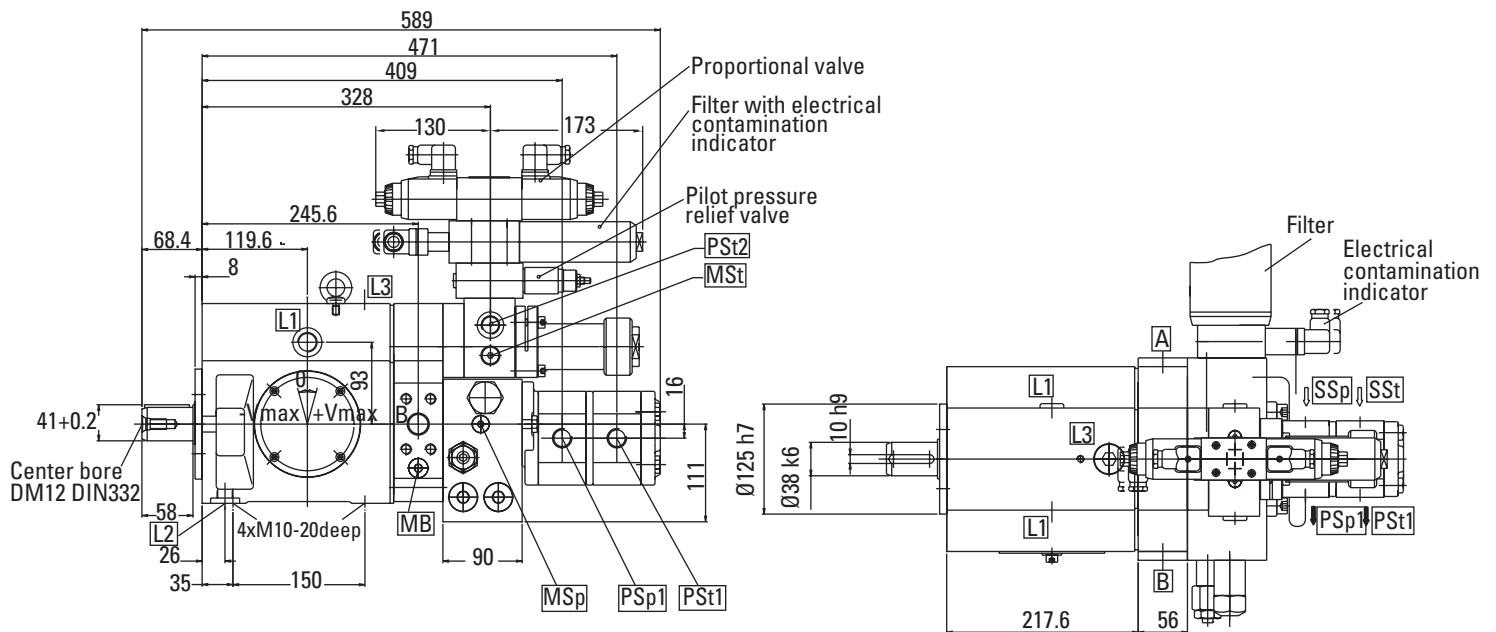

A, B	System pressure port (see detail)	(L3)	Oil filling 7/8-14UNF- SAEJ475 or bleed plug. Must be drained in addition to L1 if the pump is installed with the shaft input end pointing downwards.	(MSp)	Gauge port charge pump pressure G 1/4	SSp	Suction port of charge pump G 3/4
(L1)	Drain port M22x1.5/two drain ports, one supplied plugged	(MA)	Gauge port system pressure G 1/4	pSt1	Pilot pump outlet port G 1/2	SSt	Suction port of pilot pump G 3/4
L2	M18x1.5x12-deep supplementary drain, or bleed plug. Must be drained in addition to L1 if the pump is installed with the shaft input end pointing upwards.	(MB)	Gauge port system pressure G 1/4	pSt2	Pilot pressure port G 1/2	T	Return line of control circuit G 1/2
		(MSt)	Gauge port pilot pressure G 1/4	pSp1	Pressure port of charge pump G 1/2	(...)	Normally plugged
				pSp2	Pressure port M22x1.5		

Pump Dimensions - TVXS - 066/090

SP Control

(cont.)

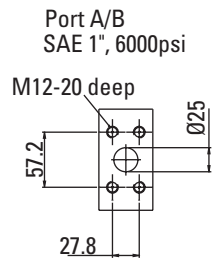
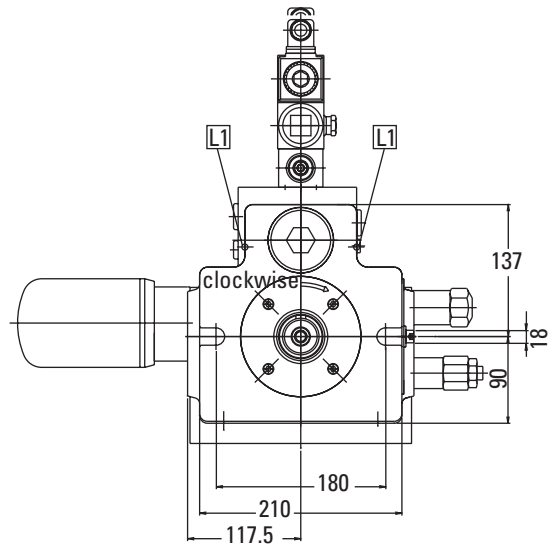
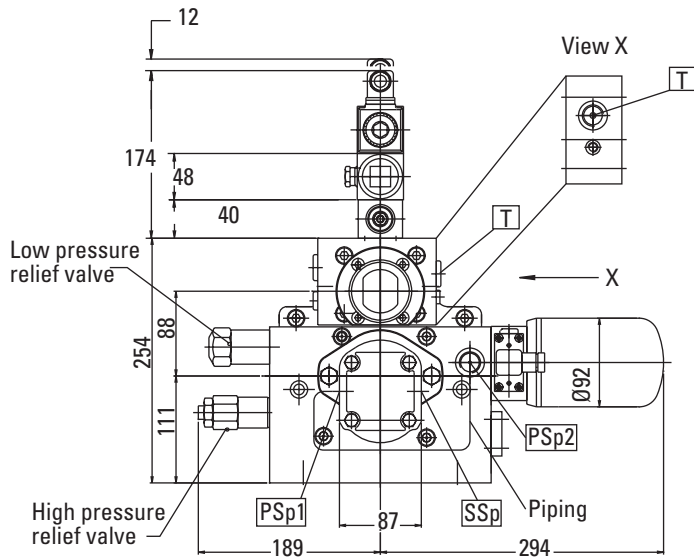
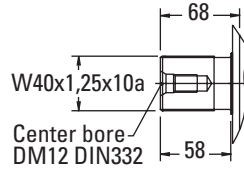

DIRECTION OF ROTATION	CONTROL	INPUT	OUTPUT
Right Hand Rotation	To + Vmax	B	A
	To - Vmax	A	B
Left Hand Rotation	To + Vmax	A	B
	To - Vmax	B	A

Pump Dimensions - TVXS - 130/180

ES Control

Dimensions in mm

Type ES, Electric Motor Displacement Control

Control displacement from
+ Vmax to - Vmax through V0

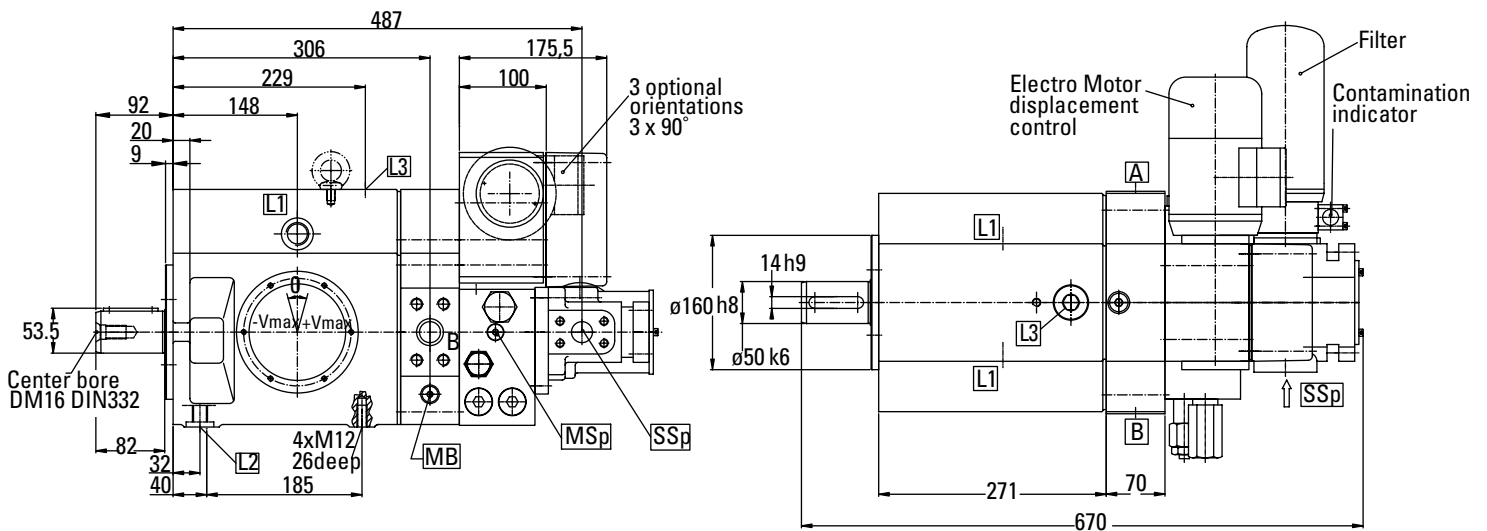

A, B	System pressure port (see detail)	L2	M18x1.5x12-deep supplementary drain, or bleed plug. Must be drained in addition to L1 if the pump is installed with the shaft input end pointing upwards.	(L3)	Oil filling 1-1/16-12UNF SAEJ475 or bleed plug. Must be drained in addition to L1 if the pump is installed with the shaft input end pointing downwards.	(MB)	Gauge port system pressure G 1/4
(L1)	Drain port M26x1.5/two drain ports, one supplied plugged			(MA)	Gauge port system pressure G 1/4	(MSp)	Gauge port charge pump pressure G 1/4
						SSp	Suction port of charge pump SAE 1"; 3000psi/500psi
						(...)	Normally plugged

Pump Dimensions - TVXS - 130/180

HG Control

Dimensions in mm

Type HG, Handwheel Displacement Control

Control displacement from
+ Vmax to - Vmax through V0

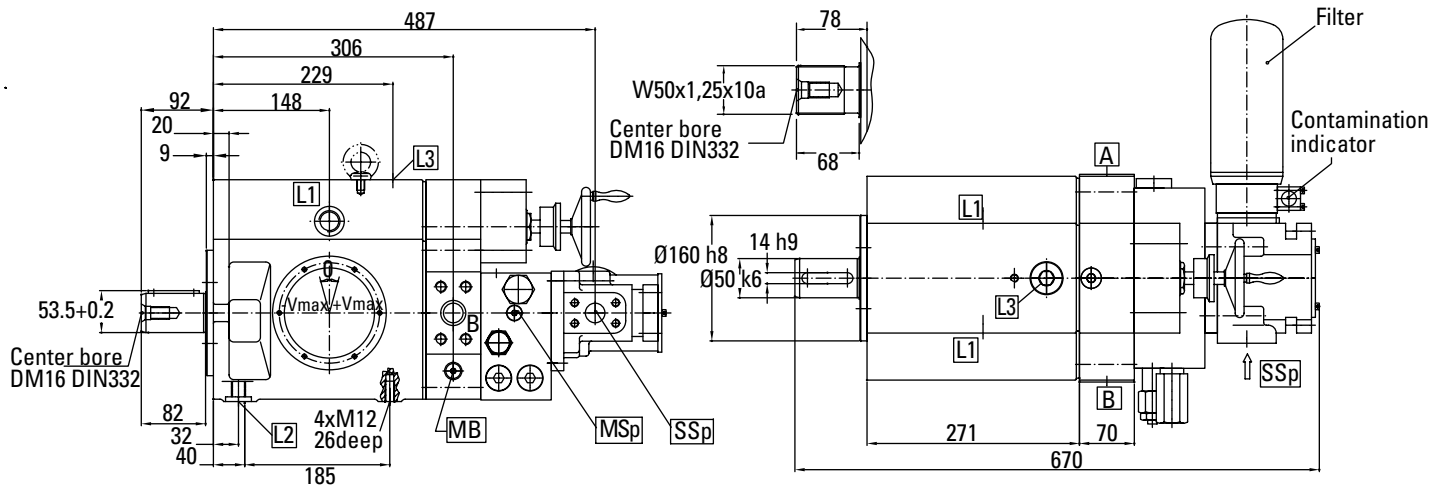

A, B	System pressure port (see detail)	L2	M18x1.5x12-deep supplementary drain, or bleed plug. Must be drained in addition to L1 if the pump is installed with the shaft input end pointing upwards.	(L3)	Oil filling 1-1/16-12UNF SAEJ475 or bleed plug. Must be drained in addition to L1 if the pump is installed with the shaft input end pointing downwards.	(MB)	Gauge port system pressure G 1/4
(L1)	Drain port M26x1.5/two drain ports, one supplied plugged			(MA)	Gauge port system pressure G 1/4	(MSp)	Gauge port charge pump pressure G 1/4
						SSp	Suction port of charge pump SAE 1"; 3000psi/500psi
						(...)	Normally plugged

Pump Dimensions - TVXS - 130/180

HG Control

(cont.)

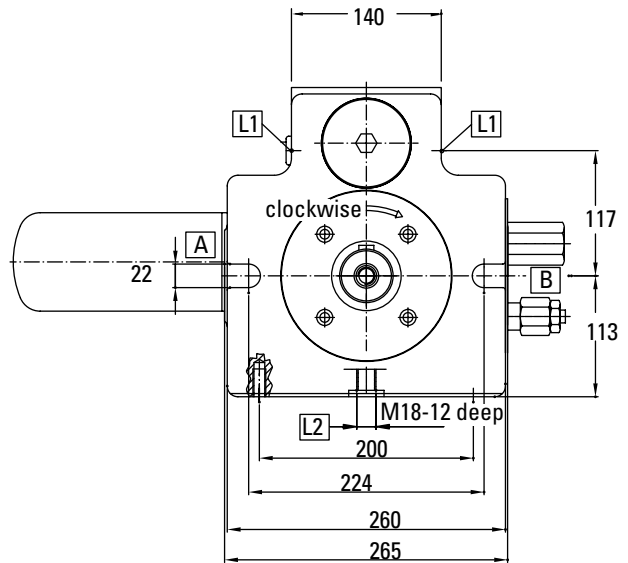
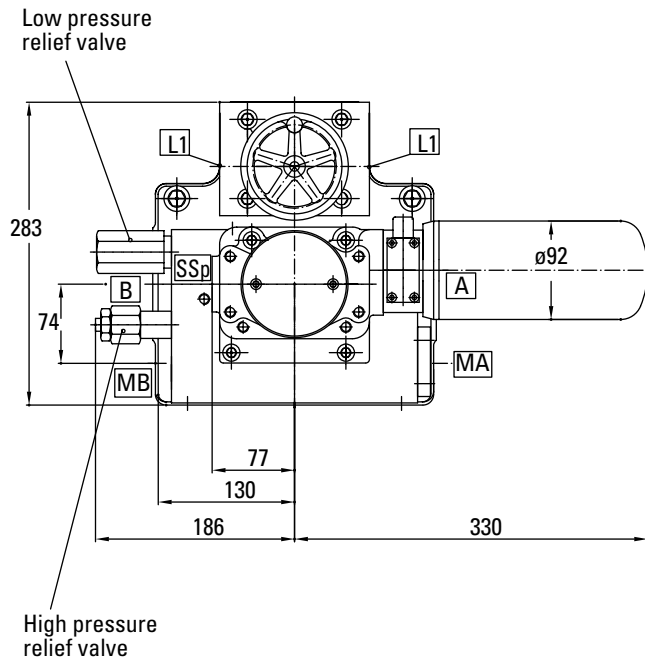

Port SSp
SAE 1", 3000psi/500psi

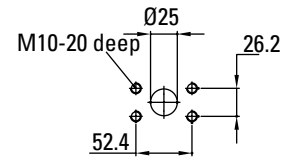

DIRECTION OF ROTATION	CONTROL	INPUT	OUTPUT
Right Hand Rotation	To + Vmax To - Vmax	B A	A B
Left Hand Rotation	To + Vmax To - Vmax	A B	B A

Port A/B, SIZE 180
SAE 1 1/4", 6000psi

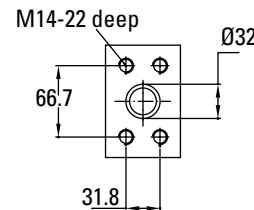

Port A/B, SIZE 130
SAE 1", 6000psi

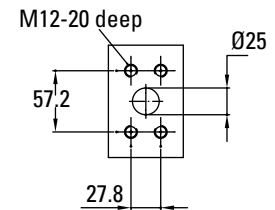

Pump Dimensions - TVXS - 130/180

FE Control

Dimensions in mm

Type FE, Screw Adjustment Displacement Control

Control displacement from
+ Vmax to - Vmax through V0

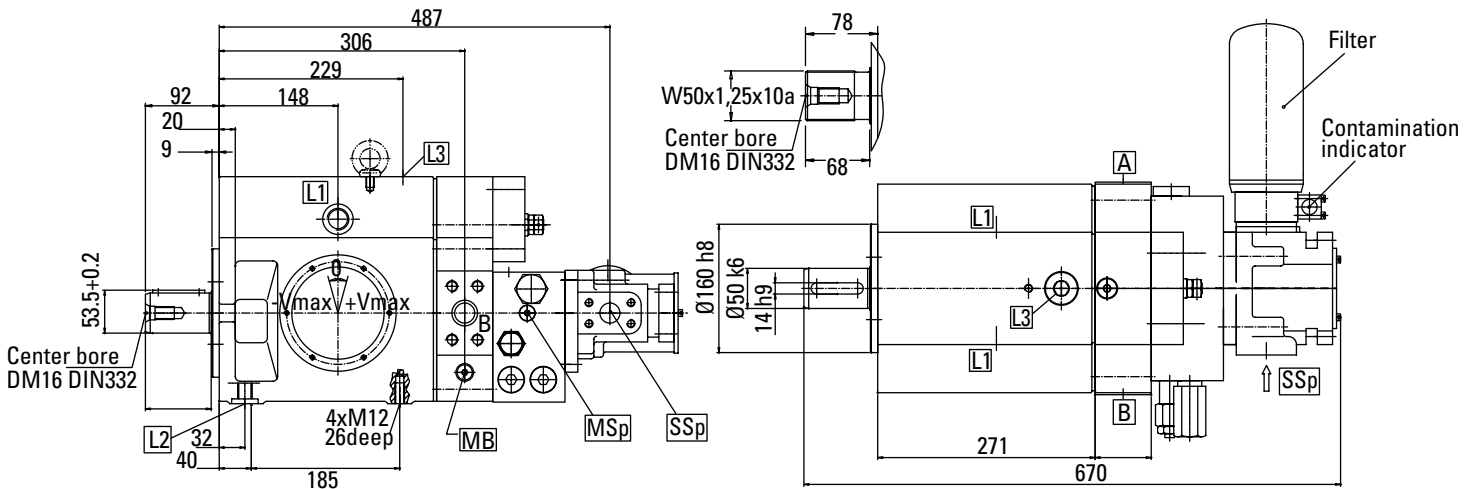

A, B	System pressure port (see detail)	L2	M18x1.5x12-deep supplementary drain, or bleed plug. Must be drained in addition to L1 if the pump is installed with the shaft input end pointing upwards.	(L3)	Oil filling 1-1/16-12UNF SAEJ475 or bleed plug. Must be drained in addition to L1 if the pump is installed with the shaft input end pointing downwards.	(MB)	Gauge port system pressure G 1/4
(L1)	Drain port M26x1.5/two drain ports, one supplied plugged			(MA)	Gauge port system pressure G 1/4	(MSp)	Gauge port charge pump pressure G 1/4
						SSp	Suction port of charge pump SAE 1"; 3000psi/500psi
						(...)	Normally plugged

Pump Dimensions - TVXS - 130/180

FE Control

(cont.)

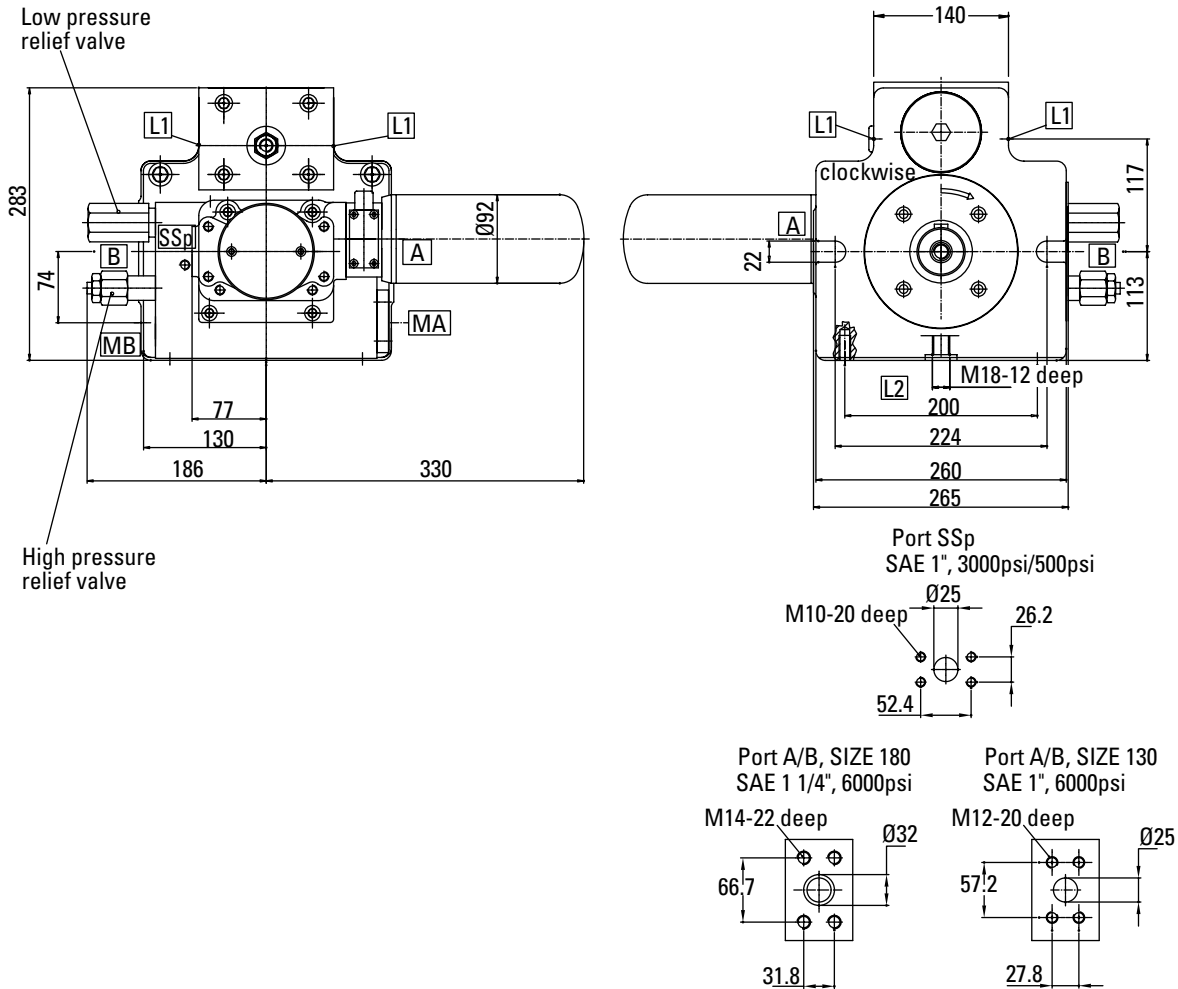

DIRECTION OF ROTATION	CONTROL	INPUT	OUTPUT
Right Hand Rotation	To + Vmax	B	A
	To - Vmax	A	B
Left Hand Rotation	To + Vmax	A	B
	To - Vmax	B	A

Pump Dimensions - TVXS - 130/180

DP Control

Dimensions in mm

Type DP, Pressure Signal Displacement Control

Control displacement from +Vmax to -Vmax through V0, with internal mechanical feedback

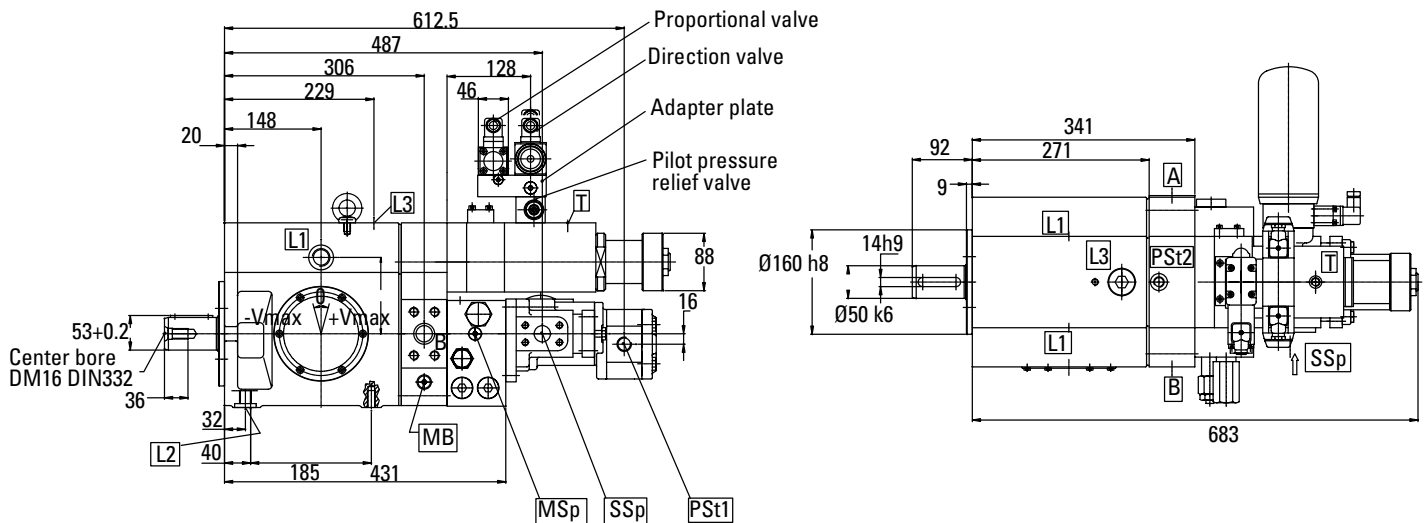

A, B	System pressure port (see detail)	(L3)	Oil filling 1-1/16-12UNF SAEJ475 or bleed plug. Must be drained in addition to L1 if the pump is installed with the shaft input end pointing downwards.	(MB)	Gauge port system pressure G 1/4	SSt	Suction port of pilot pump G 3/4
(L1)	Drain port M26x1.5/two drain ports, one supplied plugged			(MSp)	Gauge port charge pump pressure G 1/4	T	Return line of control circuit G 1/2
L2	M18x1.5x12-deep supplementary drain, or bleed plug. Must be drained in addition to L1 if the pump is installed with the shaft input end pointing upwards.	(MA)	Gauge port system pressure G 1/4	pSt1	Pilot pump outlet port G 1/2	Tex	Return line Prop. valve G 1/4
				pSt2	Pilot pressure port M16x1.5	(...)	Normally plugged
				SSp	Suction port of charge pump SAE 1", 3000psi/500psi		

Pump Dimensions - TVXS - 130/180

DP Control

(cont.)

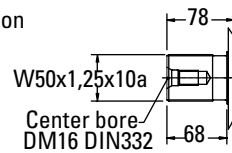
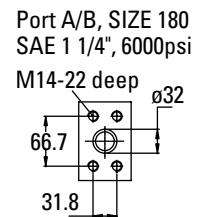
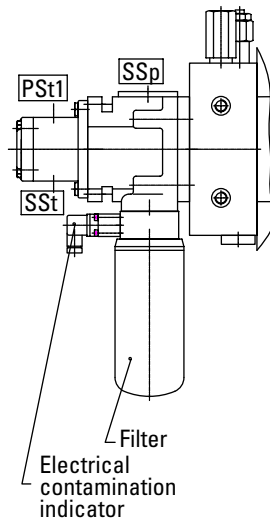
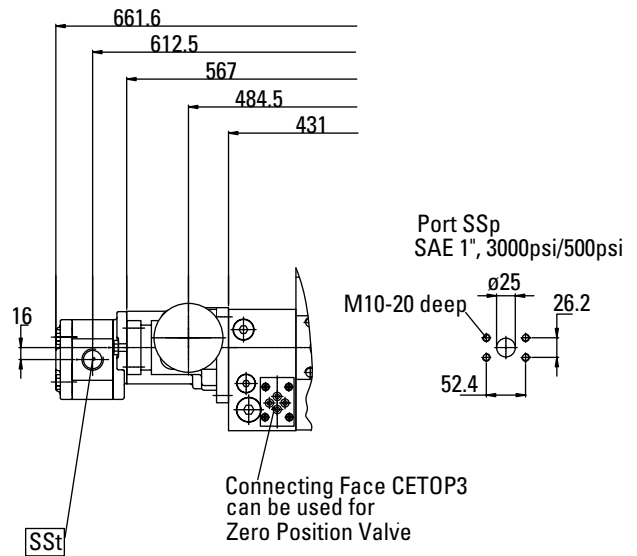
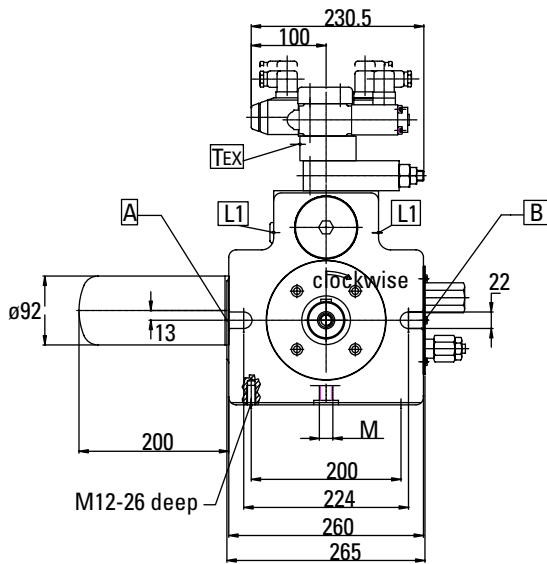
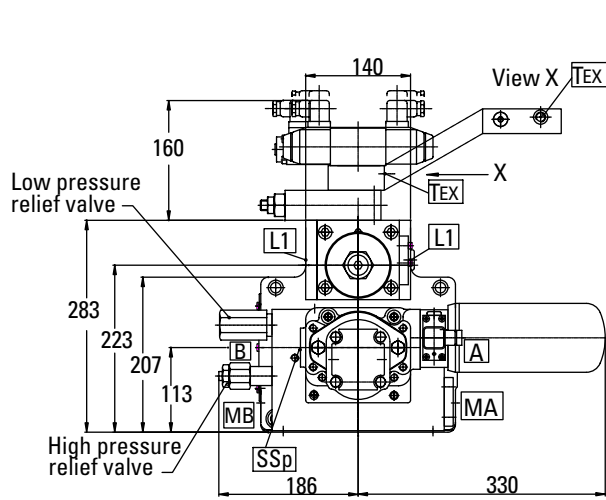

DIRECTION OF ROTATION	CONTROL	INPUT	OUTPUT
Right Hand Rotation	To + Vmax	B	A
	To - Vmax	A	B
Left Hand Rotation	To + Vmax	A	B
	To - Vmax	B	A

Pump Dimensions - TVXS - 130/180

SP Control

(cont.)

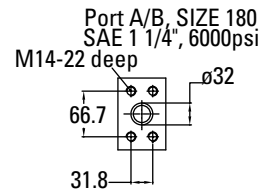
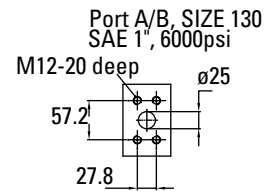
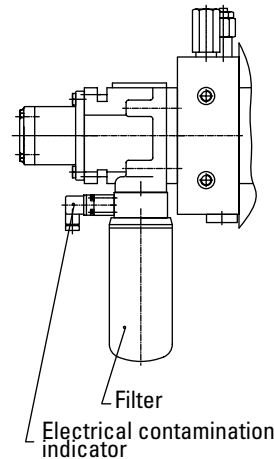
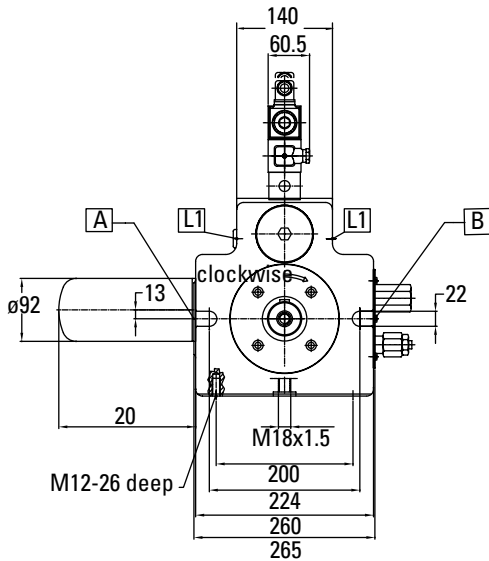
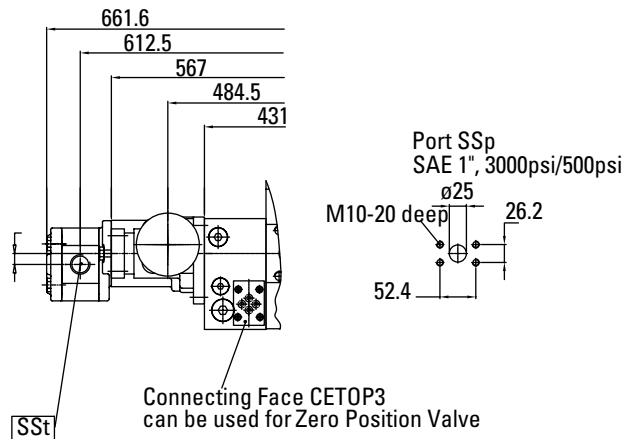
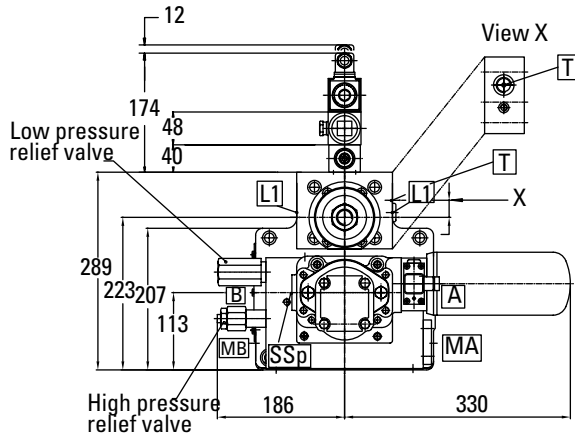

DIRECTION OF ROTATION	CONTROL	INPUT	OUTPUT
Right Hand Rotation	To + Vmax	B	A
	To - Vmax	A	B
Left Hand Rotation	To + Vmax	A	B
	To - Vmax	B	A

SAE 4-Bolt Mounting Pads

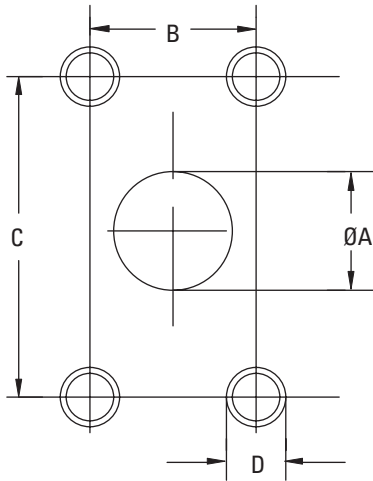

SIZE	DIM.	CODE 62 SERIES	
		1"	1 1/4"
	A	25	32 max
	B	27,8	31,8
	C	57,2	66,7
	D	M12 x 18	M14 x 24
TVX 066	Inlet	•	
	Outlet	•	
TVX 090	Inlet	•	
	Outlet	•	
TVX 130	Inlet	•	
	Outlet	•	
TVX 180	Inlet		•
	Outlet		•

Thru-drive Shaft Output Torque

MAXIMUM OUTPUT TORQUE, NM (LB.FT)

Pump Size	Keyed Shaft Increasing Load	Keyed Shaft Increasing Load	Splined Shaft
066	520 (383)	260 (190)	660 (485)
090	520 (383)	260 (190)	660 (485)
130	720 (530)	360 (265)	900 (665)
180	720 (530)	360 (265)	900 (665)

INSTALLATION POSITION DRAIN PIPING

Shaft pointed upwards

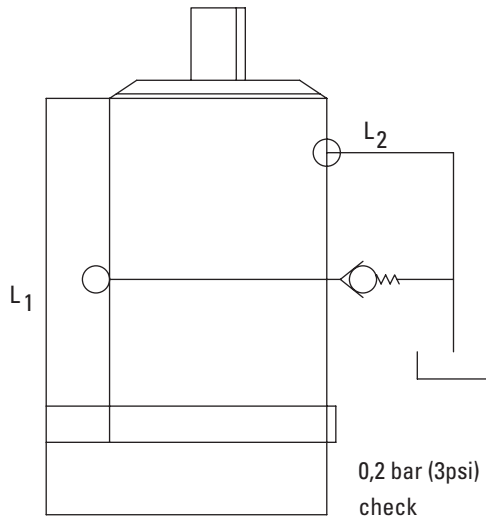

Shaft pointed downwards

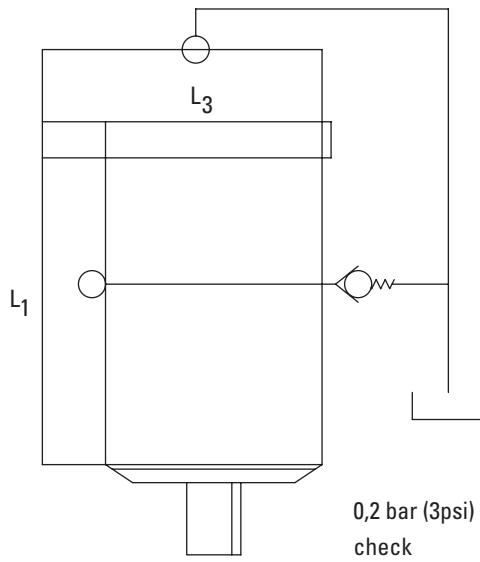

Application Data - Fluid Recommendations

Case Flushing Requirements

A check valve must not be used in the drain pipe. The drain pipe must interminate below the oil level in the reservoir.

For all other conditions with low pressure <20 bar (<300psi) and low flow (<10% of Qmax) case flushing is required.

For operation with special fluids HFB and HFC, case flushing is recommended.

Flushing Flow

Flushing flow via the pump case should be >1% of maximum pump flow. Maximum flushing flow depends on case pressure.

Notes:

- All listed ratings are based on the use of a good quality fluid.
- Alternative fluids have a reduced tolerance for contamination over petroleum-base fluids. Good filtration is therefore critical.
- The pumps will provide exceptional life when used with a good quality clean fluid at the pump ratings specified for that fluid.

Fluids

Pumps in the catalog are primarily designed to operate with conventional petroleum-based hydraulic oil. Alternative fluids and restrictions:

- Fluid maintenance is critical to the durability of all hydraulic components, and particularly so with hydraulic pumps. This becomes even more of a factor when alternative fluids are used. All types of alternative fluids require extensive maintenance in order to maintain proper levels of water content, acidity, viscosity and contamination.

Fluid Cleanliness

These pumps are rated for anti-wear petroleum fluids with a contamination level of 18/15/13 per ISO 4406. Operation in fluids with higher contamination levels than this is not recommended and may reduce the life of the pump components. Fluids other than petroleum, severe

service cycles, or temperature extremes are cause for adjustment of these codes. Please contact your Eaton representative for special duty cycle recommendations.

Eaton pumps, as well as any variable displacement piston pumps, will operate with apparent satisfaction in fluids up to the rating specified here.

Experience has shown, however, that pump and hydraulic system life is not optimized with high fluid contamination levels (high ISO cleanliness codes).

Proper fluid condition is essential for long and satisfactory life of hydraulic components and systems. Hydraulic fluid must have the correct balance of cleanliness, materials, and additives for protection against wear of inclusion of air.

Essential information on the correct methods for treating hydraulic fluid is included in Eaton publication 561- "Vickers Guide to Systemic Contamination Control"-

available from your local Eaton distributor.

In this publication, filtration and cleanliness levels for extending the life of axial piston pumps and other system components are listed. Included is an excellent discussion of the selection of products needed to control fluid condition.

Ordering Procedure

When ordering please specify full model designation of items required; see "Model Codes" section of this catalog.

Note the following:

- Designation of variable displacement pumps must include the supplementary designation of the required control.

FLUIDS

TYPE	CLASSIFICATION	MAX PRESSURE BAR	MAX SPEED RPM	RECOMMENDED SEAL MATERIAL	MAX OPERATING TEMPERATURE °C	BEARING LIFE
Oil in Water Emulsion	HFAE	Not Rated				0%
Water in oil Emulsion	HFB	250	1800	Fluorocarbon	49	50%
Water Glycol	HFC	250	1800	Fluorocarbon	49	25%
Phosphate Ester	HFDR	350/420	1800	Fluorocarbon	66	100%
Polyol Ester	HFDU	350/420	1800	Fluorocarbon	66	100%

Description of Closed Loop Transmission with Electric Motor Displacement Control

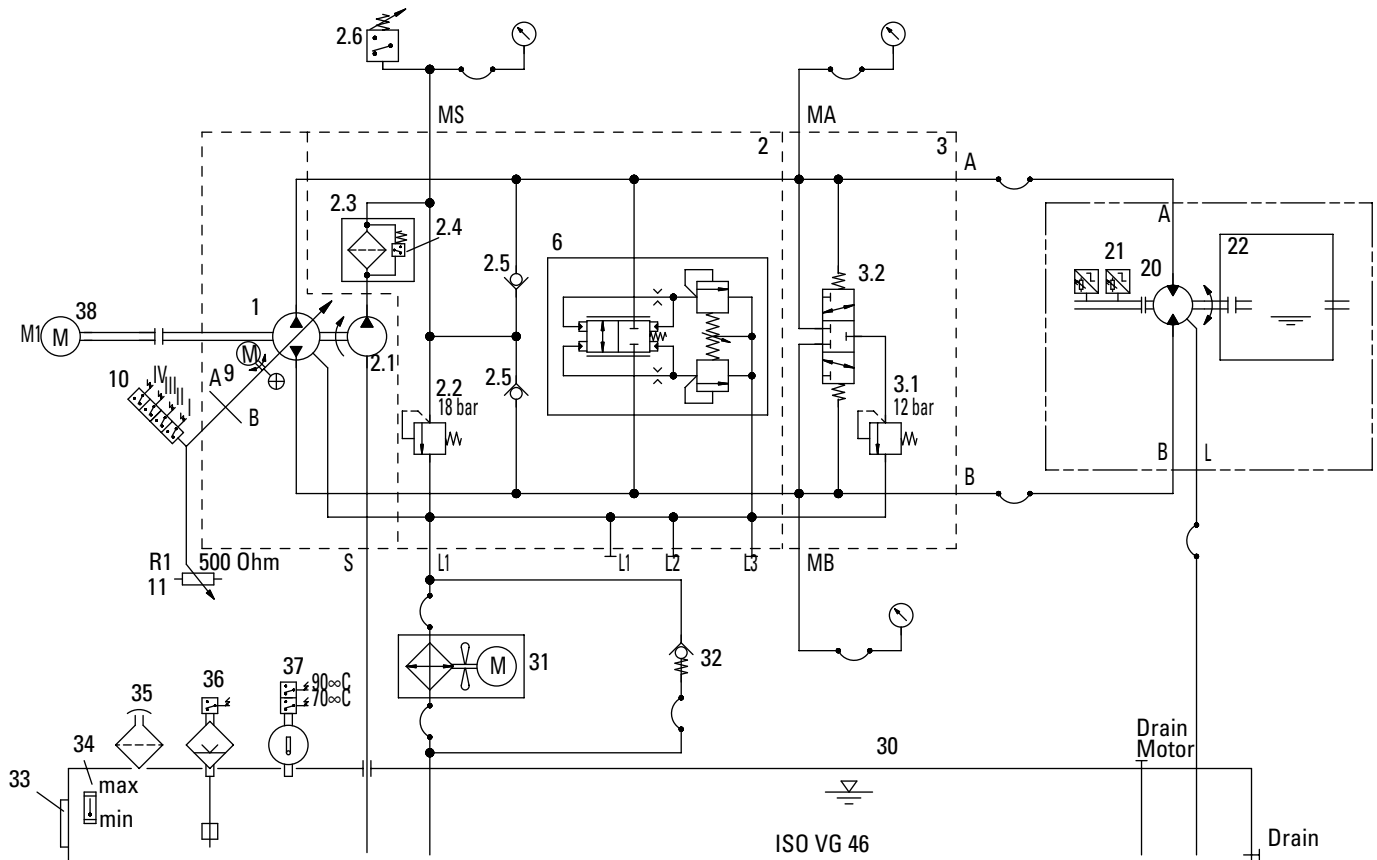

The schematic enclosed shows a typical heavy duty hydrostatic transmission. The pump and motor are the main components. The filter, reservoir, heat exchanger and oil lines make up the rest of the system.

The function of these components is described below:

The Pump

The pump generates the flow of high pressure oil. The typical transmission employs a variable displacement pump. The variable displacement feature allows

the amount of oil pumped to be varied. And the amount of oil pumped controls the motor's output speed. For example, when the pump's displacement is zero, no oil is pumped and the transmission's output shaft is at rest. Conversely, maximum displacement produces maximum speed. The direction of high pressure flow can also be reversed; doing so reverses the direction the output shaft rotates. An external energy source, called the prime mover (usually an electrical motor), turns the input shaft of the pump.

The Motor

The motor uses the high pressure oil flow from the pump to produce transmission output. The high pressure oil comes to the motor through one of the high pressure lines. It enters the motor, turns the output shaft, then returns to the pump. The pump and motor in the drawing are connected in a closed-loop circuit.

Important:

Remember, the pump generates flow, and the load on the motor's output shaft causes resistance to that flow. That resistance to flow is what creates the high pressure. Therefore, the oil flowing in the lines that connect the pump and motor is called "high pressure flow."

The pump and motor in the drawing are contained in separate housings. This configuration provides maximum flexibility in design and transmission installation.

Application Information

(cont.)

The Charge Pump

The charge pump generates a low pressure oil flow that has three functions. First, it supplies a continuous flow of oil through the pump and motor cases. This "case flow" keeps the transmission cool. In the drawing, the case flow goes from the motor to the pump, then to the heat exchanger and back to the reservoir. Second, the charge pump keeps the high pressure lines filled. This ensures that the transmission remains primed even after extended periods of running in neutral. Finally, charge pump flow provides back pressure in the high pressure lines when the transmission is in forward or reverse. The charge pump contains a relief valve that helps maintain the pressure of the low pressure oil flow.

The charge pump bolts onto the pump and its input shaft connects with the input shaft of the pump. The charge pump inlet receives oil from the reservoir.

The Valve Block

The valve block contains a two-sided high pressure relief valves, a shuttle valve and a charge pressure relief valve.

The high pressure relief valve protects the transmission from pressures that are too high. The shuttle valve and charge pressure relief valve direct excess charge pump flow into the pumps case. This case flow cools the pump. The valve block bolts directly to the pump.

The Heat Exchanger, Reservoir, Filter, and Oil Lines

The heat exchanger, reservoir, filter and oil lines are all necessary for heavy duty transmission operation. The heat exchanger connects between the case flow outlet and the reservoir. It cools the oil before it enters the reservoir. The heat exchanger must be fitted with a by-pass valve that opens when case drain pressure gets too high. The by-pass valve is especially important during cold starts when the oil is thick. The reservoir supplies a steady flow of oil to the charge pump inlet. It also provides room for the oil to expand as it gets hot and for entrapped air to escape. The filter is installed between the charge pump outlet and the valve block. It removes contaminants from the oil.

The oil lines provide passage ways for the oil flowing among the transmission components. They must be strong enough to withstand the pressures generated and may be rigid or flexible.

Description of Operation

A hydrostatic transmission is a dynamic system that operates through a wide range of conditions. Nevertheless, this wide operating range can conveniently be divided into three basic modes: neutral, forward and reverse.

The schematics and their accompanying explanations will help you visualize what's going on inside the transmission during each of the operating modes.

Important: As you study the following flow descriptions, remember that in all modes of operation, the input shaft of the pump is being turned by an external power source.

Neutral

The hydrostatic transmission is in neutral when the variable pump's displacement is zero. With zero displacement, no high pressure oil is pumped to the motor and its output shaft is stopped.

Putting the control signal in the neutral position centers the swashplate. With the swashplate centered the pistons don't reciprocate as the cylinder barrel is rotated and no high pressure oil is pumped.

The charge pump, which is connected to the input shaft, pumps oil in all modes of transmission operation. In neutral, it takes cooled, filtered oil from the reservoir and fills the system. Charge pump flow passes through the check valves in the pump's end cover and fills the pump pistons, the high pressure lines and the motor's pistons. This oil flow is intended to make up for internal leakage and keep the circuit primed.

After the high pressure circuit has been primed, the charge pump pressure opens the charge pressure relief valve located in the charge pump. This directs the charge pump flow through the pump case and back to the reservoir. This oil flow flushes and cools the pump.

The forward mode and the reverse mode are similar, so they will be grouped and called the forward! reverse mode.

Application Information

(cont.)

Forward/Reverse

The hydrostatic transmission is in the forward/reverse mode when flow in the high pressure circuit causes the motor shaft to rotate.

Flow in the high pressure circuit is created by tilting the pump's variable swashplate from its center or neutral, position. With the swashplate tilted, the pistons reciprocate as the cylinder barrel rotates and flow is generated.

The swashplate may be tilted to either side of center. Tilting it one way generates flow that makes the transmission go forward. And tilting it the other way reverses flow and the motor shaft rotates in the opposite direction.

Besides controlling direction, the swashplate angle also controls output speed. Swashplate angle affects speed by changing the pump's displacement. The

largest swashplate angle produces the largest displacement and the fastest motor speed.

The Electrical Motor Displacement Control circuit varies the swashplate angle by turning a spindle directly fixed to the servo piston. According to the direction of rotation of the control motor, the spindle turns and the swashplate is tilt until the motor is switched off (for more detailed explanations refer to separate description of the Electrical Motor Displacement Control).

Charge pump flow that is not used by the control circuit passes through the end cover check valve into the bw pressure side of the loop. There it provides back pressure to the motor pistons.

The spring centered shuttle valve, located in the pump's valve block, moves to connect the low pressure side of the loop to the charge pressure

relief valve. When back pressure gets high enough the charge pressure relief valve, in the valve block, opens and charge pump flow enters the the pump case.

Case flow flushes the pump cases and helps keep the transmission cool. The charge pressure relief valve typically has a lower setting than the charge pressure relief valve in the charge pump. This is so case flow will begin at the motor, go to the pump, and return to the reservoir.

The charge pressure relief valve in the charge pump opens when the transmission is in neutral and the shuttle valve is centered.

The 2-side high pressure relief valve opens to connect the high pressure side of the loop to the low pressure side if the motor stalls and the pressure gets too high. This valve works in forward and in reverse direction.

Last remark

All valves, relief valves and switches, are adjusted at the test bench according customers specification and needs and must not be misplaced without special knowlegde of the hydraulic system!

Eaton
14615 Lone Oak Road
Eden Prairie, MN 55344
USA
Tel: 952 937-9800
Fax: 952 974-7722
www.hydraulics.eaton.com

Eaton
20 Rosamond Road
Footscray
Victoria 3011
Australia
Tel: (61) 3 9319 8222
Fax: (61) 3 9318 5714

Eaton
Dr.-Reckeweg-Str.1
D-76532 Baden-Baden
Germany
Tel: +49 (07221) 682-0
Fax: +49 (07221) 682-788

VICKERS[®]

EATON

Vickers

© 2003 Eaton Corporation
All rights reserved
Printed in USA
Document No. V-PUPI-MC001-E
March 2003