

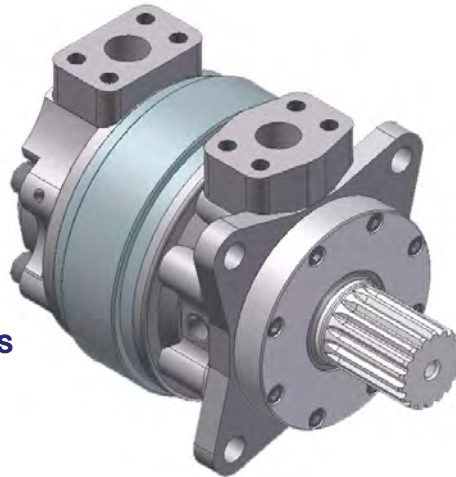

# 37 - 57 Series

## CODE 62 HIGH PERFORMANCE MOTOR

- Tapered Roller Bearings with Increased Radial and Axial Capacity
- Larger Diameter Output Shafts



### Features:

- Code 62 Ports - 4500 PSI Continuous  
5000 PSI Intermittent
- Higher Speeds up to 1100 RPM
- Up to 300 Horsepower Output

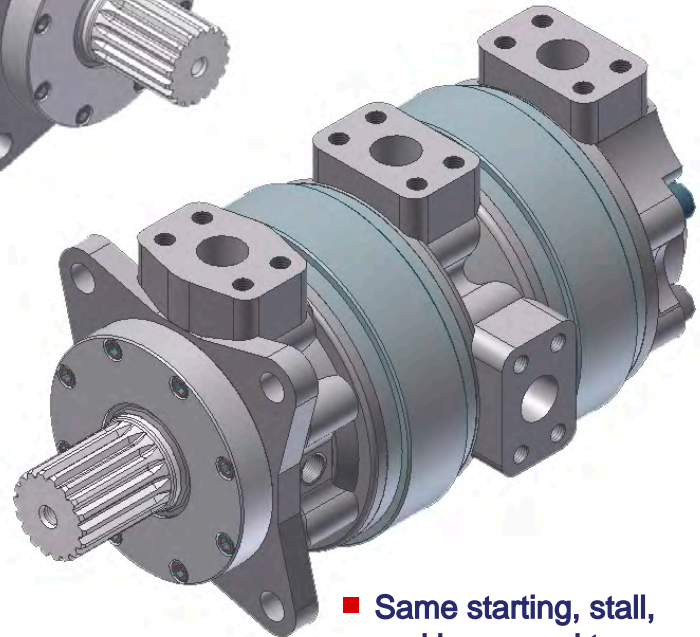
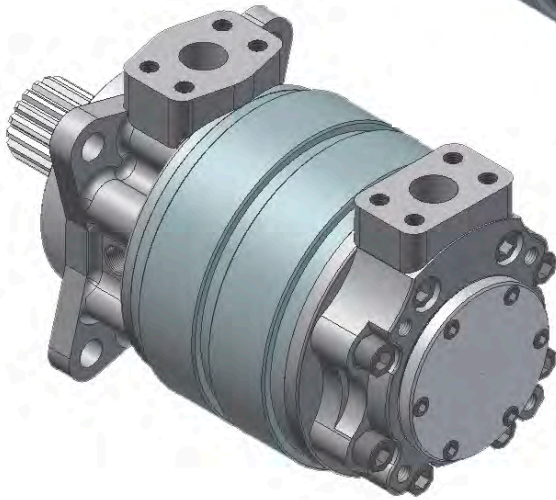

- Single stack - 37/57 series 112/127 lbs.
- Double stack - 37/57 series 149/179 lbs.
- 4-port - 37/57 series 187/216 lbs.

- Same starting, stall, and low speed torque
- 2-speed operation on 4-port with some external valving

### CROSS SECTION

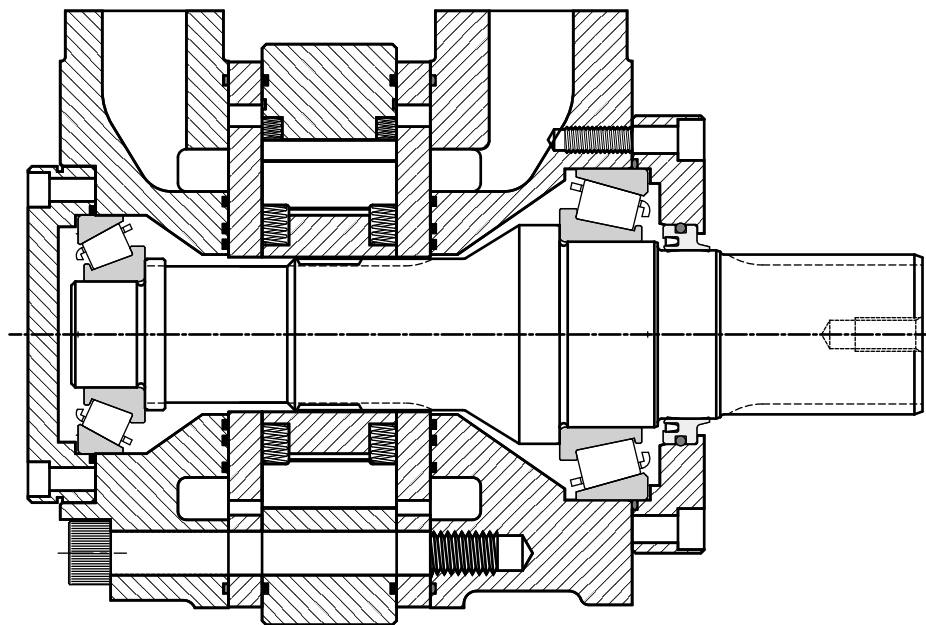

## Envelope Drawing - High Performance Motor - All Displacements

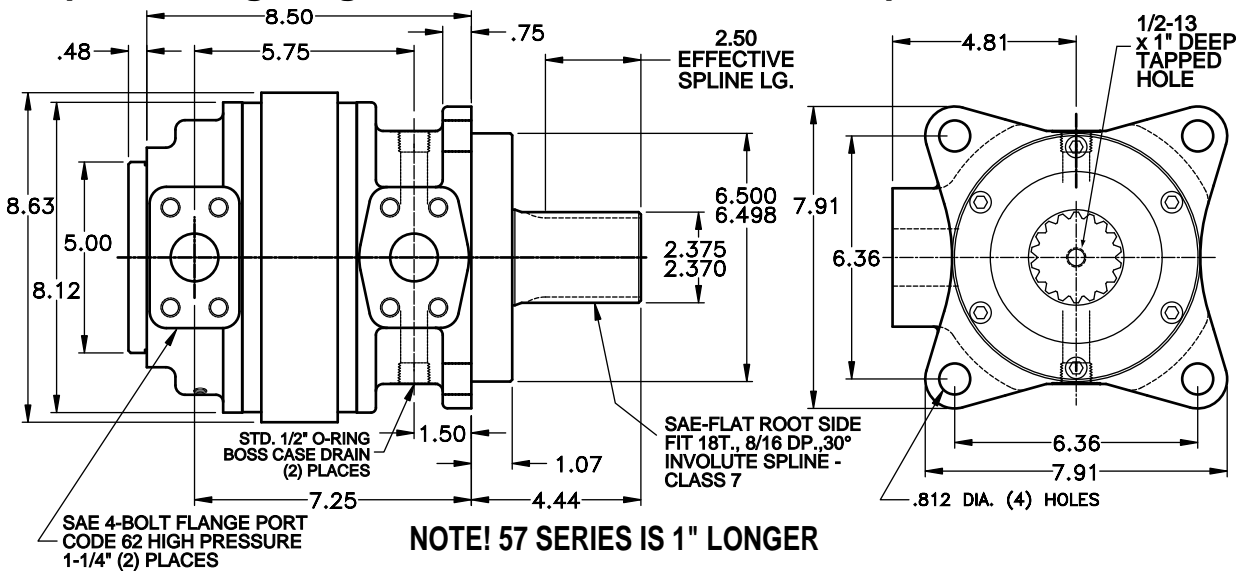

## Envelope Drawing - Double Stack High Performance Motor - All Displacements

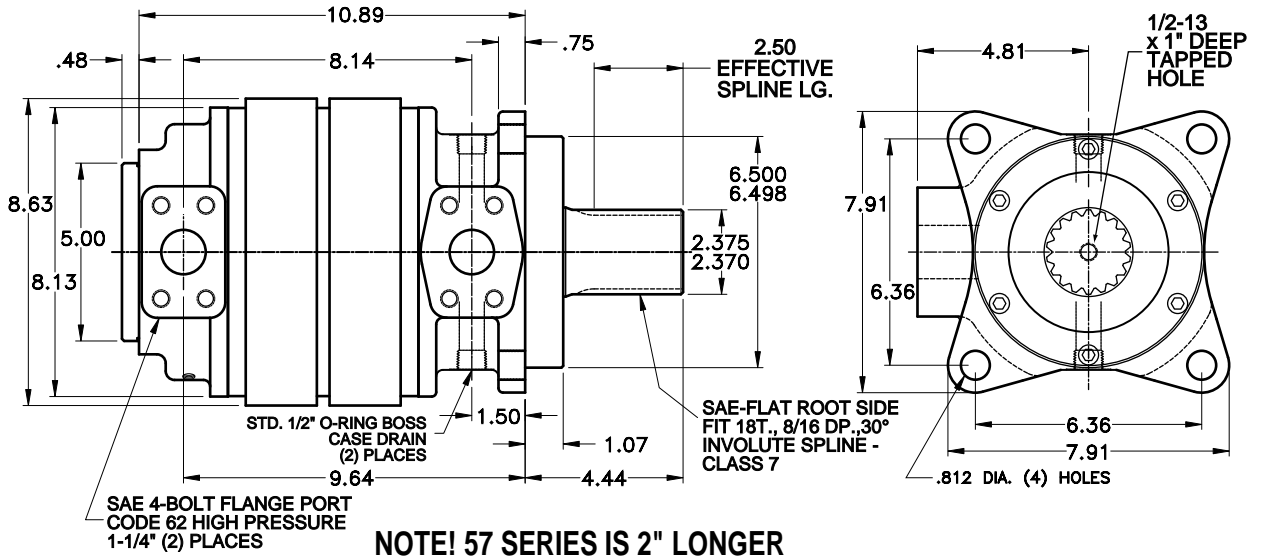

## Envelope Drawing - 4-Port High Performance Motor - All Displacements

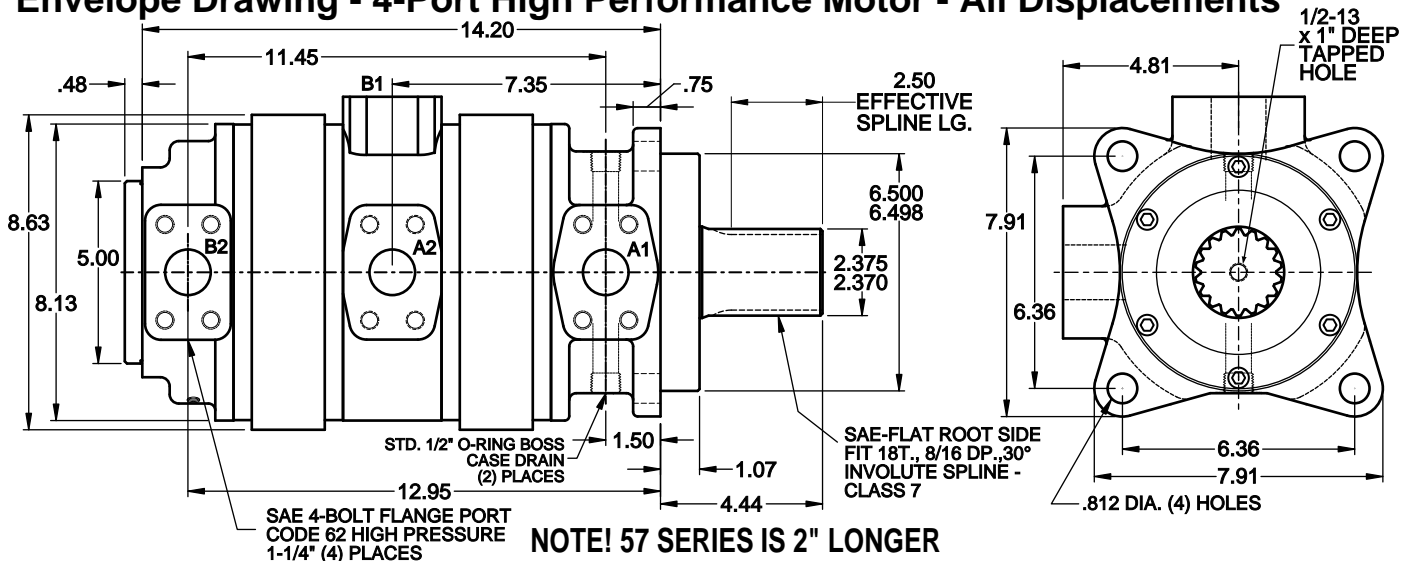

## VANE CROSSING VANE

The Rineer patented vane crossing vane design produces much higher volumetric and mechanical efficiencies than is possible with a standard vane type design. This design provides a sealing vane between cavities to improve mechanical and volumetric efficiencies.

## STARTING AND STALL TORQUE

The Rineer motor produces torque curves which are virtually flat, with starting and stall torque equal to approximately 90-94% of theoretical torque.

## MORE POWER STROKES PER REVOLUTION

The 37 Series has four stator cavities and 10 rotor vanes. Each rotor vane works in each stator cavity once per revolution, which results in 40 power strokes per revolution. This helps produce higher mechanical efficiency and flatter torque curves.

## 4-PORTED MOTOR CONFIGURATION

4-Ported motors have displacements normally ranging from 24 in<sup>3</sup> to 74 in<sup>3</sup> in the 37 series motor and 97 in<sup>3</sup> to 114 in<sup>3</sup> in the 57 series motor and are comprised of two rotor stator packages separated by a mid-inlet housing. This allows the packages to function individually or in parallel. Any of the standard displacement packages may be combined to satisfy total displacement requirements.

## HIGH PERFORMANCE MOTOR, FEMALE SHAFT

Female shaft motors are available with either female keyed or splined output. This shaft configuration allows for quick and easy installation by utilizing a torque arm mount.

## BEARING LOADING

The Timken bearings in the 37 Series High Performance Motor can accept thrust load up to 7,080 lbs. dynamic or 62,000 lbs. static. Radial loading is also permissible up to 9,840 lbs. dynamic or 50,000 lbs. static. For details, request load vs. RPM & life data. Consult with a Rineer Application Engineer for optional bearing configurations to match your application.

## SEALS

Viton shaft seals are supplied as standard on the Rineer HP series motors.

## 2S or 2L

When rotating at speeds below 500 RPM, 2L (Low Clearance) design should be used. 2S design should be used when normal speeds are above 500 RPM.

## ROTATION

The 37 Series Motor rotates equally well in either direction and smoothly throughout its entire pressure and speed range. Looking into the end of the shaft, rotation is clockwise when oil is supplied to the ports nearest the shaft output end (A1 and A2).

## HORSEPOWER LIMITATION

Maximum horsepower limitation may vary with different applications. **When using the 37-57 Series High Performance Motor above 300 HP, consult a Rineer Application Engineer.**

## FILTRATON

25 micron minimum.

## WEIGHT

The weight of the 37/57 series High Performance Motor is as follows for all displacements:

37 single stack motor = 112 lbs.    57 single stack = 127 lbs.  
37 double stk. motor = 149 lbs.    57 double stk. = 179 lbs.  
37 4-port motor = 187 lbs.        57 4-port motor = 216 lbs.

## FLUID

We suggest premium grade fluids containing high quality rust, oxidation and foam inhibitors, along with anti-wear additives. For best performance, minimum viscosity should be maintained at 150 SUS at operating temperature. Fluid temperature should not exceed 180° F. Elevated fluid temperature will adversely affect seal life while accelerating oxidation and fluid breakdown. Fire resistant fluids may be used with certain limitations. Contact Rineer for additional information.

## CASE DRAIN

The 37 Series High Performance Motor is designed for external case drain. Two case drain ports are supplied; use the port at the highest elevation. We recommend case drain pressure of 35 PSI or less when using the standard seals.

## CASE DRAIN CIRCULATION

Fluid should be circulated through the case when a temperature differential exists between the motor and the system in excess of 50° F or when motor output exceeds 150 horsepower. **Should this occur, contact a Rineer Application Engineer.**

## MOUNTING

The mounting position is unrestricted. The shafts, pilots, and mounting faces should be within .002 TIR.

## INTERMITTENT CONDITIONS

Intermittent conditions are to be less than 10% of every minute.

## TWO-SPEED OPERATION

The High Performance 4-Ported Motor can be used as a two-speed when combined with external valving. A series parallel circuit can only be used when both cartridges are of equal displacement. A circuit using two-way or logic valves can be used with equal or unequal displacement cartridges. When using the logic circuit, it should be connected to insure proper mixing of oil in the circulating cartridge. Particular attention should be given to the size and flow capacity, as this valve must handle the displacement of the circulating cartridge when in the high speed mode. For example: a 37 C.I.D. + 26 C.I.D. = 63 C.I.D. with speed ratios of 3.08:1 or 1.48:1.

## OTHER AVAILABLE MOTORS

For information on additional Rineer Motors, request one of the following publications:

15 Series .....Publication DS151001  
15 Series Two Speed Motor.....Publication DS151002  
15 Series Wheel Motor.....Publication DS151003  
37 Series .....Publication DS371003  
57 Series .....Publication DS571003  
125 Series .....Publication DS1251003

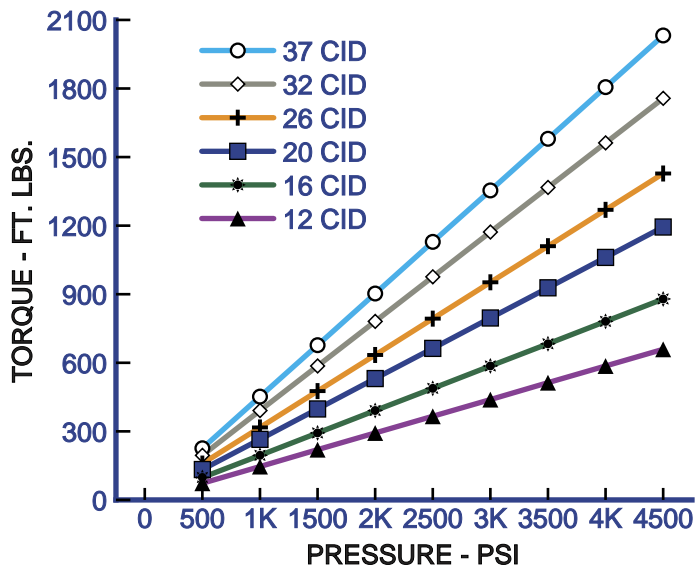
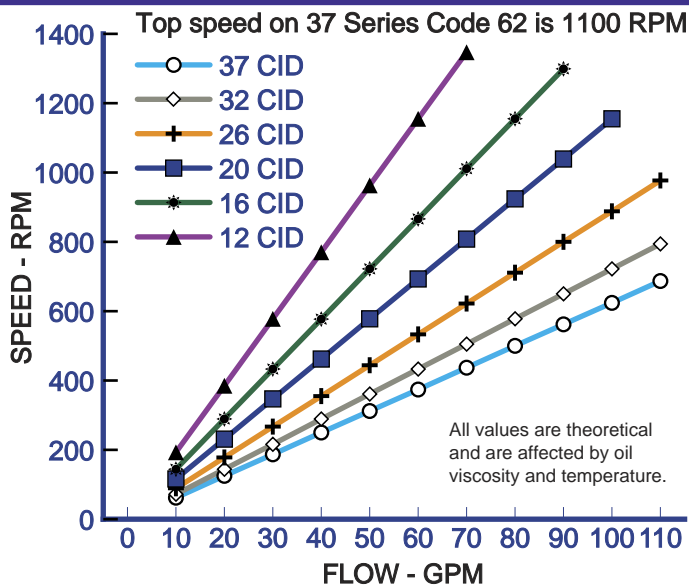

## Model Code

**37D2 / 37D4**

37D2 = 37 C62  
 37D4 = 37 4-Port C62

2S = C62 Std.  
 2L = C62 Low Speed  
 2H = C62 High Speed

**57D2 / 57D4**

57D2 = 57 C62  
 57D4 = 57 4-Port C62

**-2S**

**-037**

**-31**

**-T1**

**-DVD**

Seal Package Selection

31 = Splined Shaft  
 40 = Double Splined

Single Stacked

Double Stacked  
 or 4-port

012 = 12 in <sup>3</sup> (197cc)/rev.	024 = 24 in <sup>3</sup> (393cc)/rev.
016 = 16 in <sup>3</sup> (262cc)/rev.	028 = 28 in <sup>3</sup> (459cc)/rev.
020 = 20 in <sup>3</sup> (328cc)/rev.	032 = 32 in <sup>3</sup> (525cc)/rev.
026 = 26 in <sup>3</sup> (426cc)/rev.	036 = 36 in <sup>3</sup> (590cc)/rev.
032 = 32 in <sup>3</sup> (524cc)/rev.	040 = 40 in <sup>3</sup> (656cc)/rev.
037 = 37 in <sup>3</sup> (606cc)/rev.	046 = 46 in <sup>3</sup> (754cc)/rev.
	052 = 52 in <sup>3</sup> (852cc)/rev.
	064 = 64 in <sup>3</sup> (1049cc)/rev.
	074 = 74 in <sup>3</sup> (1213cc)/rev.

**57**

**37**

048 = 48 in <sup>3</sup> (787cc)/rev.	096 = 96 in <sup>3</sup> (1573cc)/rev.
055 = 55.5 in <sup>3</sup> (910cc)/rev.	103 = 103 in <sup>3</sup> (1688cc)/rev.
	111 = 111 in <sup>3</sup> (1819cc)/rev.

Bearing Package Selection

## Envelope - 57/37 4-Port

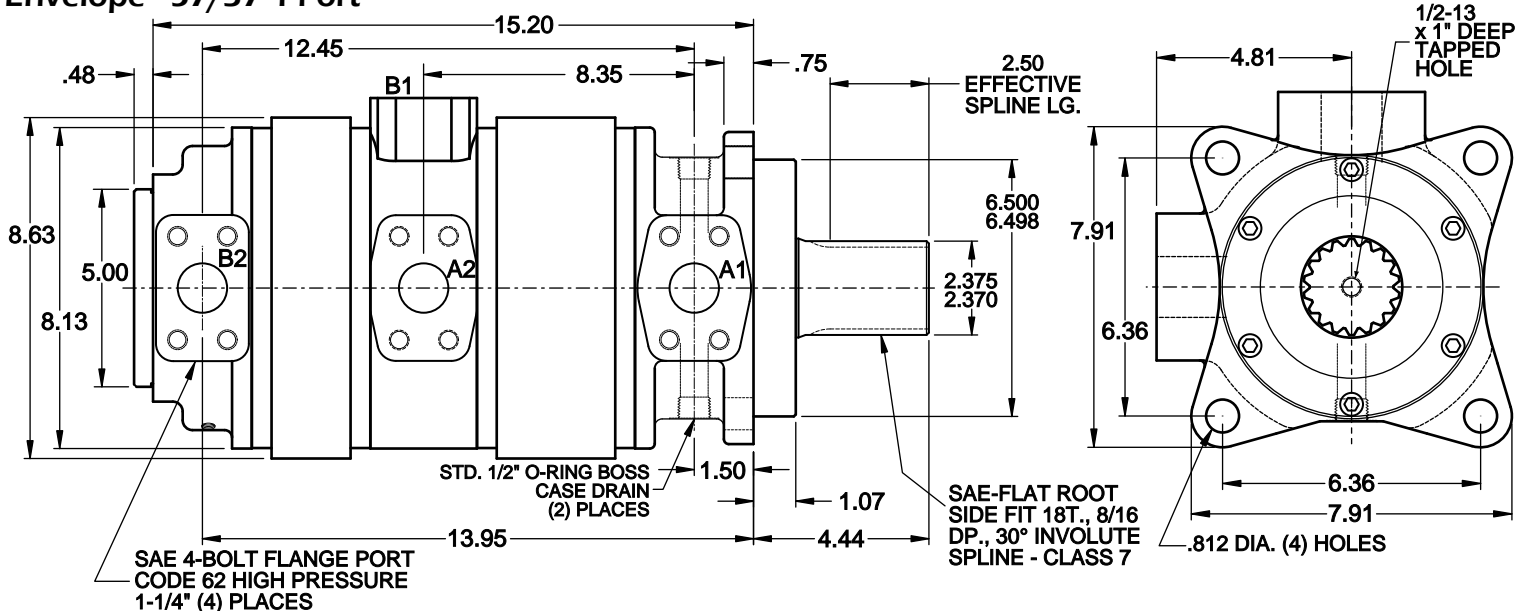

# RINEER HYDRAULICS, INC.

331 Breesport San Antonio, Texas 78216 (210)341-6333 Fax: (210)341-1231

Website: [www.rineer.com](http://www.rineer.com) E-mail: [sales@rineer.com](mailto:sales@rineer.com)